

Spicer® Steer Axles



SPICER®

Drivetrain Products

Service Manual

AXSM-0070

November 2017

Front Drive Steer Axle
Model 60

General Information

The description and specifications contained in this service publication are current at the time of printing. Dana reserves the right to discontinue or to modify its models and/or procedures and to change specifications at any time without notice.

Any reference to brand names in this publication is made simply as an example of the types of tools and materials recommended for use and should not be considered an endorsement. Equivalents, if available, may be used.

Important Notice

This symbol is used throughout this manual to call attention to procedures where carelessness or failure to follow specific instructions may result in personal injury and/or component damage.

Departure from the instructions, choice of tools, materials and recommended parts mentioned in this publication may jeopardize the personal safety of the service technician or vehicle operator.

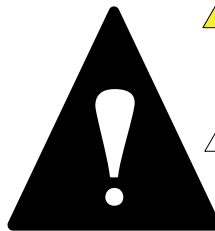

 **WARNING:** Failure to follow indicated procedures creates a high risk of personal injury to the servicing technician.

 **CAUTION:** Failure to follow indicated procedures may cause component damage or malfunction.

 **IMPORTANT:** Highly recommended procedures for proper service of this unit.

Note: Additional service information not covered in the service procedures.

TIP: Helpful removal and installation procedures to aid in the service of this unit.

[Always use genuine Spicer replacement parts.](#)

Note: Interactive PDF functions may not work correctly unless viewed using the free [Adobe Acrobat Reader](#).

Table of Contents

General Information

Axle Identification	1
Gear Ratio	1

Front Axle

Drive Steer Wheel End and Brake Disassembly	2
Drive Steer Wheel End and Brake Assembly	4

Carrier

Carrier Disassembly	8
Carrier Assembly	12
View of Ring and Pinion Set	14
Assembly of Differential	20
Service Tools List	23

Axle Identification

All Spicer axles are identified with a manufacturing date and the complete part number stamped in the right hand tube. Also each axle contains a gear ratio tag, and if the axle is equipped with a limited slip differential, it will contain a tag specifying the use of limited slip lubricant.

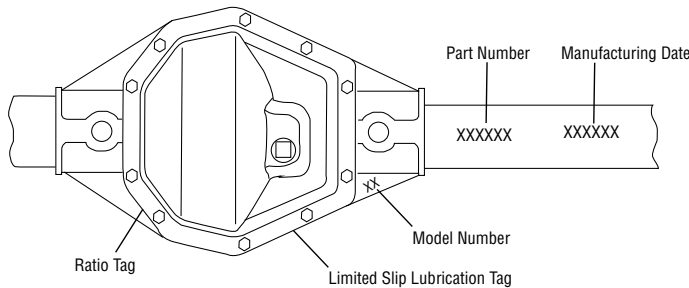

Figure 1

In this figure the axle is identified with 1/8" (3.17 mm) high numbers stamped in the tube. For Example: The manufacturing date or build date of the axle is interpreted as follows. 'the first number is the month, second number is the day of the month, the third number is the year. the letter is the shift, and the last number is the line that built the axle. The next number is the part (bill of material) number. 'the six digits reading from left to right is the basic number for identifying the particular axle assembly. The seventh digit following the dash will identify ratio, differential and end yoke options used in the assembly.

Note: In the event there are two build dates, the latter will be the date in which the brake components were assembled. The number stamped next to the manufacturing date is the complete axle assembly part number. It is recommended that when referring to the axle, obtain the complete part number and build date. To do this, it may be necessary to wipe or scrape off the dirt etc., from the tube.

Note: On front driving axles, the above numbers can be either on the long or short tube.

Gear Ratio

The gear ratio tag is located on the left side of the cover plate/ or at the bottom left hand side of the cover plate, and is held in place with one or two cover plate screws. This tag gives the tooth combination of the ring and pinion, and also the total gear ratio.

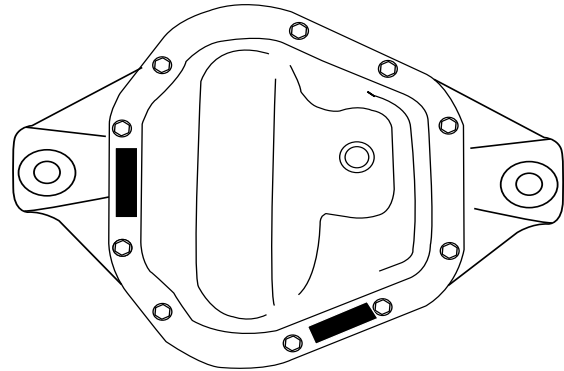
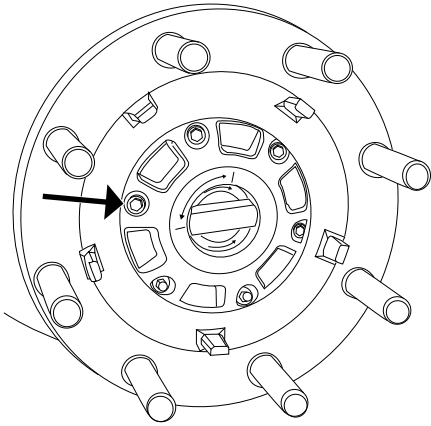

Figure 2

Drive Steer Wheel End and Brake Disassembly

1. Remove the six fasteners from the wheel lock. Now remove the lock out assembly.



2. Remove the six bolts from the caliper assembly. Remove the caliper.

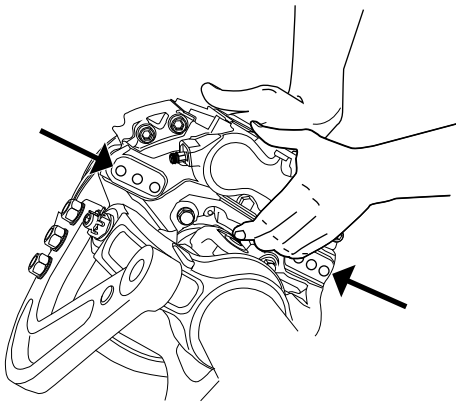

3. Use a breaker bar and socket to loosen then remove the spindle nut.

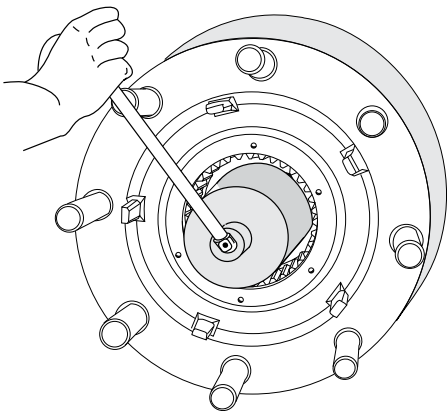

4. Support the hub assembly before you remove the hub from the spindle. Remove hub assembly.

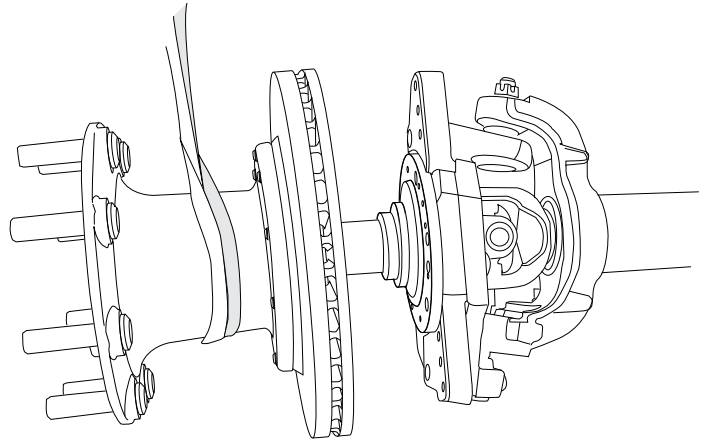

5. Remove the two fasteners from the ABS sensor bracket. Remove the sensor.

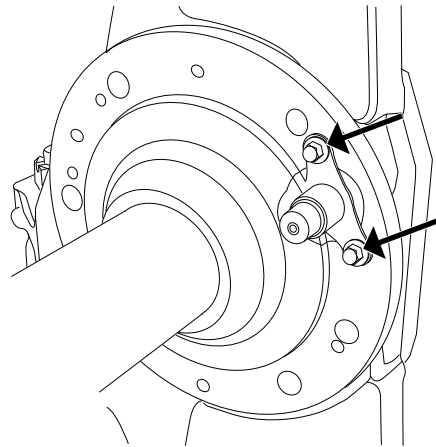

6. Remove the axle shaft snap ring and thrust washer.

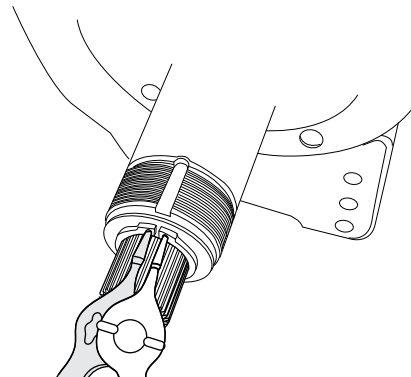

7. Remove the spindle flange bolts.

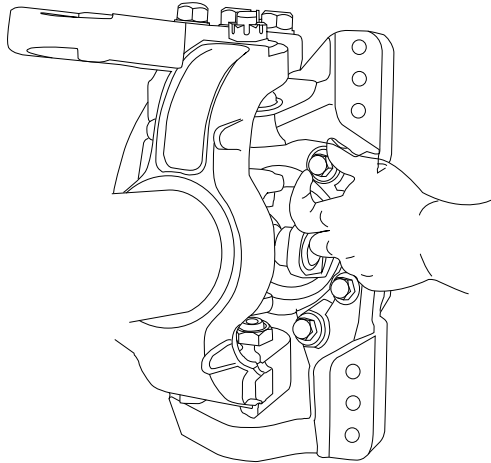

8. Now remove the spindle. Use a dead blow hammer to loosen the spindle from the knuckle assembly.

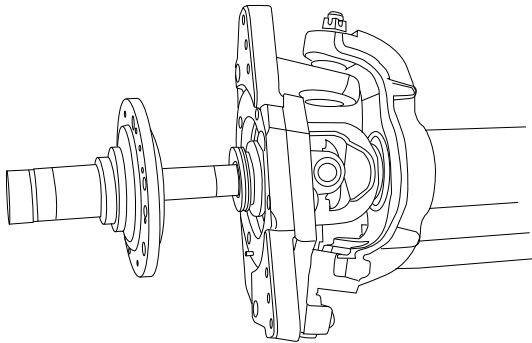

9. The axle shaft assembly can now be removed. Again, a dead blow hammer can be used to get the shaft started.

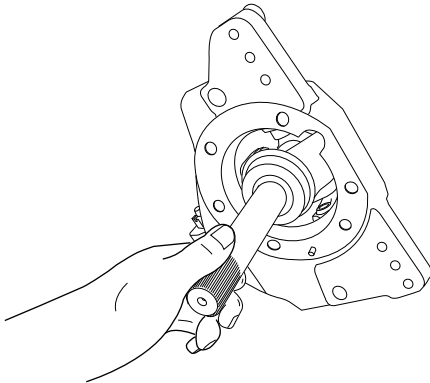

10. Disconnect the tie rod end from the knuckle assembly.

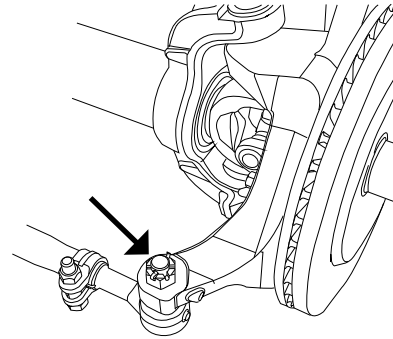

11. The knuckle assembly can now be disassembled. First remove the cotter pins from the top and bottom ball joints. Loosen the nuts so they are flush with the top of the stud.

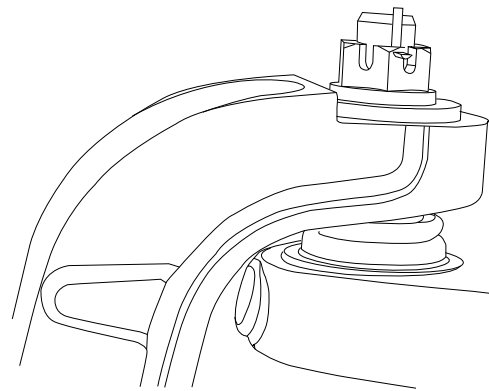

12. Use a small steel mallet to unseat the upper and lower ball studs. Remove the nuts and the knuckle assembly.

13. Using a press and adapter remove the ball studs.

Drive Steer Wheel End and Brake Assembly

1. Install the axle shaft assemble by rotating the shaft to align the splines.

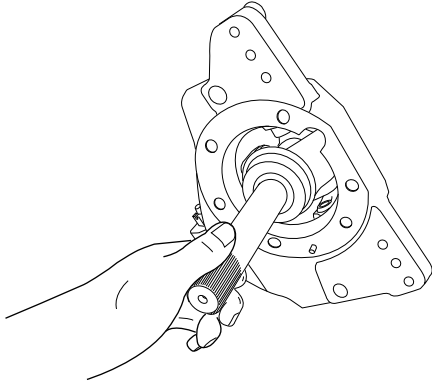

2. With a dead blow hammer, make sure the shaft seal is fully seated.

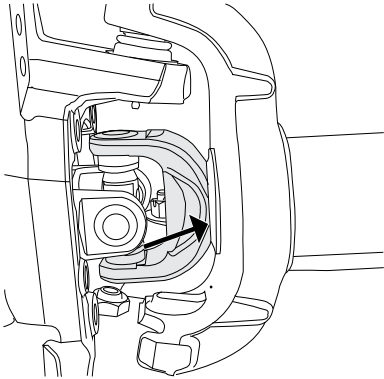

3. The spindle can now be installed. Slide the spindle over the axle shaft and align the bolt holes.

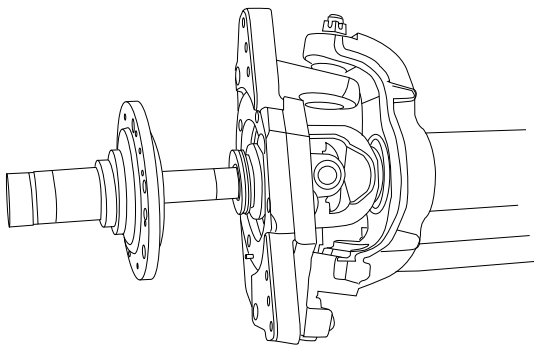

4. Install the spindle fasteners and torque to 118 – 131 ft. lbs. (160-178 N•m).

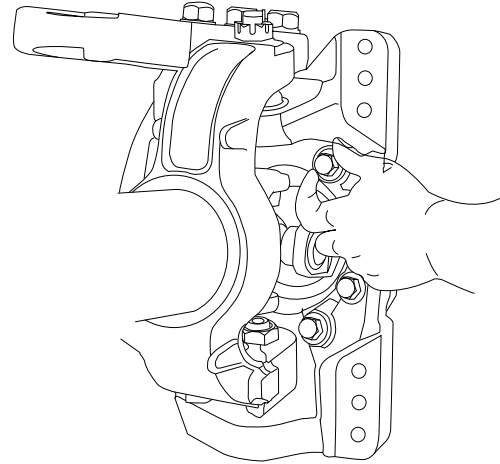

5. Install the thrust washer.

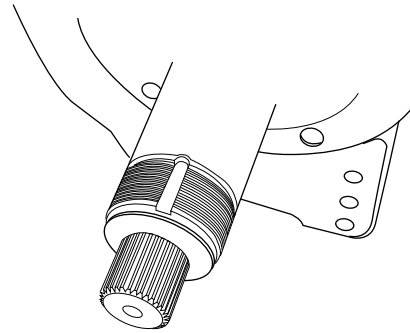

6. The axle shaft snap ring can now be installed.

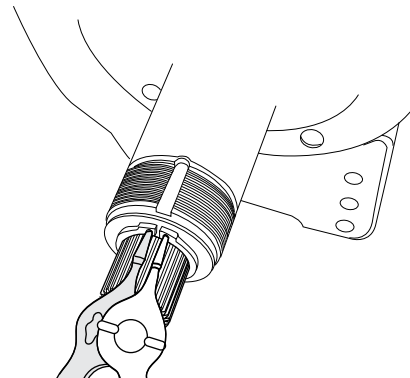

7. Install the ABS sensor, bracket and bolts. Torque the fastener to 7-9 ft. lbs. (9-12 N•m).

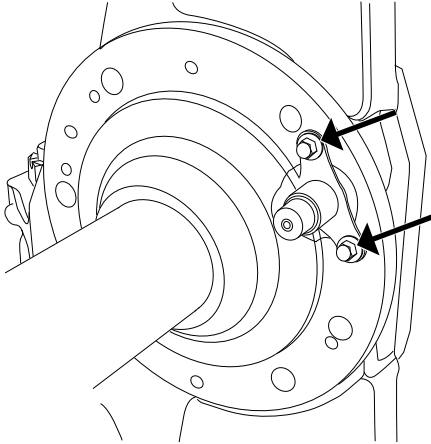

8. The hub and rotor can now be assembled. Place the hub assembly in a press if available.

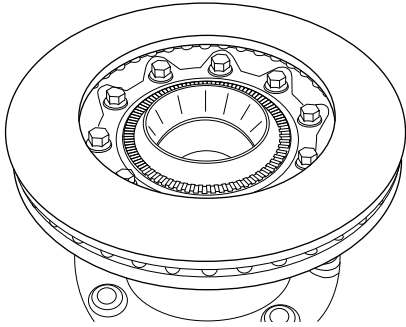

9. The first step is to grease pack the inner wheel bearing and install to the hub.

10. Install the wheel seal. Use a seal driver that will not damage the seal during installation.

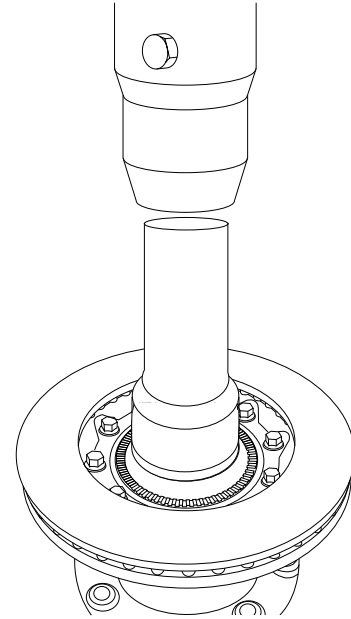

11. Apply a thin coat of grease to the bearing journals of the spindle.

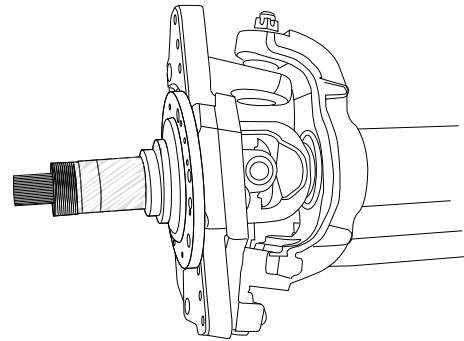

12. The hub and rotor assembly can now be installed. It's important to not damage the wheel seal during installation. Use an overhead hoist if available.

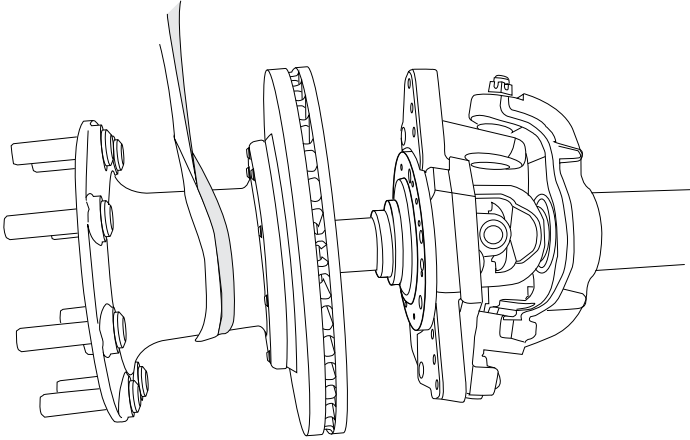

13. While supporting the wheel assembly, install the outer wheel bearing.

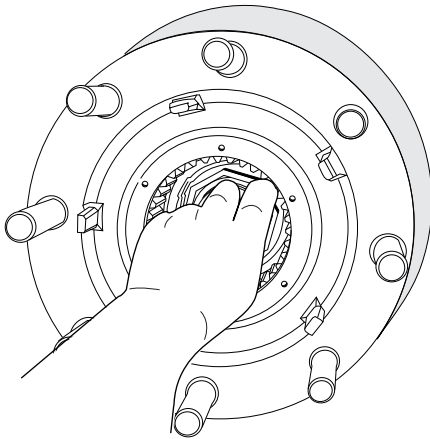

14. Install the spindle nut. Always start the nut by hand.

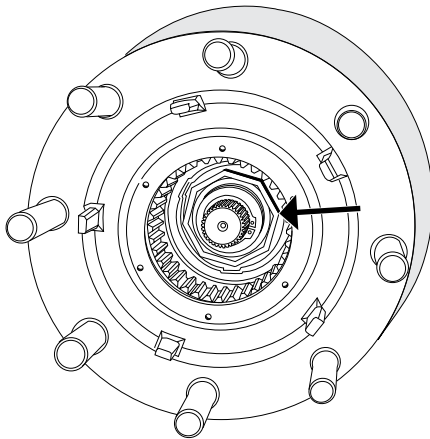

15. While rotating the wheel, tighten the spindle nut to 65 ft. lbs. (88 N•m)

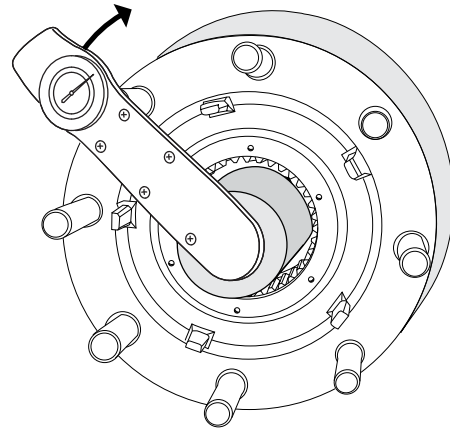

16. Now back off the nut 1/4 turn. Again, while rotating the wheel torque the spindle nut to 20 ft. lbs. (27 N•m)

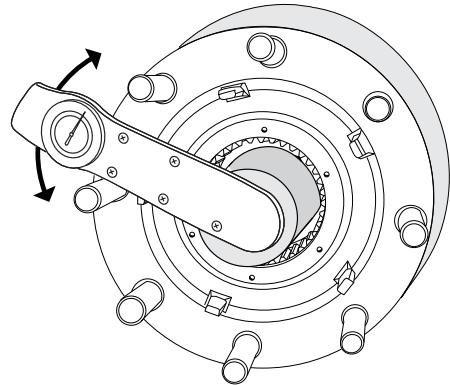

17. Install the wheel lock out assembly and fasteners. Torque fasteners to 6-9 ft. lbs. (8-11 N•m).

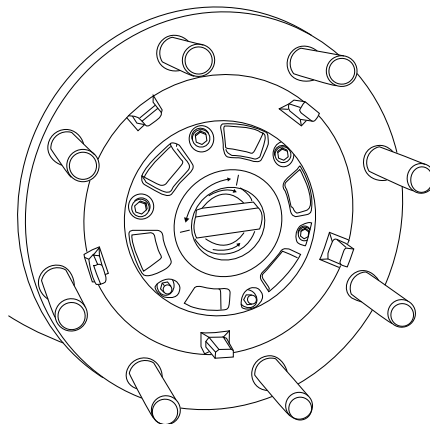

- 18.** With the wheel assembly installed we can assembly the brake pads to the caliper. Install both pads with the brackets facing the caliper pistons. Install the brake pad retainer and fastener. Torque to 25-30 ft. lbs. (34-40 N•m)

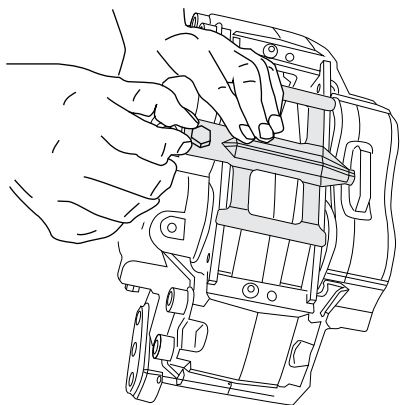

- 19.** Install the caliper assembly so that the bleed screw is facing the top of the axle.

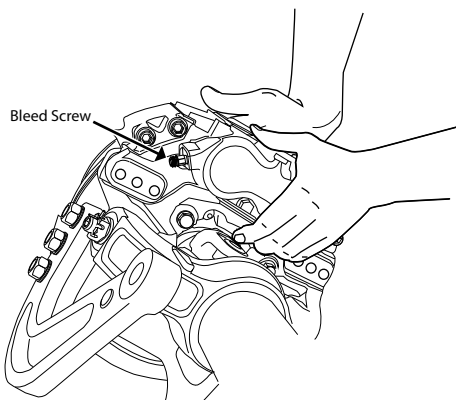

- 20.** Install the six bolts that mount the caliper to the steer knuckle. Torque to 125-140 ft. lbs. (169-190 N•m).

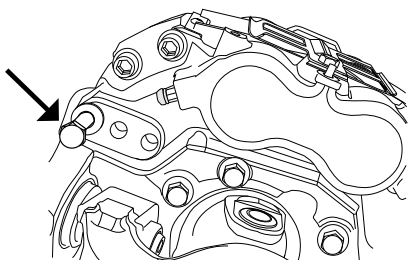

Carrier Disassembly

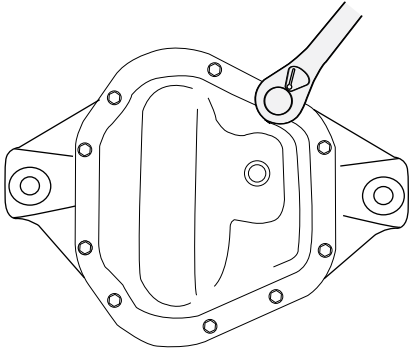
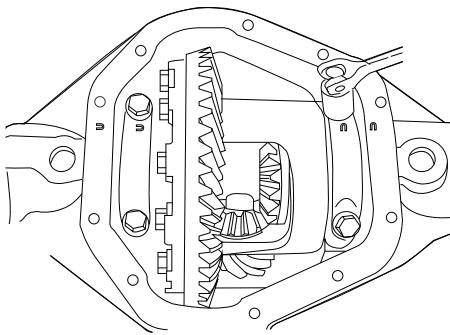

Figure 21

1. To drain the axle lubricant, remove the cover plate fasteners and remove the cover. Remove cover plate screws, cover plate, and cover plate gasket. Discard old gasket. Tip carrier to allow lube to drain completely. Also during this time clean the cover face of the carrier, making sure it is free from any nicks and any particles left by the old gasket. Do not use cleaning solvents of any type. Use of cleaning solvents may prevent the “RTV” sealant from adhering to the cover plate and carrier, resulting in leaks of lubricant.

CAUTION: Before removing differential case and ring gear, make sure the axle shafts are pulled out far enough for clearance to remove differential. Refer to section of manual covering the type of axle assembly being serviced for procedures on removing the axle shafts.



2. Remove bearing caps.

IMPORTANT: Mating letters stamped on caps and carrier. This is important at time of assembly as they are to be assembled exactly as removed. Letter or numbers are in vertical and horizontal position.

Note: After removing axle shafts from the rear axle, semi-float shaft riding bearing unit, assemble pinion mate shaft and lock pin (finger tight only) into the differential case. This procedure is necessary to prevent the cross shaft from dropping out and the differential side gears and differential pinion mate gears from retaining in the case and dropping out when servicing the carrier section.

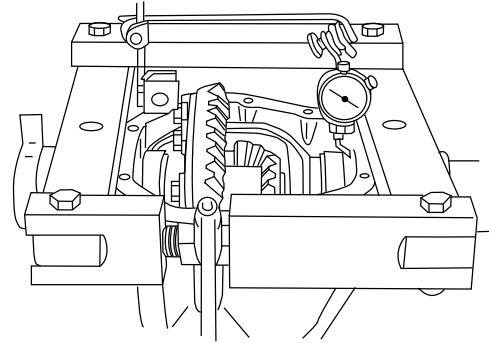

3. Mount spreader to housing. Do not spread carrier over .015 in. (.38 mm). Use dial indicator as shown.

Note: This spreader can also be used on the Spicer Model 44 axle.

TOOL:

D-167	Spreader
D-128	Indicator Set

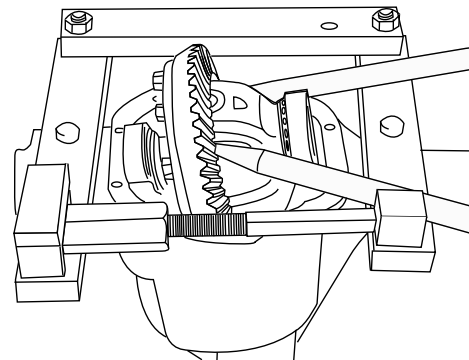

4. Pry differential case from carrier with two pry bars as shown. After differential case has been removed, remove spreader. Use caution to avoid damage to ring and pinion. Mark or tag bearing cups indicating from which side they were removed.

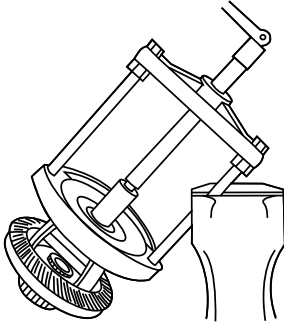

5. Remove differential bearing cups with a puller as shown. Wire shims, bearing cup and bearing cone together. Identify from which side they were removed (ring gear side or opposite side). If shims are mutilated, replace with new ones at time of assembly. Shims are available in thicknesses of .003, .005, .010, and .030 in. (.08, .13, .25, and .76 mm). Reposition case in puller and remove other bearing cone as described above.

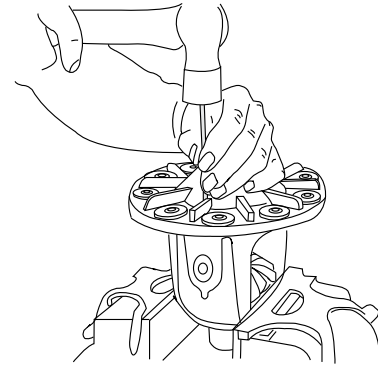

7. Replace case in vice and drive out lock pin which secures the pinion mate shaft. Use a small drift as shown.

Note: The semi-float shaft siding bearing design has a lock pin that is removed with a wrench. The pinion mate shaft is of the slip fit design and can be removed by hand.

TOOL:

DD-914P	Press
DD-914-62	Adapter
DD-914-8 or 9	Adapter ring
DD-914-7	Extension
DD-914-42	Button

Note: It is recommended that whenever bearings are removed, they are (irregardless of mileage) to be replaced with new ones.

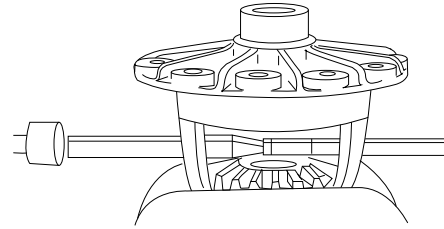

8. Remove pinion mate shaft with drift as shown.

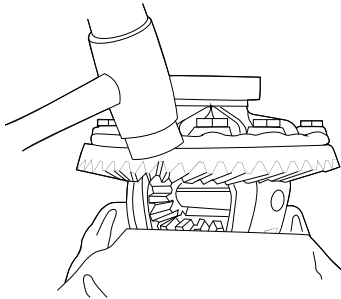

6. Place a few shop towels over the vice to prevent the ring teeth from being nicked after it is free from the case. Place case in vice. Remove ring gear screws. Tap ring gear with a rawhide hammer to free it from the case. Remove case and ring gear from vice.

Note: It is recommended that whenever the ring gear screws are removed they are replaced with new ones.

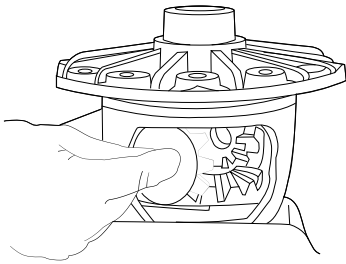

9. To remove side gears and pinion mate gears, rotate the side gears. This will allow the pinion mate gears to turn to the opening of the case. Remove pinion mate gears and also the spherical washers behind the gears. Lift out side gears and thrust washers. Inspect all parts, including the machined surfaces of the case itself. If excessive wear is visible on all parts, it is suggested that the complete differential assembly be replaced. If any one of the gears are to be replaced, THEY ARE TO BE REPLACED AS A SET.

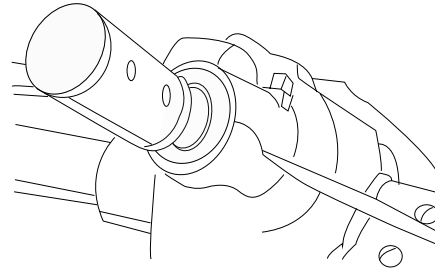

12. Remove pinion by tapping with a rawhide hammer. Catch the pinion with your hand to prevent it from falling to the ground and being damaged.

Note: On the spline end of the pinion there are bearing preload shims. These shims may stick to the pinion or bearing or even fall out. These shims are to be collected and kept together since they will be used later during assembly. Try not to mutilate shims. If shims are mutilated, replace with new ones. Shims are available in thicknesses of .003", .005", .101", and .030" (.08, .13, .25, and .76 mm).

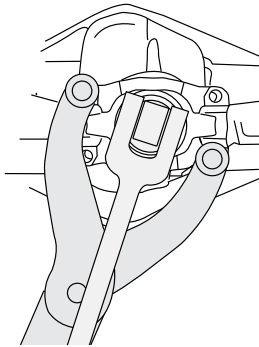

10. Turn nose of carrier in a horizontal position and remove the pinion nut. Hold end yoke or flange with tool as shown, then remove pinion nut and washer.

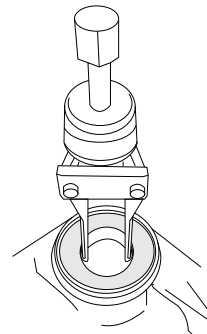

13. Pull out pinion seal with puller as shown. Discard seal. Replace with a new one at time of assembly. Remove bearing cone and outer oil slinger.

TOOL:

D-131	Slide Hammer
-------	--------------

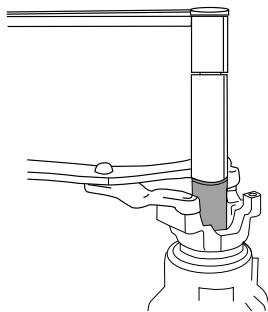

11. Remove end yoke or flange with tools as shown. If end yoke or flange show wear in the area of seal contact, it should be replaced.

TOOL:

C-3281	Holding Wrench
C-452	Yoke Remover

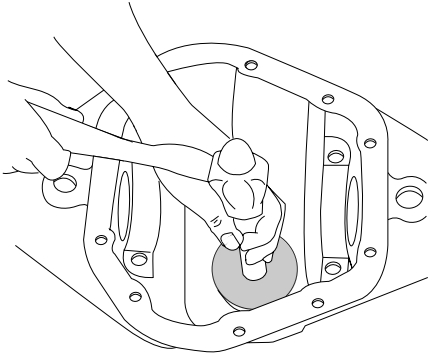

14. Turn nose of carrier down. Remove outer pinion bearing cup. Locate driver on back edge of cup and drive cup out of carrier.

CAUTION: Do not nick carrier bore.

TOOL:

D-158	Cup Remover
C-4171	Handle

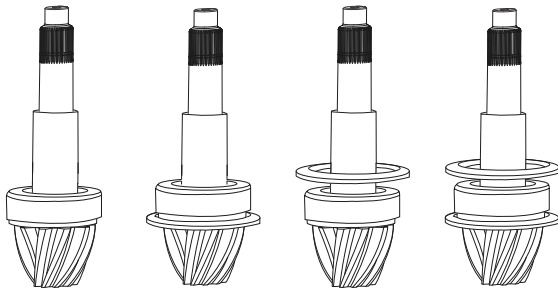

Note: The front end carrier section may vary in pinion horn depth due to the possibility of the need for either a baffle or slinger or both.

The baffle serves the purpose of assisting the lube to flow up through the oil channels to lubricate the pinion bearings. If used, they are part of the pinion setting adjustment. The four different options are shown.

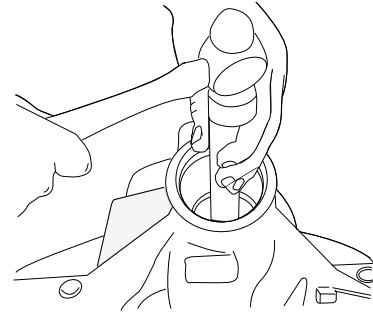

15. Remove the inner bearing cup with tools as shown.

TOOL:

C-4171	Handle
D-162	Cup Remover

Note: Shims are located between the bearing cup and carrier bore and may also include an oil baffle. If shims and baffle are bent or nicked, they should be replaced at time of assembly. Wire and stack together and measure each. If stack has to be replaced, replace with same thickness.

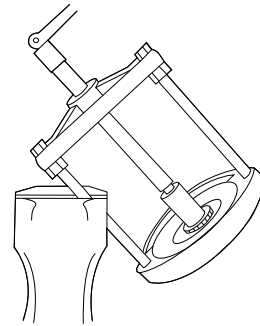

16. Remove pinion bearing with tools as shown.

TOOL:

EE914-P	Press
DD-914-9	Adapter Ring
C-293-37	Adapters

Note: Both baffle and slinger are part of the pinion adjustment shims and are to be kept intact for assembly.

Carrier Assembly

1. On all front driving axles there are axle shaft oil seals pressed into the tube ends of the carrier.

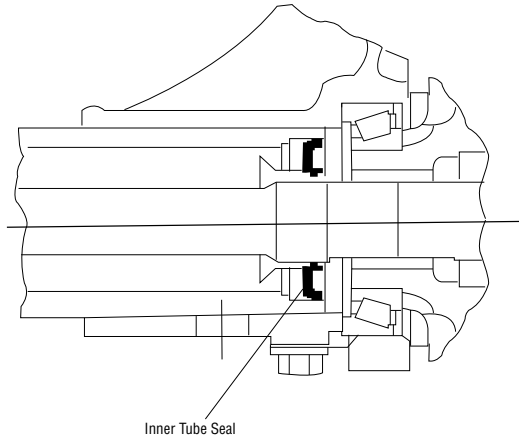

2. This design consists of the integral seal (unit) whereby the seal and guide are combined (one for each side).

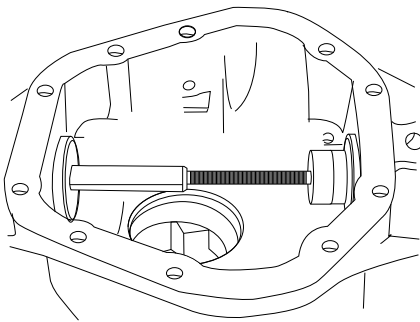

3. Assemble inner axle shaft seals and guides using tools as shown.

TOOL:

D-195	Installer
-------	-----------

When assembling the seals, make sure they are positioned straight and don't get cocked. Turn forcing screw until it stops: seals will then be positioned. Grease lips of seals.

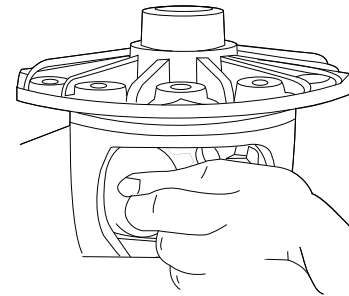

4. Place differential case in vise as shown. Apply grease to new side gear thrust washers and to hubs and thrust face of the new side gears. Assemble both side gears. Apply grease to the new spherical washers and the new pinion male gears. Assemble new pinion male gears and washers.

An easy way to assemble the side gears and pinion male gears is to have all parts lubricated before assembly.

5. Assemble both side gears and thrust washers. Hold them in place with hand, then assemble the pinion male gears and washers to hold the side gears in place.
6. Rotate the side gears until the holes of the washers and pinion gears line up with the holes of the case. If the gears cannot be rotated by hand, install one of the axle shafts into the side gear spline and use a pipe wrench to turn the shaft.

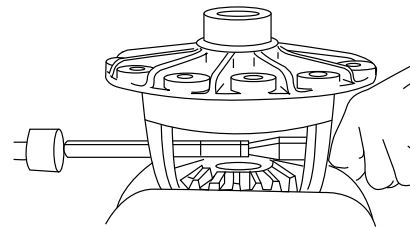

7. Use a drift to line up the holes with those of the differential case. Assemble pinion male shaft. Drive on shaft to remove drift. Make sure lock pin hole of the shaft is lined up with the lock pin hole of the case.

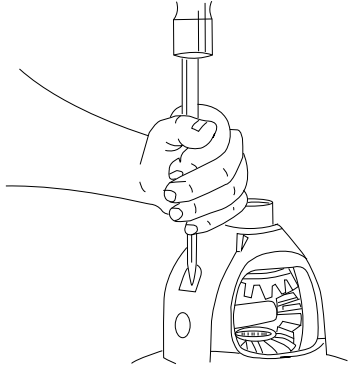

8. The semi-float shaft riding bearing design uses a lock pin that is assembled with the use of a wrench. Use lock pin and assemble finger tight only. This procedure is necessary to prevent differential side gears from rotating in the case and dropping out when servicing the carrier section. A new lock pin will be installed after assembling the axle shafts.

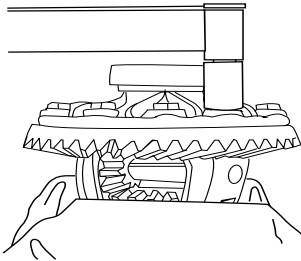

9. Make sure flange face of the case is free of nicks or burrs. Assemble ring gear to case. Line up holes of the ring gear with those of the case. Use new ring gear screws. Draw up screws alternately and evenly. Torque ring gear screws to 100-120 lbs. ft. (136-163 N•m).

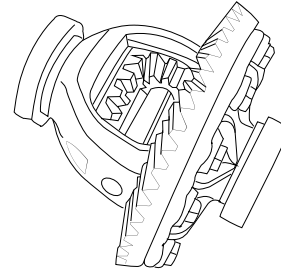

10. Install master differential bearings onto case. Remove all nicks, burrs, dirt, etc. from hub to allow master bearings to rotate freely.

TOOL:

D-117	Master Differential Gearings
-------	------------------------------

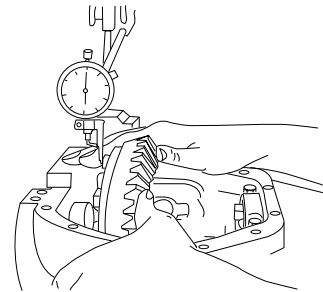

11. Assemble differential case into carrier (less pinion). Mount dial indicator with a magnetic base as shown. Locate tip of indicator on flat surface of one of the ring gear screw spline faces. Mark location with a piece of chalk. Force differential assembly as far as possible in the direction towards the indicator. With force still applied, set indicator at zero (0).

TOOL:

D-128	Indicator Set
-------	---------------

- Note:** Dial indicator should have a minimum travel of .200" (15.08 mm).

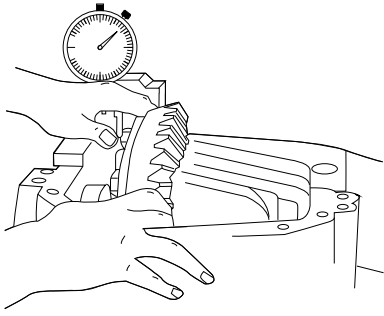

12. Force the differential assembly as far as it will go in the opposite direction. Repeat this step until you have obtained the same reading. Record the reading of the indicator. This will be the total amount of shims required (load preload) and will be calculated later during assembly. After making sure the readings are correct, remove indicator and differential assembly from housing.

! IMPORTANT: Do not remove master bearings from differential case at this time.

View of Ring and Pinion Set

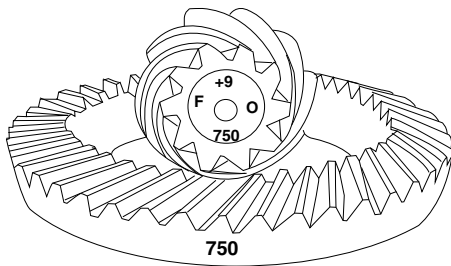

Ring gears and pinions are supplied in matched sets only. Matching numbers on both the pinion and the ring gear are etched for verification. If a new gear set is being used, verify the numbers of each pinion and ring gear before proceeding with assembly.

The nominal distance from the centerline of the ring gear to the end of the pinion for the Model 60 (front end rear axle is 3.125 in. (79.27 mm). On the button end of each pinion there is etched a (+) number, a minus (-) number, or a zero (0) number which indicates the bearing running position for each particular gear set. This dimension is controlled by the shimming behind the inner pinion bearing cup.

For example, if a pinion is etched with a plus +3 (m+8), this pinion would require .003 in. (.08 mm) less shims than a pinion etched "0". This means by removing shims, the mounting distance of the pinion is increased to 3.128 in. (79.45 mm), which is just what a +3 (m+8) indicates. Or if a pinion is etched -3 (m-8), we would want to add .003 in. (.08 mm) shims than would be required if the pinion was etched "0". By adding .003 in. (.08 mm) shims, the mounting distance of the pinion was decreased to 3.128 in. (79.39 mm) which is just what a -3 (m-8) indicated.

If the old ring and pinion set is to be reused, measure the old shim pack and build a new shim pack to this same dimension. If a baffle is used in the axle assembly, it is considered as part of the shim pack. To change the pinion adjustments, shims are available in thicknesses of .003, .005, and .010 in. (.08, .13, and .25 mm).

Note: If baffle or slinger is bent or mutilated, it should be replaced.

Measure each shim separately with a micrometer and add together to get total shim pack thickness from the original build up. If a new gear set is being used, notice the (+) or (-) etching on both the old and new pinion and adjust thickness of the new shim pack to compensate for the difference of these two figures. For example, if the old pinion reads (+) 2 (m+6) and the new pinion is (-) 2 (m-5), add .004 in. (.10 mm) shims to the original shim pack. The above procedures also apply to pinion adjustment on the front axle which includes the oil slinger between the inner bearing cone and pinion and baffle between the inner bearing cup and carrier.

Old Pinion Marking	New Pinion Marking								
	-4	-3	-2	-1	0	+1	+2	+3	+4
+4	+0.008	+0.007	+0.006	+0.005	+0.004	+0.003	+0.002	+0.001	0
+3	+0.007	+0.006	+0.005	+0.004	+0.003	+0.002	+0.001	0	-0.001
+2	+0.006	+0.005	+0.004	+0.003	+0.002	+0.001	0	-0.001	-0.002
+1	+0.005	+0.004	+0.003	+0.002	+0.001	0	-0.001	-0.002	-0.003
0	+0.004	+0.003	+0.002	+0.001	0	-0.001	-0.002	-0.003	-0.004
-1	+0.003	+0.002	+0.001	0	-0.001	-0.002	-0.003	-0.004	-0.005
-2	+0.002	+0.001	0	-0.001	-0.002	-0.003	-0.004	-0.005	-0.006
-3	+0.001	0	-0.001	-0.002	-0.003	-0.004	-0.005	-0.006	-0.007
-4	0	-0.001	-0.002	-0.003	-0.004	-0.005	-0.006	-0.007	-0.008

Pinion Setting Chart (English U.S. Standard)

Old Pinion Marking	New Pinion Marking								
	-10	-8	-5	-3	0	+3	+5	+8	+10
+10	+.20	+.18	+.15	+.13	+.10	+.08	+.05	+.03	0
+8	+.18	+.15	+.13	+.10	+.08	+.05	+.03	0	-.03
+5	+.15	+.13	+.10	+.08	+.05	+.03	0	-.03	-.05
+3	+.13	+.10	+.08	+.05	+.03	0	-.03	-.05	-.08
0	+.10	+.08	+.05	+.03	0	-.03	-.05	-.08	-.10
-3	+.08	+.05	+.03	0	-.03	-.05	-.08	-.10	-.13
-5	+.05	+.03	0	-.03	-.05	-.08	-.10	-.13	-.15
-5	+.03	0	-.03	-.05	-.08	-.10	-.13	-.15	-.18
-10	0	-.03	-.05	-.08	-.10	-.13	-.15	-.18	-.20

Pinion Setting Chart Metric

If metric used pinion will be etched Exp. (m+6). Use these charts as a guideline to set pinion.

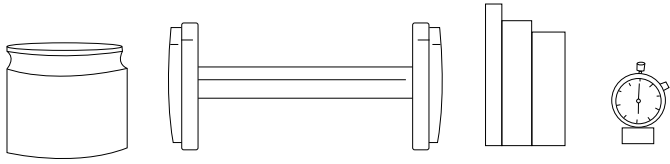

13. View of master pinion block, pinion height block, scooter gauge, cross pin, and master bearing discs.

Note: Cross arbor, master bearing discs, and scooter gauge can be used on both Model 60 and Model 70 axles.

Make sure that all carrier bores are free from all nicks, dirt, or any other contamination.

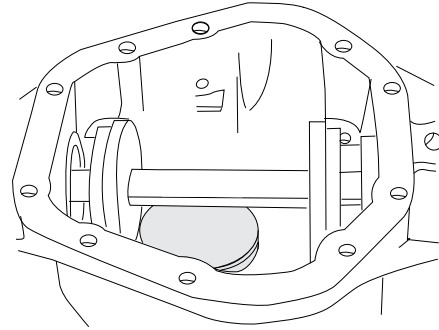

15. Place arbor discs (small diameters) and arbor into cross bores of carrier as shown.

TOOL:

D-116-2	Master Disc
D-115-3	Arbor

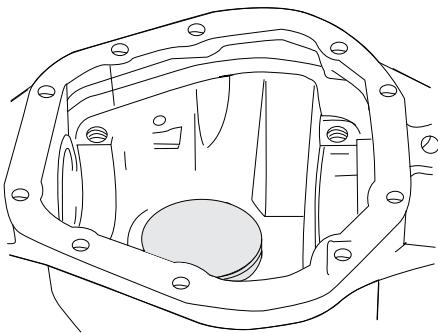

14. Place master pinion block into the pinion bore of the carrier as shown.

TOOL:

D-120	Master Pinion Block
-------	---------------------

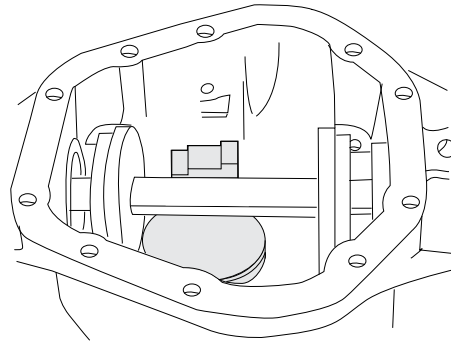

16. Place pinion height block on top of master pinion block and against arbors as shown.

TOOL:

D-116-1	Pinion Block Height Block
---------	---------------------------

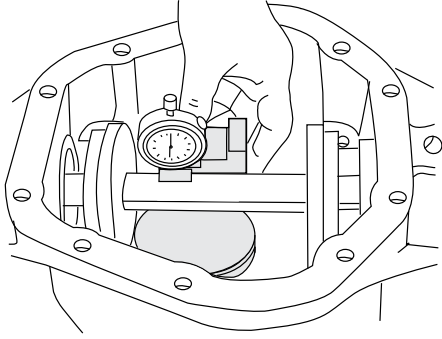

17. Place scooter gauge on small step of pinion height block. Apply pressure with fingers, making sure the gauge is flat on the pinion block. While pressure is applied set indicator at zero "0".

TOOL:

D-115	Scooter Gauge
-------	---------------

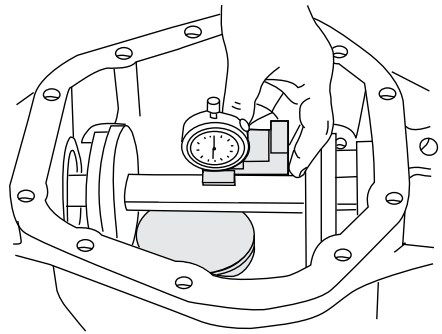

18. Slide scooter gauge over arbor. As gauge slides over top of arbor it will travel in a clockwise direction. When indicator is on center of arbor (on top) it will stop traveling in a clockwise direction. If indicator starts to travel in a counter-clockwise direction, this means you have passed the center (top) of arbor. Record only the reading when the indicator is set at the highest point.

This reading indicates the amount of shims necessary to obtain the shim pack, plus (+) or minus (-) the etching on the bottom end of the pinion.

If the etching is zero (0), the shim pack will remain unchanged.

For example: If the pinion is etched +3 (m+8), this pinion would require .003" (.08 mm) less shims than a pinion etched zero (0).

If the pinion is etched .3 (m-8), this would require .003" (.08 mm) more shims than a pinion etched zero (0).

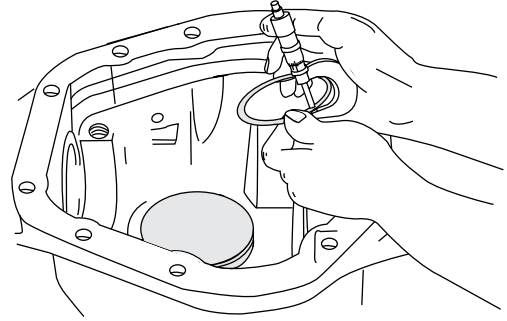

19. Measure each shim separately with a micrometer and add together to get total shim pack thickness. If baffle is required it is to be included in the shim pack.

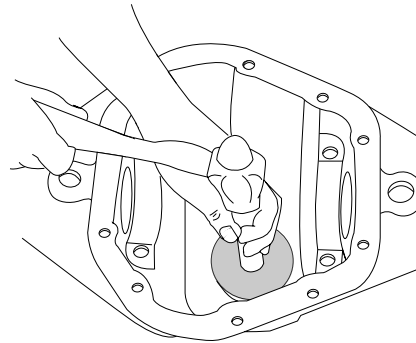

20. Place the required amount of shims (and baffle if used) in the inner bearing bore. Drive the inner bearing cup into the carrier. Make sure cup is seated.

TOOL:

D-111	Cup Installer
C-4171	Handle

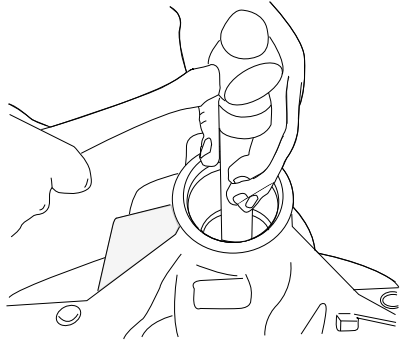

21. Assemble the outer pinion bearing cup into carrier as shown. Make sure cup is seated.

TOOL:

C-4203	Cup Installer
C-4171	Handle

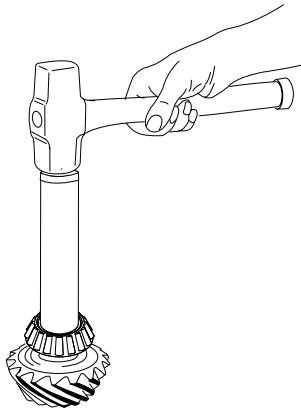

22. Assemble inner bearing cone (and slinger if used) on pinion. Drive bearing on shaft until it is completely seated.

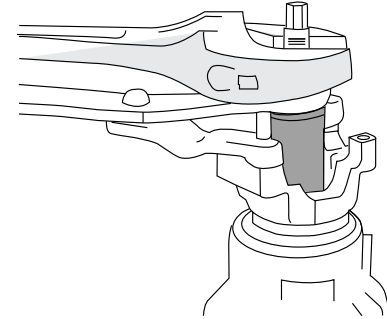

23. Assemble pinion into carrier. Assemble outer pinion bearing cone (and slinger if used) and end yoke onto pinion spline.

Note: Do not assemble preload shims or pinion oil seal at this time.

Use yoke installer as shown to assemble end yoke onto spline of pinion.

TOOL:

C-3718	Installer
C-3281	Holder

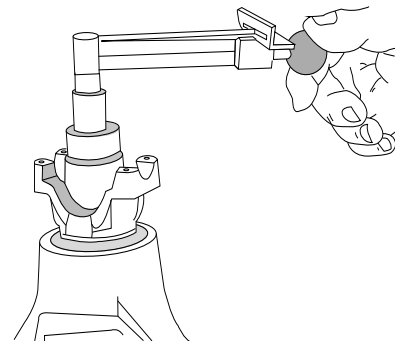

24. Assemble washer and pinion nut. Torque nut until it requires 10 lb. in. (1.13 N•m) to rotate the pinion. Rotate pinion several times before checking pinion position. This is to seat the bearings and assure a more accurate reading pinion depth setting.

TOOL:

D-193	in. lb. Torque Wrench
-------	-----------------------

Note: The reason for not assembling preload shims and new pinion seal at this time is due to the possibility of having to adjust pinion preload of pinion adjustment. It would be necessary to again remove the seal and, as mentioned, whenever seals are removed, they are to be replaced with new ones due to possible damage.

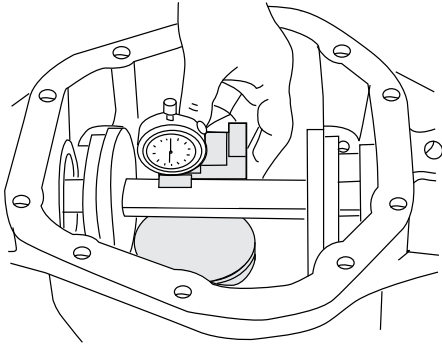

25. Place arbor and discs (small diameter discs for Model 60 axle and large diameter used on Model 70 axle) into cross bore of carrier. Place pinion height block on button end of pinion. Set dial indicator on small step of height block (high step of block is used for Model 79 axle). Set dial indicator at "0". Slide scooter gauge across or over arbor. Indicator will read a (+) or minus (-) at its highest point, depending on the etching of the pinion.

Note: Later model pinion height blocks are designed for each individual model axle. Therefore, it is possible to have a height block that does not have a step as pictured and described.

Note: Indicator reading within .002 in. (.05 mm) of etching is considered acceptable. If pinion position is found to be within specifications continue with build up. If pinion position is not within specifications, change shim pack thickness under inner bearing cup.

26. Remove pinion nut, washer, end yoke, slinger, and bearing cone. Assemble preload shims (which were removed during disassembly) and pinion. Assemble bearing cone and slinger.

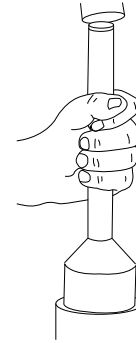

27. Apply a light coat of hypoid lubricant on the lip of pinion seal and assemble into carrier.

TOOL:

D-163	(National) Seal Installer
D-164	(Chicago Rawhide) Seal Installer
C-4171	Handle

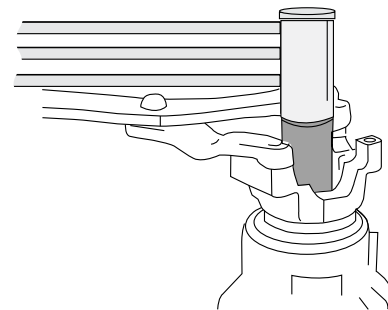

28. Assemble end yoke, washer, and new pinion nut. Torque nut to 240-300 lb. ft. (325-406 N•m).

C-4053	Torque wrench
C-3281	Yoke holder

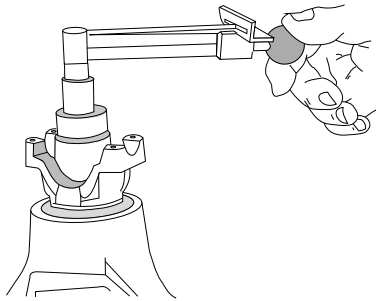

- 29.** Using an in. lb. torque wrench as shown, rotate pinion. Torque to rotate pinion should read between 20-40 lb. in (2.26-4.53 N•m). To increase preload, remove shims. To decrease preload add shims.

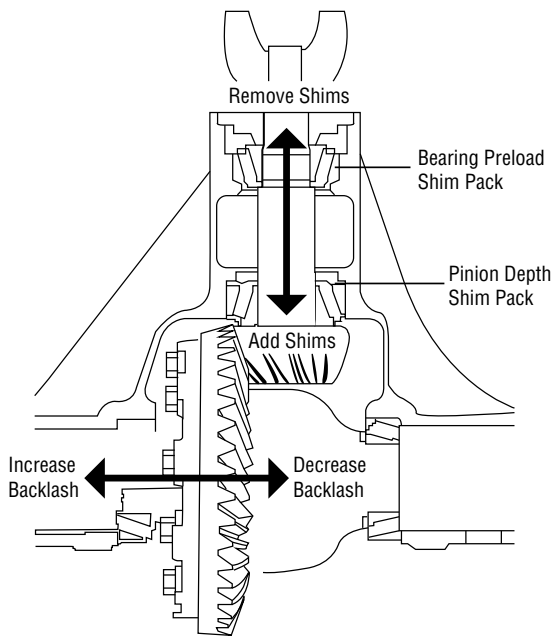

L/D Carrier

The illustration shows the arrow in the pinion pointing in two directions. The direction pointing towards the end yoke indicates that by removing pinion position shims, the distance from the centerline of the axle to pinion button is increased, giving a plus reading. The preload shim pack does not effect the pinion depth setting. Arrows on the ring gear illustrate the method to increase or decrease backlash and differential bearing preload.

Assembly of Differential

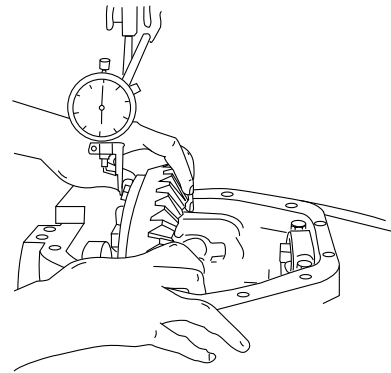

- 30.** Set up dial indicator as shown. Be sure to locate dial indicator on same location marked in Step 11. Force ring gear into mesh with pinion, rocking to allow the teeth of the gears to mesh. With force still applied to the differential case, set indicator at zero "0".

TOOL:

D-128	Indicator
-------	-----------

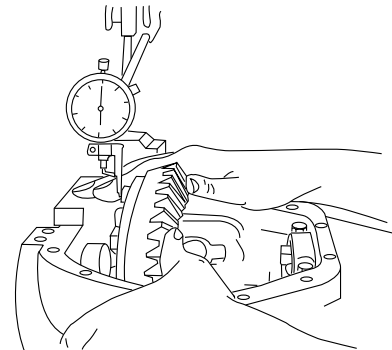

- 31.** Force the differential case (ring gear) away from the pinion gear to obtain an indicator reading. Repeat until the same reading is obtained each time. This reading will be the necessary amount of shims required between the differential case and differential bearings on the ring gear side. Remove indicator and differential case from carrier. Remove master bearings from differential case.

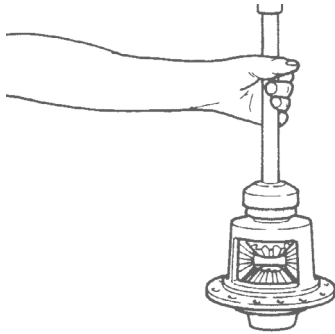

- 32.** Assemble the required amount of shims onto hub (ring gear side) as determined in Step 30. Place bearing cone on hub of case. Use bearing installer to seat bearing cone as shown.

TOOL:

C-4025-A	Installer
C-4171	Handle
D-914-42	Button

Assemble the remaining of the total shim pack which was determined in Step 12 on the opposite side of the differential case. Add an additional .015 in. (.38 mm) of shims to this side to compensate for differential bearing preload. Assemble differential bearing, using the same tools as shown in Figure 122.

In Step 12 (less pinion) a total of .107 in. indicator reading was recorded.

In Step 30 (with pinion) a total of .055 in. indicator reading was recorded. This leaves a balance .062 in. shims for the opposite side and adds up to the .107 in. which was first recorded.

Add an additional .015 in. shims on the opposite side for bearing preload and backlash.

Ring gear side: .055 in. (1.4 mm)

Opposite side: .052 in. (1.32 mm)

Opposite side preload: .015 in. (.38 mm)

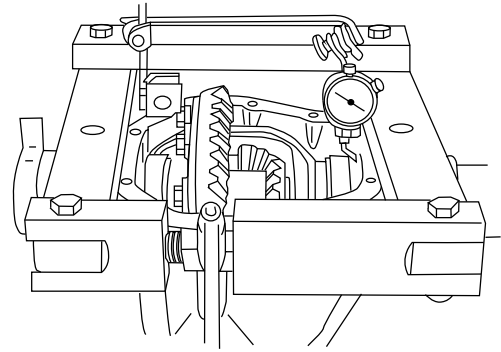

- 33.** Install spreader and indicator to carrier as shown. Do not spread carrier over .015 in. (.38 mm). Remove indicator.

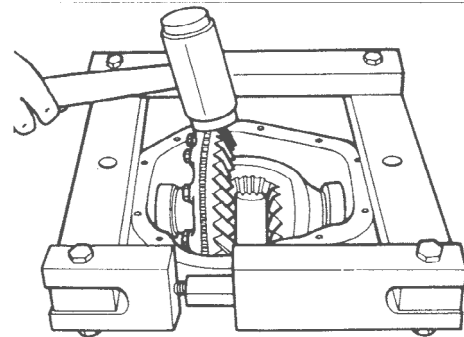

- 34.** Assemble differential bearing cups to differential bearing cones. Install differential assembly into carrier.

Use a rawhide hammer to seat differential assembly into cross bore of carrier. Care should be taken to avoid nicking the teeth of the ring gear and pinion during assembly. Remove spreader.

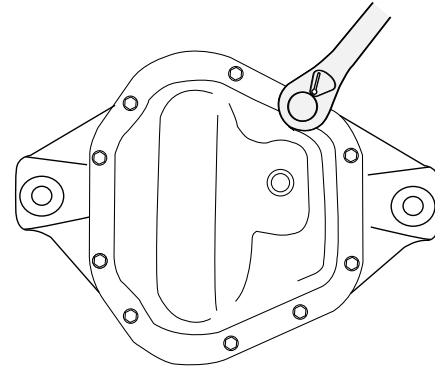
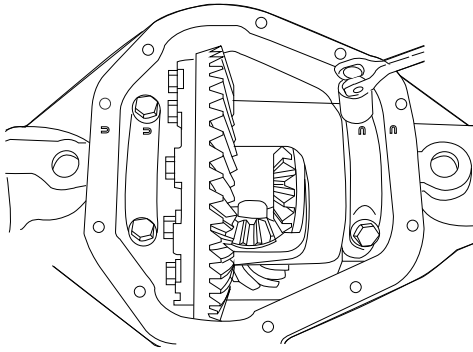

35. Install bearing caps. Make sure the letters stamped on the caps correspond with those on the carrier. Torque bearing cap screws to 80-90 lb. ft. (108-122 N•m).

TOOL:

C-524-A	Torque wrench
---------	---------------

37. Install new cover gasket and install cover plate. Torque screws to 20-40 lb. ft. (41-54 N•m).

TOOL:

C-524-A	Torque wrench
---------	---------------

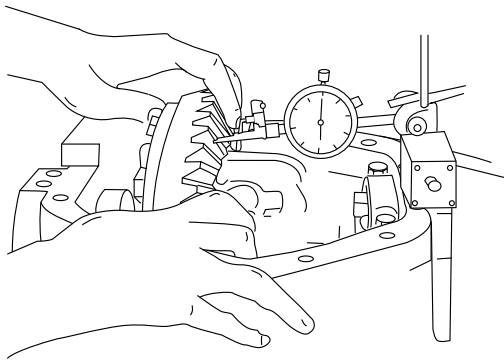

36. Check ring gear and pinion backlash in three equally spaced points with dial indicator as shown. Backlash tolerance is .004 in. (.10-.28 mm) to .009 in. and cannot vary more than .002 in. (.05 mm) between points checked.

High backlash is corrected by moving ring gear closer to the pinion. Less backlash is corrected by moving ring gear away from the pinion.

These corrections are made by switching shims from one side of the differential case to the other.

Note: If servicing the semi-float shaft riding bearing design unit, refer to the manual section for that unit. After installing axle shafts, a new lock pin is installed.

Service Tools List

Tool Number	Description	Tool Number	Description
D-111	Installer - Rear Pinion Bearing Cup	C-3281	Wrench - Universal Joint Flange or Yoke
D-115	Scooter Gauge*	C-3718	Installer - Universal Joint Flange or Yoke
D-115-3	Arbor*	C-4025-A	Installer - Differential Side Bearings
D-116-1	Pinion Height Block*	C-4026-A	Installer - Axle Shaft Outer Oil Seal
D-116-2	Arbor Discs*	SP-320	Washers
D-117	Master Bearing Differential*	SP-5017	Adapter Ring
D-120	Master Pinion Block*	SP-5026	Bolts
D-128	Dial Indicator Set	SP-5440	Adapter Ring - Installer
D-131	Puller - Slide Hammer	SP-5441	Adapter Set - Removing
D-158	Remover - Front Pinion Bearing Cup	SP-5443-A	Flange Plate
D-162	Remover - Rear Pinion Bearing Cup	D-195-2	Screw
D-163	Installer - Pinion Oil Seal (National)	D-195-1	Installer - Front Axle Differential Inner Oil Seal
D-167	Spreader - Differential Carrier	C-4171	Handle - Universal
C-452	Remover - Universal Joint Companion Flange or Yoke	C-4203	Installer - Front Pinion Bearing Cup
DD-914-P	Puller Press	D-232-1	Remover - Bearing
DD-914-7	Extension	D-247	Installer - Press
DD-914-8	Reducer Ring	D-248	Installer - Bearing
DD-914-9	Reducer Ring	D-233	Installer - Oil Seal
DD-914-42	Button	D-255	Cup Remover (Hub & Drum)
DD-914-62	Adapter Set - Differential Bearing Cones	D-257	Cup Remover
C-293-37	Adapter Set - Rear Pinion Bearing Cone	D-254	Installer - Cup (Outer-Hub & Rotor)
C-3095-A	Installer - Rear Pinion Bearing Cone	D-256	Installer - Cup (Inner-Hub & Rotor)
	* Pinion Setting Gauge and Master Differential Bearing Kit D-116-60	D-253	Seal Installer

For spec'ing or service assistance, call 1-877-777-5360 or visit our website at www.dana.com/cv

Dana Commercial Vehicle Products Group

3939 Technology Drive
Maumee, Ohio, USA 43537

www.dana.com/cv



SPICER®

Drivetrain Products

Application Policy

Capacity ratings, features, and specifications vary depending upon the model and type of service. Application approvals must be obtained from Dana; contact your representative for application approval. We reserve the right to change or modify our product specifications, configurations or dimensions at any time without notice.