

THE  
**ULTIMATE**



## This Ranger Doesn't Follow the Rules.

This 2017 Ford® Ranger®, affectionately named "Randi" by all the people who donated to and worked on the rig, was meant from the start to stand apart from the crowd. Those working on the build knew they had to begin with the best from the ground up, so they went straight for a pair of Ultimate Dana 60™ axles with lockers. Ultimate Dana 60s™ deliver optimal performance and maximum strength for lifted vehicles with larger tires. Like Ford, Dana is proud of our long heritage of building to the highest standards of toughness and durability.



**SPICER®**

[SpicerParts.com/BuildList](http://SpicerParts.com/BuildList) or for our e-catalog, [DanaAftermarket.com](http://DanaAftermarket.com)

#SpicerParts

© 2018 Dana Limited. All rights reserved.





THE  
**ULTIMATE**  
DANA  
**60™**

## Ultimate Dana 60™ Ford® Ranger® Build List

- Ultimate Dana 60™ Front Axle with Lockers and 5.38 Ratio
- Ultimate Dana 60™ Rear Axle with Lockers and 5.38 Ratio
- ARB Fridge Freezer 82QT
- ARB Modified Bumpers
- ARB On-Board High Performance 12 Volt Air Compressor
- BFGoodrich Krawler™ T/A® KX - 40x14.50R17/C 121 L Tires
- Currie Anti-Rock® Kit Rear Sway Bar End Links
- Custom 4 Link Front and Rear Lift Kits
- Custom Rock Sliders
- Custom Spare Tire Carrier
- Customer Fiberglass Front and Rear Fenders
- Customer Fiberglass Hood
- Factor 55® Winch Safety Thimble & Fairlead
- FOX® 2.5" Coil-Over Shocks
- Hi-Lift® Jack
- PSC™ Hydro Assist Steering Gear with Ram Assist
- Rigid Industries® Light Bar/Blocks
- Rigid Industries® Under Carriage Lights
- sPOD® Power Distribution System
- Synergy® Drag Links
- Synergy® Tie Rods
- Walker Evans Racing 17" Beadlock Wheels
- WARN® ZEON® 10 Winch

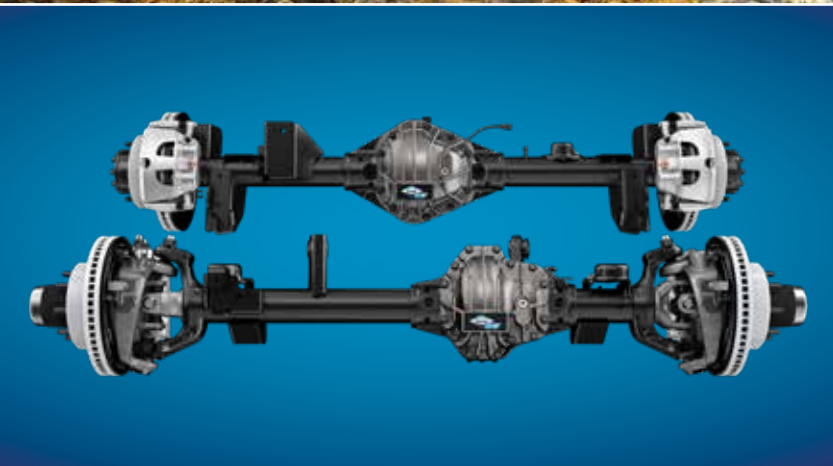

Spicer® Nodular Iron  
Differential Cover



©Copyright Dana Limited, 2018. All rights reserved. Dana Limited. Ultimate Dana 60™ is a registered trademark of Dana Limited. Ford and Ranger are registered trademarks of Ford Motor Company. The ARB 4x4 Accessories name and logos are trademarks of ARB Corporation limited. BFGoodrich, Krawler and T/A are trademarks and copyrights of Michelin North America, Inc. Currie Anti-Rock is a registered trademark of Currie Enterprises, Inc. Factor 55 is a registered trademark of Factor 55 Precision Engineering. FOX is a registered trademark of FOX Factory, Inc. Hi-Lift Jack Company logo is a registered trademark of Hi-Lift Jack Company. PSC is a trademark of PSC Motorsports. Rigid Industries LED Lighting® is a registered trademark of Rigid Industries. sPOD is a trademark of Precision Designs, LLC. Synergy is a trademark of Synergy Manufacturing. Walker Evans Racing is a trademark of Walker Evans Enterprises Incorporated. Warn is a trademark of Warn Industries, Inc.

Product information: [SpicerParts.com](http://SpicerParts.com)  
E-catalog and parts locator: [DanaAftermarket.com](http://DanaAftermarket.com)