

Spicer® Drive Axles

SPICER®



Illustrated Parts List

Spicer® Single Speed Drive Axles

AXIP-0866

October 1999

J175-S, J190-S
J210-S, J220-S
J230-SB, W230-S

TABLE OF CONTENTS

Model Identification Numbering System i
 Julian Date Code 1
 Axle Identification 1
 Components 2
 Parts List 3-4
 Axle Shafts 4
 Housings 5
 End Yoke Assemblies 6
 Pinion Bearing Spacers 7
 Pinion Bearing Cage Shim 7
 Kits 8

- Pinion Bearing Spacers
- Ring Gear and Pinion
- Differential Parts
- Differential Cases
- Differential Bearings and Seals



GENUINE SPICER SERVICE PARTS

Should an axle assembly require replacement component parts, it is recommended that Spicer Heavy Axle Service Parts be used. Spicer Heavy Axle Service Parts are manufactured under the same rigid specification as are original equipment axle components. This assures the customer who uses genuine Spicer service parts, maximum reliability for a Spicer Heavy Axle assembly. They may be obtained through your vehicle manufacturer. The use of non-original Spicer service parts may cause premature component failure and may void the warranty.

The items included in this book are currently being offered as service parts at the time of printing. The part numbers and illustrations are provided specifically for reference purposes only. Therefore, Spicer reserves the right to update this manual without notice or liability.

MODEL IDENTIFICATION NUMBERING SYSTEM

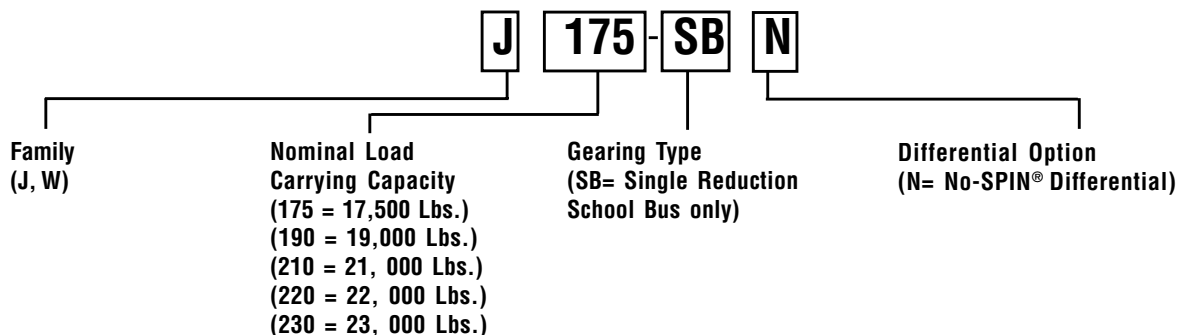

JULIAN DATE CODE

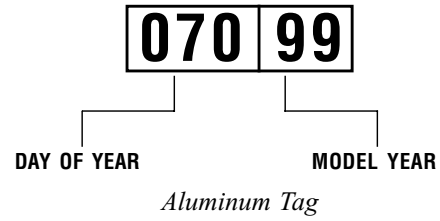
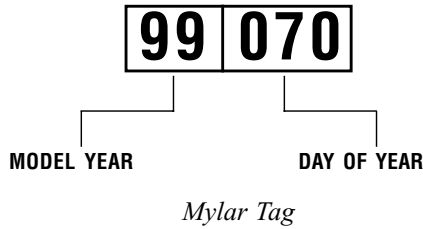

AXLE IDENTIFICATION

All axle assemblies are identified with two tags. One located on the differential carrier, and the other located on the right hand side of the axle housing. Two types of tags may be found on the axle, an aluminum tag that is riveted on the assembly or a coated mylar tag.

The aluminum **differential carrier tag** contains the following items: serial number, according to the julian date code, the Dana part number, and ratio. The mylar **differential carrier tag** contains the following: Dana part number, julian date code, and ratio. Optional items

include customer part number, line set number, and the last six digits of the vehicle serial number.

The aluminum **axle assembly tag** contains the following items: serial number, according to the julian date, Dana part number, and the model. The mylar **axle assembly tag** contains the following items: Dana part number, julian date code, axle model, and ratio. Optional items include customer part number, line set number, and the last six digits of the vehicle serial number.

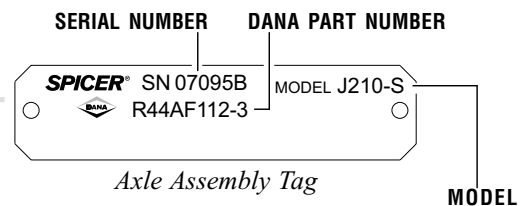
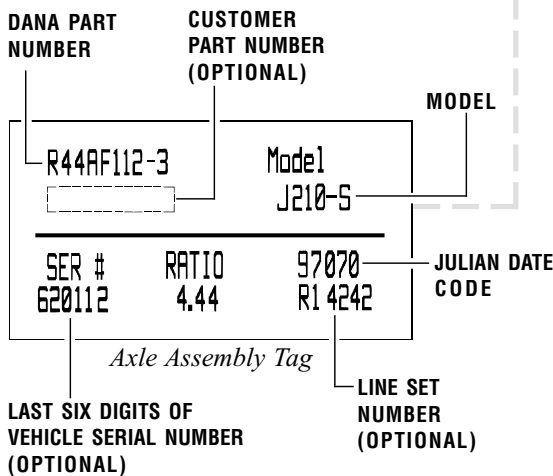
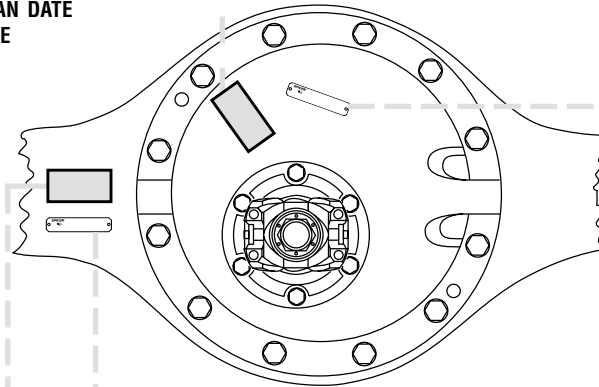
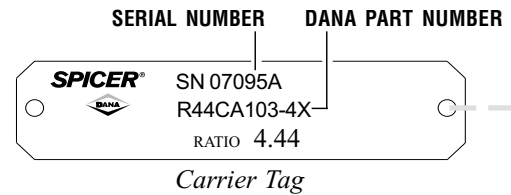
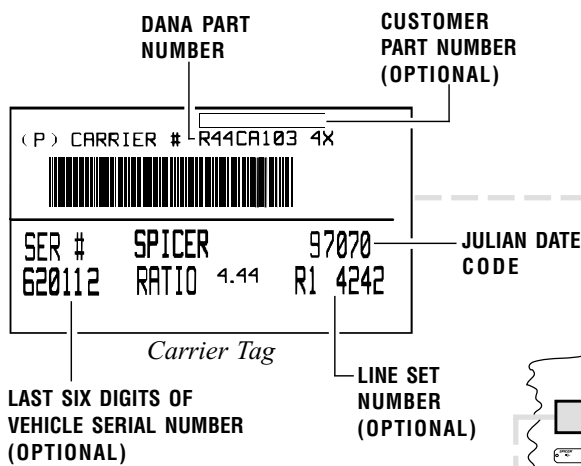

COMPONENTS

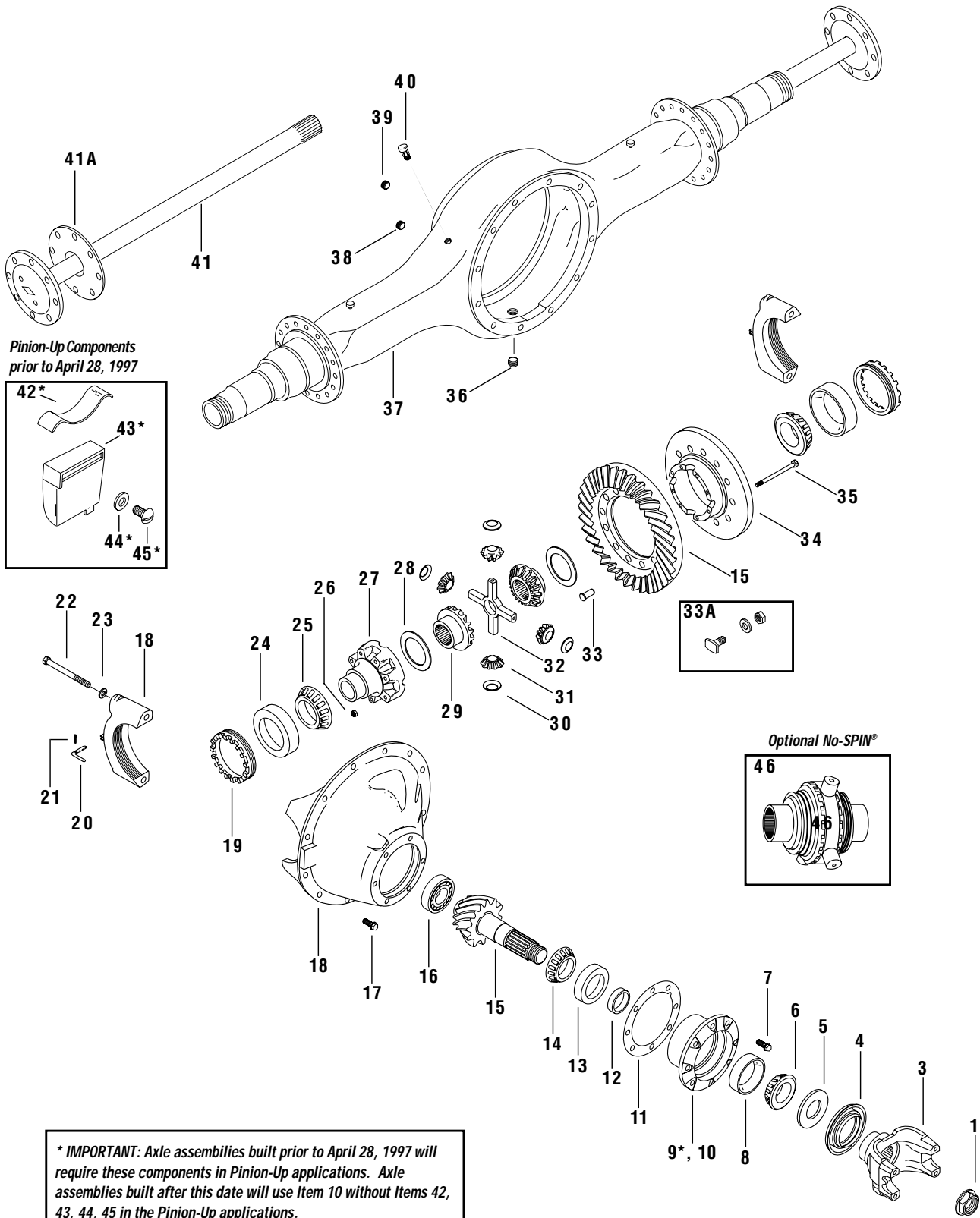

*** IMPORTANT:** Axle assemblies built prior to April 28, 1997 will require these components in Pinion-Up applications. Axle assemblies built after this date will use Item 10 without Items 42, 43, 44, 45 in the Pinion-Up applications.

PARTS LIST

Item	Part Name	Qty.	J175-S	J190-S/J210-S	J220-S/J230-SB*	W230-S
1+	Pinion Nut (**See Note)	1	HN162	HN162	HN162	HN162
3	End Yoke Assembly	1		See Page 6 for correct part numbers		
4+	Pinion Oil Seal	1	HH105	HH105	HH105	HH105
	After 7/15/91	1	GGAHH103	GGAHH103	GGAHH103	GGAHH103
	Before 7/15/91	1	----	----	----	892790R1
5	Bearing Preload Spacer	1	----	----	----	892790R1
6+	Outer Pinion Bearing Cone	1	360HB100	360HB100	360HB100	483067C91
7	Bearing Cage Bolt	6	HM117	HM117	HM117	HM111
8+	Outer Pinion Bearing Cup	1	360HA100	360HA100	360HA100	483068C1
9	Bearing Cage w/ Cups (Pinion Up)	1	591367C91	591367C91	591367C91	057CP106-X
10	Bearing Cage w/ Cups (Standard)	1	454719C91	454719C91	454719C91	482782C91
11	Pinion Bearing Cage Shim	1		See Page 7 for correct part numbers		
12+	Pinion Preload Spacer (Selective)	1		See Page 7 for correct part numbers		
13+	Inner Pinion Bearing Cup	1	360HA100	360HA100	360HA100	HA100
14+	Inner Pinion Bearing Cone	1	360HB100	360HB100	360HB100	HB103
15+	Pinion & Ring Gear Set	1		See Page 8 for kit		
16+	Pinion Pilot Bearing	1	91082R91	91082R91	91082R91	472658C91
17	Carrier Mounting Bolt					
	Grade 8, 5/8" 11 UNC x 1-3/4"	12	HM109	HM109	HM109	----
	Grade 8, 5/8" 11 UNC x 2-1/4"	2	----	----	----	HM110
	Grade 8, 5/8" 11 UNC x 1-3/4"	10	----	----	----	HM109
18	Carrier Sub-Assembly (Includes Items 22 & 23)	1	161019R93	161019R93	161019R93	451918C92
19	Adjusting Ring	2	69208R1	69208R1	69208R1	161066R1
20	Adjusting Ring Lock	2	157491R2	157491R2	157491R2	157491R2
21	Cotter Pin (3/16" x 1")	2	103407	103407	103407	103407
22	Differential Bearing Cap Bolt	4	HM200	HM200	HM200	HM202
23	Differential Bearing Cap Washer	4	HN125	HN125	HN125	HN125
24	Differential Bearing Cup	2	ST2161	ST2161	ST2161	HA101
25	Differential Bearing Cone	2	ST2162	ST2162	ST2162	HB102
26+	Differential Case Nut	8	274638	274638	274638	274639
27+	Differential Case Cap Half	1	864358R2	864358R2	864358R2	161080R3
28+	Differential Gear Thrustwasher	2				
29+	Differential Side Gear	2				
30+	Differential Pinion Thrustwasher	4				
31+	Differential Pinion Mate	4				
32+	Differential Cross Shaft	1				
33	Ring Gear Rivet	12	HM204	HM204	HM204	HM203
33A+	Ring Gear Bolt Kit	1	401KY101-X	401KY101-X	401KY101-X	057KY101-X
34+	Differential Case Flange Half					
	3.54 Ratio	1	584281C1	584281C1	584281C1	584284C1
	3.73 thru 4.44 Ratios	1	505756C1	505756C1	505756C1	208523R5
	4.78 thru 8.17 Ratios	1	505757C1	505757C1	505757C1	161091R5
35+	Differential Case Bolt					
	3.54 Ratio	8	HM123	HM123	HM123	HM114
	3.73 thru 4.44 Ratios	8	HM122	HM122	HM122	HM113
	4.78 thru 8.17 Ratios	8	HM121	HM121	HM121	HM112
36	Magnetic Drain Plug	1	HM232	HM232	HM232	HM232
37	Axle Housing	1		See Page 5 for correct part numbers		
38	Temperature Sensor Plug	1	MJAHM115	MJAHM115	MJAHM115	MJAHM115
39	Filler Plug	1	MJAHM120	MJAHM120	MJAHM120	MJAHM120
40	Vent Plug	1	MJAHN110	MJAHN110	MJAHN110	MJAHN110
41	Axle Shaft	2		See Page 4 for correct part numbers		

* Item included in Kits

* J230-SB model used for school bus applications

PARTS LIST (CONTINUED)

Item	Part Name	Qty.	J175-S	J190-S/J210-S	J220-S/J230-SB*	W230-S
41A	Gasket, Axle Shaft use w/ MJASR103-1	1	----	----	MJAHG105(J230)	----
	Gasket, Axle Shaft use w/ MJASR127	1	----	HG104	----	----
	Gasket, Axle Shaft use w/ 571348C2	1	HG106	----	----	----
	Gasket, Axle Shaft use w/ 571350C2/MJASR124	1	----	----	057HG101(J220)	----
42	Retainer - Pinion Up	1	236871R1	----	236871R1	----
43	Scoop - Pinion Up	1	868467R91	----	868467R91	----
44	Washer - Pinion Up	1	500365-12	----	500365-12	----
45	Screw - Pinion Up	1	500500-1	----	500500-1	----
46	No-SPIN® Differential (Optional)					
	1.875" x 36 Splines	1	589789C91	----	----	----
	2.000" x 39 Splines	1	----	579365C91	----	----
	2.125" x 41 Splines	1	----	----	390GN100	----
	2.375" x 46 Splines	1	----	----	----	057GN100

* J230-SB model used for school bus applications

AXLE SHAFTS

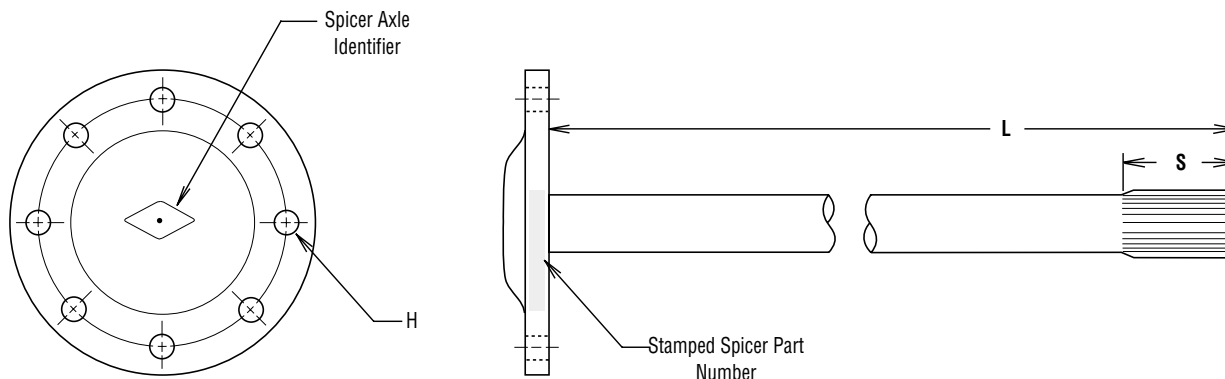

-S- Spline Size	-L- Length	-H- Hole Type	J175-S	J190-S/J210-S	J220-S	J230-SB	W230-S
3.228" x 36	39.70"	Straight	571348C2	----	----	----	----
2.491" x 39	40.25"	Tapered	----	MJASR127	----	----	----
		Straight	----	571349C2	----	----	----
2.835" x 41	40.00"	Straight	----	----	571350C2	----	----
3.500" x 41	40.72"	Tapered	----	----	MJASR124	----	----
3.500" x 41	40.72"	Tapered	----	----	----	MJASR103-1	----
2.835" x 46	39.98"	Straight	----	----	----	----	230SR100-1
2.835" x 46	40.84"	Tapered	----	----	----	----	057SR102-1

HOUSINGS

Suspension	J175-S	J190-S/J210-S	J220-S	J230-SB	W230-S
4 Spring - Standard (Excluding J210-S)	042CH100	R44CH100	047CH108		057CH100
		R44CH110	047CH105	047CH106	057CH108
		R44CH121	047CH110	047CH110	057CH110
		R44CH122			057CH114
		R44CH124			057CH121
		R44CH126			
ABS Option	----	R44CH138	047CH108	047CH119	057CH110
		R44CH139		047CH108	057CH120
4 Spring - Standard (J210-S Only)	----	R44CH105	----	----	----
		R44CH125			
		R44CH130			
ABS Option	----	R44CH116	----	----	----
		R44CH123			
		R44CH131			
4 Spring - Standard (Pinion Up)	042CH105	R44CH111	----	047CH111	----
		R44CH113		047CH113	
		R44CH129		047CH115	
		R44CH132		047CH116	
		R44CH135		047CH117	
ABS Option	----	R44CH137	----	047CH118	057CH117
		R44CH123			057CH123
Air (Excluding J210-S)	----	----	047CH104	----	474CH102
			472CH126		
ABS Option	----	----	472CH126	----	057CH111
Air (J210-S Only)	----	R44CH117	----	----	----
		R44CH136			
ABS Option	----	R44CH117	----	----	----
		R44CH133			
Air (Pinion Up)	----	R44CH128	----	----	057CH118
ABS Option	----	R44CH128	----	----	057CH119
Bare	----	----	----	----	057CH104

END YOKES ASSEMBLIES

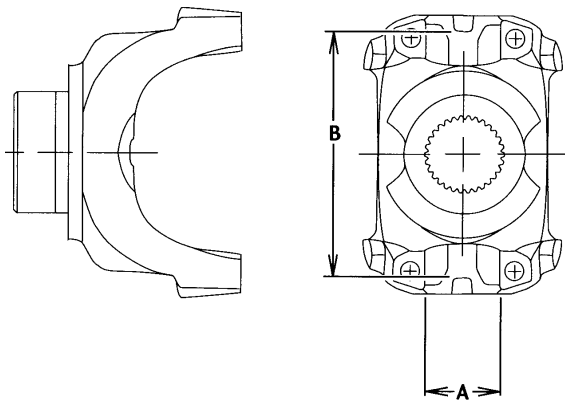

HR, BS, UB, CV
Style

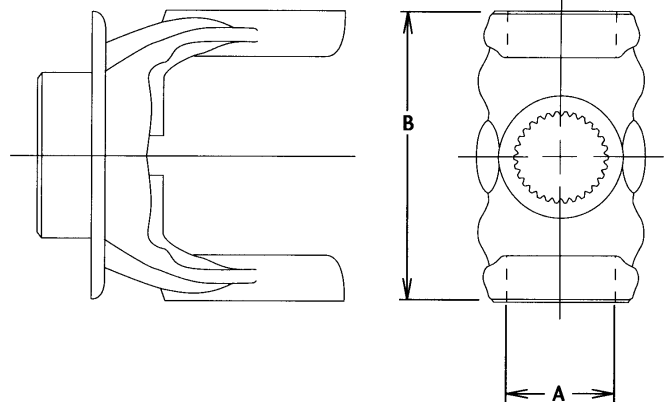

BP
Style

ITEM 3							
Series	A	B	Spline	Joint Angle	Style	Previous Part Number	Spicer Part Number
1480	1.38"	4.19"	2.114" - 32	18°	BS	3-4-12141-1X	3-4-13351-1X
1550	1.38"	4.97"	2.114" - 32	23°	BS	4-4-5521X	4-4-7001-1X
1550	1.38"	4.97"	2.364" - 36	22°	BS	4-4-5541X	4-4-7111-1X
1610	1.88"	5.31"	2.114" - 32	33.5°	HR	5-4-7221X	5-4-8611-1X
1610	1.88"	5.31"	2.364" - 36	21°	HR	5-4-7201X	5-4-8631-1X
1610	1.88"	5.31"	2.114" - 32	45°	HR	5-4-7181X	5-4-8691-1X
1610	1.88"	5.31"	2.364" - 36	33.5°	BP	5-4-7231X	5-4-7231-X
1610	----	----	2.114" - 32	N/A	CF	----	5-1-6701-X
1710	1.94"	6.09"	2.114" - 32	24°	HR	6-4-7221-1X	6-4-8681-1X
1710	1.94"	6.09"	2.364" - 36	22°	HR	6-4-7191X	6-4-8701-1X
1760	1.94"	7.00"	2.364" - 36	30°	HR	6.3-4-1021X	6.3-4-1541-1X
1810	1.94"	7.55"	2.364" - 36	30°	HR	6.5-4-3651X	6.5-4-4421-1X

HR (Half Round), BS (Bearing Strap), UB (U-Bolt),
CV (Constant Velocity), BP (Bearing Plate), CF (Companion Flange)

PINION BEARING SPACERS

J MODEL - ITEM 12

Thickness		Spicer Part Number
Inches	MM	
.718	18.237	042HS101-1
.719	18.263	042HS101-2
.720	18.288	042HS101-3
.721	18.313	042HS101-4
.722	18.339	042HS101-5
.723	18.364	042HS101-6
.724	18.390	042HS101-7
.725	18.415	042HS101-8
.726	18.440	042HS101-9
.727	18.466	042HS101-10
.728	18.491	042HS101-11
.729	18.517	042HS101-12
.730	18.542	042HS101-13
.731	18.567	042HS101-14
.732	18.593	042HS101-15
.733	18.618	042HS101-16
.734	18.644	042HS101-17
.735	18.669	042HS101-18
.736	18.694	042HS101-19
.737	18.720	042HS101-20
.738	18.745	042HS101-21
.739	18.771	042HS101-22
.740	18.796	042HS101-23
.741	18.821	042HS101-24
.742	18.847	042HS101-25
.745	18.923	042HS101-26

Available as Spacer Kit

W MODEL - ITEM 12

Thickness		Spicer Part Number
Inches	MM	
.893	22.682	474HS101-1
.894	22.708	474HS101-2
.895	22.733	474HS101-3
.896	22.758	474HS101-4
.897	22.784	474HS101-5
.898	22.809	474HS101-6
.899	22.835	474HS101-7
.900	22.860	474HS101-8
.901	22.885	474HS101-9
.902	22.911	474HS101-10
.903	22.936	474HS101-11
.904	22.962	474HS101-12
.905	22.987	474HS101-13
.906	23.012	474HS101-14
.907	23.038	474HS101-15
.908	23.063	474HS101-16
.909	23.089	474HS101-17
.910	23.114	474HS101-18
.911	23.139	474HS101-19
.916	23.266	474HS101-20

Available as Spacer Kit

SPACER KIT

Range	Spicer Part Number
J Model .731 thru .740	042KV100-X
W Model .906 thru .916	474KV100-X

PINION BEARING CAGE SHIM

J MODEL - ITEM 11

Thickness		Spicer Part Number
Inches	MM	
.005	.127	042HS104-3
.010	.254	042HS104-1
.030	.762	042HS104-2

W MODEL - ITEM 11

Thickness		Spicer Part Number
Inches	MM	
.005	.127	057HS104-3
.010	.254	057HS104-1
.030	.762	057HS104-2

KITS

RING GEAR AND PINION					
Ratio	J175-S	J190-S/J210-S	J220-S/J230-SB	W230-S	Included Items
3.54	597236C91	597236C91	597236C91	597247C91	1, 2**, 15
3.73	597237C91	597237C91	597237C91	597248C91	
3.91	597238C91	597238C91	597238C91	597249C91	
4.10	597239C91	597239C91	597239C91	597250C91	
4.44	597240C91	597240C91	597240C91	597251C91	
4.78	597241C91	597241C91	597241C91	597252C91	
5.38	597242C91	597242C91	597242C91	597253C91	
6.14	597243C91	597243C91	597243C91	597254C91	
6.57	597244C91	597244C91	597244C91	597255C91	
7.17	597245C91	597245C91	597245C91	597256C91	
8.17	597246C91	597246C91	597246C91	----	

**Note: Use a HN139 Pinion Nut Washer / HN163 Pinion Nut combination with a 1480 series End Yoke.

DIFFERENTIAL PARTS					
Spline Description	J175-S	J190-S/J210-S	J220-S/J230-SB	W230-S	Included Items
1.875" x 16	042KR100-X	----	----	----	28, 29, 30, 31, 32
1.875" x 36	472KS107-X	----	----	----	
2.000" x 16	----	R44KR100-X	----	----	
2.000" x 39	----	472KS108-X	----	----	
2.125" x 20	----	----	047KR100-X	----	
2.125" x 41	----	----	472KS109-X	----	
2.328" x 22	----	----	----	057KR100-X	
2.375" x 46	----	----	----	472KS110-X	

DIFFERENTIAL CASES					
Ratio	J175-S	J190-S/J210-S	J220-S/J230-SB	W230-S	Included Items
3.54	586702C91	586702C91	586702C91	586703C91	26, 27, 34, 35
3.73 thru 4.44	493204C91	493204C91	493204C91	493206C91	
4.78 thru 8.17	493205C91	493205C91	493205C91	493207C91	

DIFFERENTIAL BEARINGS AND SEA					
J175-S	J190-S/J210-S	J220-S/J230-SB	W230-S	Included Items	
472KS101	472KS101	472KS101	474KS101	4, 6, 8, 13, 14, 16, 24, 25	



SPICER®

Drivetrain Products

Axles
Driveshafts
Off-Highway Transmissions

LONG®

Thermal Products

Transmission Oil Coolers
Engine Oil Coolers

VICTOR REINZ®

Sealing Products

Gaskets and Seals
Cylinder-Head Cover Modules
Thermal-Acoustic Protective Shielding



Dana Aftermarket Group
PO Box 321
Toledo, Ohio 43697-0321

Warehouse Distributor: 1.800.621.8084
OE Dealers: 1.877.777.5360

www.spicerparts.com

SPICER®

