



# Service Manual

---

**Single Reduction with Wheel Differential Lock**

**AXSM-0074**

**February 2018**

D40-157D

D40-157S

D40-157X

# General Information

---

## General Information

The description and specifications contained in this service publication are current at the time of printing. Dana reserves the right to discontinue or to modify its models and/or procedures and to change specifications at any time without notice.

Any reference to brand names in this publication is made simply as an example of the types of tools and materials recommended for use and should not be considered an endorsement. Equivalents, if available, may be used.

## Important Notice

This symbol is used throughout this manual to call attention to procedures where carelessness or failure to follow specific instructions may result in personal injury and/or component damage.

Departure from the instructions, choice of tools, materials and recommended parts mentioned in this publication may jeopardize the personal safety of the service technician or vehicle operator.

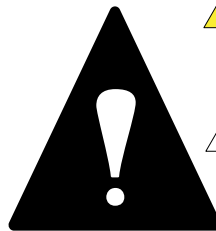

 **WARNING:** Failure to follow indicated procedures creates a high risk of personal injury to the servicing technician.

 **CAUTION:** Failure to follow indicated procedures may cause component damage or malfunction.

 **IMPORTANT:** Highly recommended procedures for proper service of this unit.

**Note:** Additional service information not covered in the service procedures.

**TIP:** Helpful removal and installation procedures to aid in the service of this unit.

[Always use genuine Spicer replacement parts.](#)

**Note:** Interactive PDF functions may not work correctly unless viewed using the free [Adobe Acrobat Reader](#).

# Table of Contents

---

## Introduction

Model Listing.....	1
Drive Axle.....	2
Part Identification.....	2

## Inspection

Failure Analysis.....	4
How to Diagnose a Failure.....	4
Prepare the Parts for Inspection.....	5
Find the Cause of the Failure.....	5
Correct the Cause of the Problem.....	5
Inspect Axle Housing.....	6
Inspect Components.....	6
Inspect Primary Gearing.....	7
Check Input Shaft End-play (Forward Axle).....	7
Check Output Shaft End-play (Forward Axle).....	7

## Tandem Axle

Tandem Axle Assemblies.....	8
-----------------------------	---

## Forward Assembly

Differential Carrier Assembly - Forward.....	9
Install Differential Carrier - Forward.....	10
Inter-Axle Lockout Types - Forward.....	11
Disassemble Lockout.....	12
Install Lockout.....	12
Power Divider - Forward.....	13
Disassemble, Assemble and Overhaul Power Divider - In Vehicle.....	14
Install Power Divider to Carrier Assembly - In Vehicle.....	17
Disassemble, Assemble and Overhaul Power Divider - Out of Vehicle.....	19
Install Power Divider to Carrier Assembly - Out of Vehicle.....	22
Lube Pump Disassembly.....	24
Lube Pump Installation.....	24
Lube Manifold Disassembly.....	25
Lube Manifold Installation.....	25
Measure and Adjust Input Shaft End-Play.....	27
Carrier Assembly - Forward.....	29
Disassemble Carrier Assembly.....	30
Disassemble Wheel Differential (All Standard Models).....	31
Disassemble Pinion Assembly.....	32
Front Axle Pinion Assembly - Forward.....	33
Disassemble and Overhaul Drive Pinion.....	34
Replace Pinion Bearing Cage Cups.....	35
Adjust Pinion Bearing Preload.....	36
Final Buildup.....	37
Install Drive Pinion Assembly.....	40
Wheel Differential - Forward.....	41
Disassemble, Overhaul, and Assemble Wheel Differential - Forward.....	42
Overhaul and Assemble Wheel Differential.....	43
Measure and Adjust Carrier Assembly.....	45
Change Backlash Setting.....	46
Measure Ring Gear Runout.....	46

Adjust Ring and Pinion Tooth Contact Pattern.....	47
Adjust Pinion Position.....	48
Adjust Ring Gear Position (Backlash).....	48
Wheel Differential Lock - Forward.....	49
Install and Adjust Wheel Differential Lock.....	50
Install and Adjust Ring Gear Thrust Bolt.....	51
Housing and Output Shaft Assembly - Forward.....	52
Disassemble Output Shaft Assembly.....	53
Overhaul and Assemble Output Shaft Assembly.....	54
Measure and Adjust.....	56
Replace Seal.....	56
Guidelines for Reusing Yoke.....	57

## Rear Assembly

Differential Carrier Assembly - Rear - Rear.....	58
Differential Carrier - Rear.....	59
Install Differential Carrier - Rear.....	60
Drive Pinion.....	61
Pinion Disassembly.....	62
Pinion Installation.....	63

## Wheel Differential

Wheel Differential Assembly.....	65
Disassemble, Overhaul, and Assemble Wheel Differential.....	66
Assemble Wheel Differential.....	68

## Forward Carrier

Forward Carrier – Assembly.....	71
Measure Ring Gear Runout.....	75

## Wheel Differential

Adjust Ring and Pinion Tooth Contact Pattern.....	76
---	----

## Seals

Service Kit 217414.....	78
-------------------------	----

## Lubrication

General Lubrication Information.....	79
Lube Change Intervals.....	80
Change Lube.....	81

## Wheel End Seal

Wheel End Seal - Parts Exploded View.....	82
Disassemble and Overhaul Wheel End Seal.....	83
Verify Wheel End-play Procedure.....	84
Lubricate Wheel End.....	85

## Vehicle Towing

Proper Vehicle Towing.....	86
----------------------------	----

## Theory of Operation

Power Divider Operation (Power Flow and Torque Distribution).....	87
Operate Wheel Differential Assembly.....	89
Wheel Differential Lock.....	90
Differential Lock Engaged.....	91
Differential Lock Disengaged.....	91

### **Parts Identification**

Power Divider - Forward.....	92
Front Drive Axle.....	93
Wheel Differential Lock Assembly .....	94
Parts Exploded View.....	95
Housing and Output Shaft Assembly.....	96

### **Torque Specifications**

Fastener Torque Specifications.....	97
-------------------------------------	----

## Introduction

Dana Spicer Corporation, Commercial Vehicle Division, presents this publication to aid in maintenance and overhaul of Dana Spicer single drive axles. Instructions contained cover the models listed. Their design is common, with differences in load capacity. Capacity variations are achieved by combining basic differential carrier assemblies with different axle housings, axle shafts and wheel equipment.

## Model Listing

Tandem Axles	Load Capacity
D40-157	40,000 Lbs [18,144 kg]

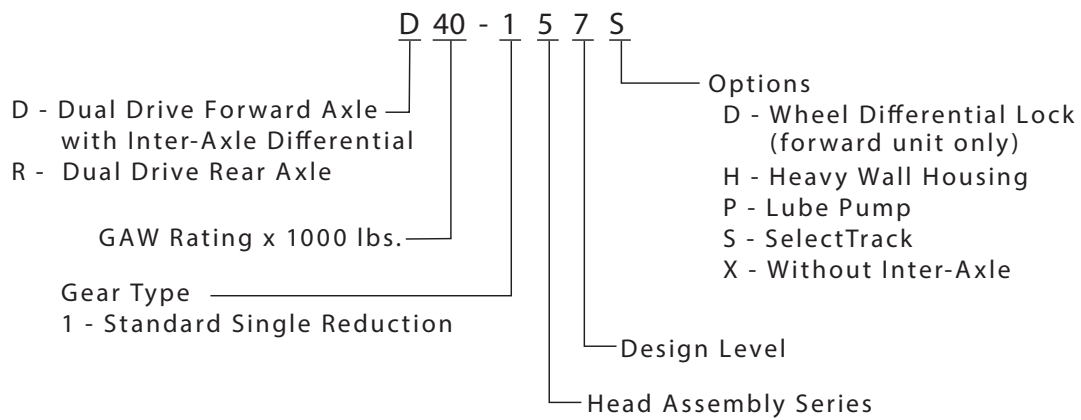

Drive Axle

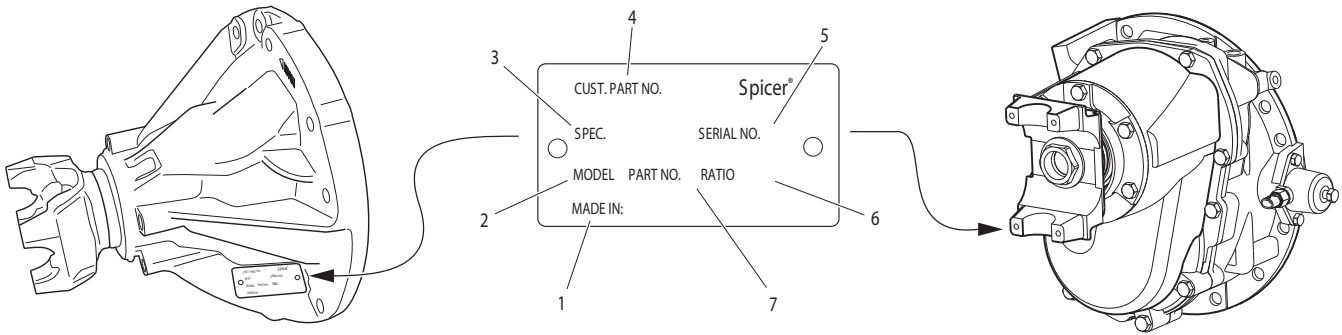

Rear Carrier

Forward Carrier

- |   |   |
|---|---|
| <ul style="list-style-type: none"> <li><b>1</b> — Country of origin</li> <li><b>2</b> — Axle model identification</li> <li><b>3</b> — Specification number assigned to the axle built by Dana Spicer. Identifies all component parts of the axle including special OEM requirements such as yokes or flanges</li> </ul> | <ul style="list-style-type: none"> <li><b>4</b> — OEM part number assigned to the axle build</li> <li><b>5</b> — Carrier assembly serial number assigned by the manufacturing plant</li> <li><b>6</b> — Axle gear ratio</li> <li><b>7</b> — Carrier assembly production or service part number</li> </ul> |
|---|---|

Part Identification

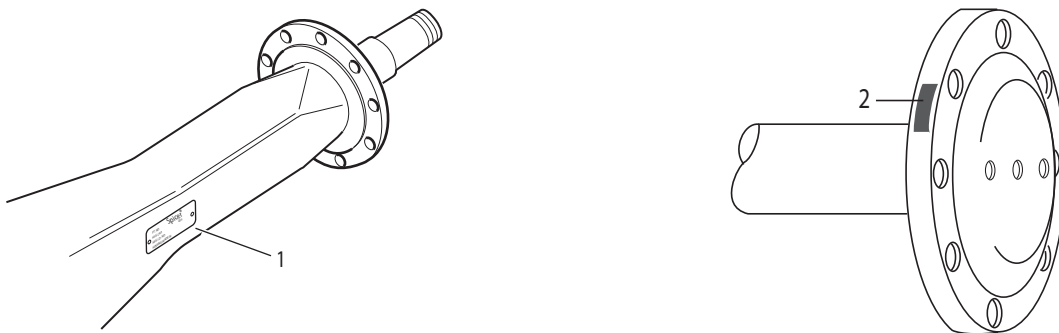

- 1** — ID Tag
- 2** — Axle shaft part number

## Ring Gear and Pinion

**Note:** Ring gear and drive pinion are matched parts and must be replaced in sets.

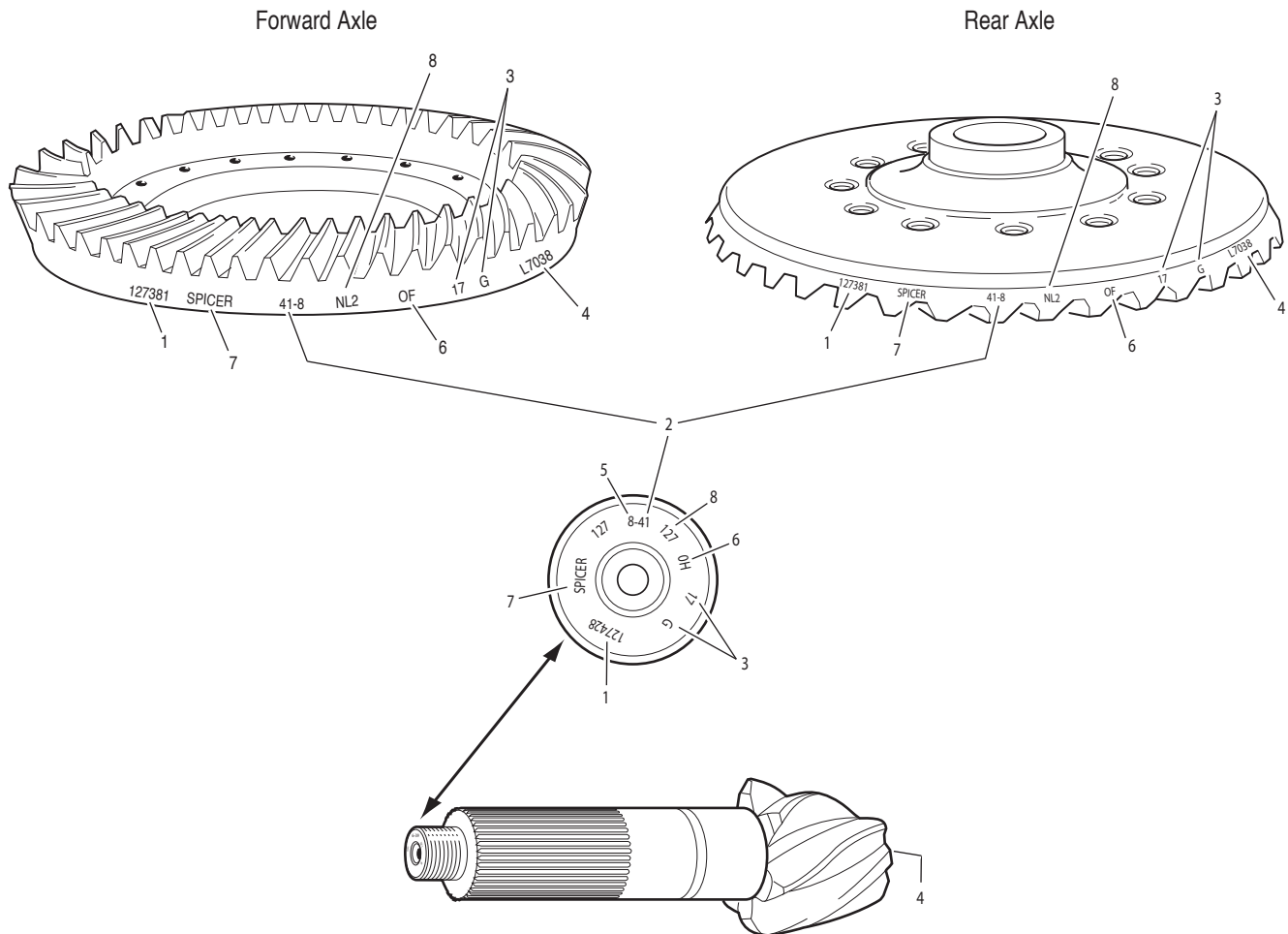

- 1 — Part number
- 2 — Number of ring gear teeth
- 3 — Manufacturing numbers
- 4 — Matching gear set number

- 5 — Number of pinion teeth
- 6 — Date code
- 7 — Indicates genuine Dana Spicer parts
- 8 — Heat Code

## Inspection

### Failure Analysis

Failure analysis is the process of determining the original cause of a component failure in order to keep it from happening again. Too often, when a failed component is replaced without determining its cause, there will be a recurring failure. If a carrier housing is opened, revealing a ring gear with a broken tooth, it is not enough to settle on the broken tooth as the cause of the carrier failure. Other parts of the carrier must be examined. For a thorough understanding of the failure and possible insight into related problems, the technician needs to observe the overall condition of the vehicle.

No one benefits when a failed component goes on the junkpile with the cause unknown. Nothing is more disturbing to a customer than a repeat failure. Systematically analyzing a failure to prevent a repeat occurrence assures quality service by avoiding unnecessary downtime and further expense to the customer.

The true cause of a failure can be better determined by knowing what to look for, determining how a piece of the equipment was running and learning about previous problems. In the case of a rebuilt rear axle, mismatched gears may have been installed. The more successful shops prevent repeat equipment failures by developing good failure analysis practices. Knowing how to diagnose the cause of a premature failure is one of the prerequisites of a good heavy-equipment technician.

### How to Diagnose a Failure

The following five steps are an effective approach to good failure diagnostics.

1. Document the problem.
2. Make a preliminary investigation.
3. Prepare the parts for inspection.
4. Find the cause of the failure.
5. Correct the cause of the problem.

### Document the Problem

Here are some guidelines for starting to learn about a failure, including questions to ask:

1. Talk to the operator of the truck.
2. Look at the service records.
3. Find out when the truck was last serviced.

4. Ask: In what type of service is the truck being used?
5. Ask: Has this particular failure occurred before?
6. Ask: How was the truck working prior to the failure? You need to be a good listener. Sometimes, insignificant or unrelated symptoms can point to the cause of the failure:
7. Ask: Was the vehicle operating at normal temperatures?
8. Ask: Were the gauges showing normal ranges of operation?
9. Ask: Was there any unusual noise or vibration?

After listening, review the previous repair and maintenance records. If there is more than one driver, talk to all of them and compare their observations for consistency with the service and maintenance records. Verify the chassis Vehicle Identification Number (VIN) number from the vehicle identification plate, as well as the mileage and hours on the vehicle.

### Make a Preliminary Investigation

These steps consist of external inspections and observations that will be valuable when combined with the results of the parts examination.

1. Look for leaks, cracks or other damage that can point to the cause of the failure.
2. Make note of obvious leaks around plugs and seals. A missing fill or drain plug would be an obvious cause for concern.
3. Look for cracks in the carrier housing (harder to see, but sometimes visible).
4. Does the general mechanical condition of the vehicle indicate proper maintenance or are there signs of neglect?
5. Are the tires in good condition and do the sizes match?
6. If equipped with a torque-limiting device, is it working properly? During the preliminary investigation, write down anything out of the ordinary for later reference. Items that appear insignificant now may take on more importance when the subassemblies are torn down.



## Prepare the Parts for Inspection

After the preliminary investigation, locate the failure and prepare the part for examination. In carrier failure analysis, it may be necessary to disassemble the unit.

7. When disassembling subassemblies and parts, do not clean the parts immediately since cleaning may destroy some of the evidence.
8. When tearing down the drive axle, do it in the recommended manner. Minimize any further damage to the unit.
9. Ask more questions when examining the interior of the carrier. Does the lubricant meet the manufacturer specifications regarding quality, quantity and viscosity? As soon as you have located the failed part, take time to analyze the data.

## Find the Cause of the Failure

Here begins the real challenge to determine the exact cause of the failure. Keep in mind that there is no benefit to replacing a failed part without determining the cause of the failure. For example, after examining a failed part and finding that the failure is caused by a lack of lubrication, you must determine if there was an external leak. Obviously, if there is an external leak, just replacing the failed gear is not going to correct the situation.

Another important consideration is to determine the specific type of failure which can be a valuable indicator for the cause of failure. The following pages show different types of failures and possible causes. Use this as a guide in determining types of failures and in correcting problems.

## Correct the Cause of the Problem

Once the cause of the problem has been determined, refer to the appropriate service manual to perform the repairs.

### Clean

10. Wash steel parts with ground or polished surfaces in solvent. There are many suitable commercial solvents available. Kerosene and diesel fuel are acceptable.

 **WARNING:** Gasoline is not an acceptable solvent because of its extreme combustibility. It is unsafe in the workshop environment.

11. Wash castings or other rough parts in solvent or clean in hot solution tanks using mild alkali solutions.

**Note:** If a hot solution tank is used, make sure parts are heated thoroughly before rinsing.

12. Rinse thoroughly to remove all traces of the cleaning solution.

13. Dry parts immediately with clean rags.

14. Oil parts.

- If parts are to be reused immediately: Lightly oil.
- If parts are to be stored: Coat with oil, wrap in corrosion resistant paper and store in a clean, dry place.

## Inspect Axle Housing

Axle housing inspection and repairs are limited to the following checks or repairs:

- Visually inspect axle housing for cracks, nicks and burrs on machined surfaces.
- Check carrier bolt holes and studs for foreign material.
- Replace damaged fasteners. Look for loose studs or cross threaded holes.

**⚠ CAUTION:** Any damage which affects the alignment or structural integrity of the housing requires housing replacement. Do not repair by bending or straightening. This process can affect the material's properties and cause it to fail completely under load.

- Check all seals and gaskets.

**Note:** Replace conventional gaskets with silicone rubber gasket compound (included in many repair kits). The compound provides a more effective seal against lube seepage and is easier to remove from mating surfaces when replacing parts.

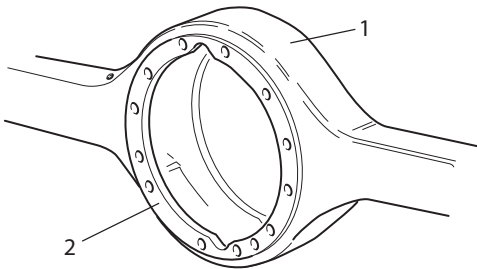

- 1 — Axle housing
- 2 — Machined surface

## Inspect Components

Inspect all steel parts for:

- Notches, visible steps or grooves created by wear
- Pitting or cracking along gear contact lines
- Scuffing, deformation or discolorations. These are signs of excessive heat in the axle and are usually related to low lubrication levels or improper lubrication practices.

In addition, inspect the following for damage:

- Differential gearing
- Bearings for loose fit on drive pinion, pilot bearing, and differential bearings
- All fasteners for rounded heads, bends, cracks or damaged threads.
- Inspect machined surfaces of cast or malleable parts. They must be free of nicks, burrs, cracks, scoring, and wear.
- Look for elongation of drilled holes, wear on surfaces machined for bearing fits and nicks or burrs in mating surfaces.

**Inspect Primary Gearing**

Before reusing a primary gear set, inspect teeth for signs of excessive wear. Check tooth contact pattern for evidence of incorrect adjustment.

**Check Input Shaft End-play (Forward Axle)**

**Note:** Before disassembling the power divider, measure and record input shaft end-play.

See illustration for steps 1-3.

1. Position dial indicator at yoke end of input shaft.
2. Push in on input shaft and zero the dial indicator.
3. Using a pry bar, move input shaft axially and measure/record end-play.

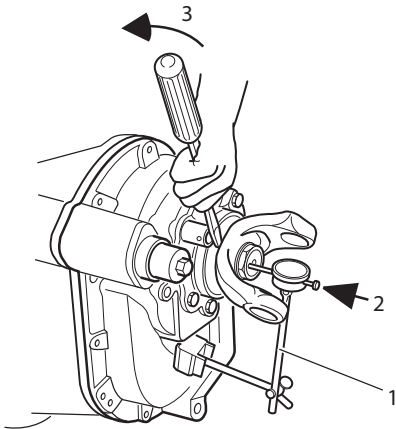

**Adjustment**

Correct end-play for a new assembly is 0.003” to 0.007”. The maximum end-play for a used assembly is no more than 0.014”. If end-play is incorrect, determine shim pack changes as follows:

**Add shims to increase end-play**

Desired end-play (New Parts)	0.003” to 0.007”
Measured end-play (Step 3)	0.001” – 0.001”
Add shims to provide desired end-play	0.002” to 0.006”

**Remove shim to decrease end-play**

Measured end-play (Step 3)	0.015” – 0.015”
Desired end-play (New Parts)	0.003” to 0.007”
Remove shims to provide desired end-play	0.012” to 0.008”

**Check Output Shaft End-play (Forward Axle)**

See illustration for steps 1-3.

1. Position dial indicator at yoke end of output shaft.
2. Push in on output shaft and zero the dial indicator.
3. Using a pry bar, move input shaft axially and measure/record end-play.

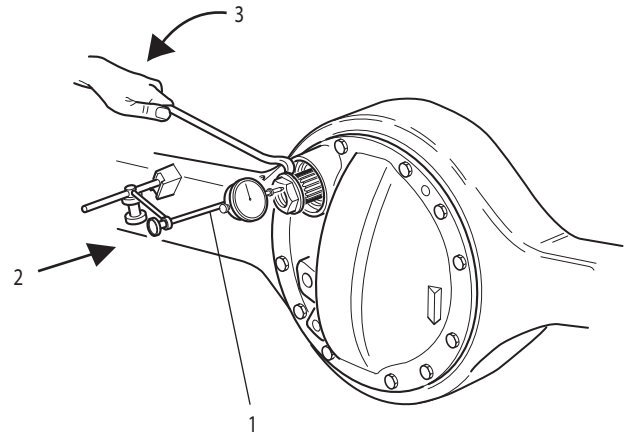

**Adjustment**

Correct end-play for a new assembly is 0.001” to 0.005”. The maximum end-play for a used assembly is no more than 0.005”. If end-play is incorrect, contact Dana.

Tandem Axle

Tandem Axle Assemblies

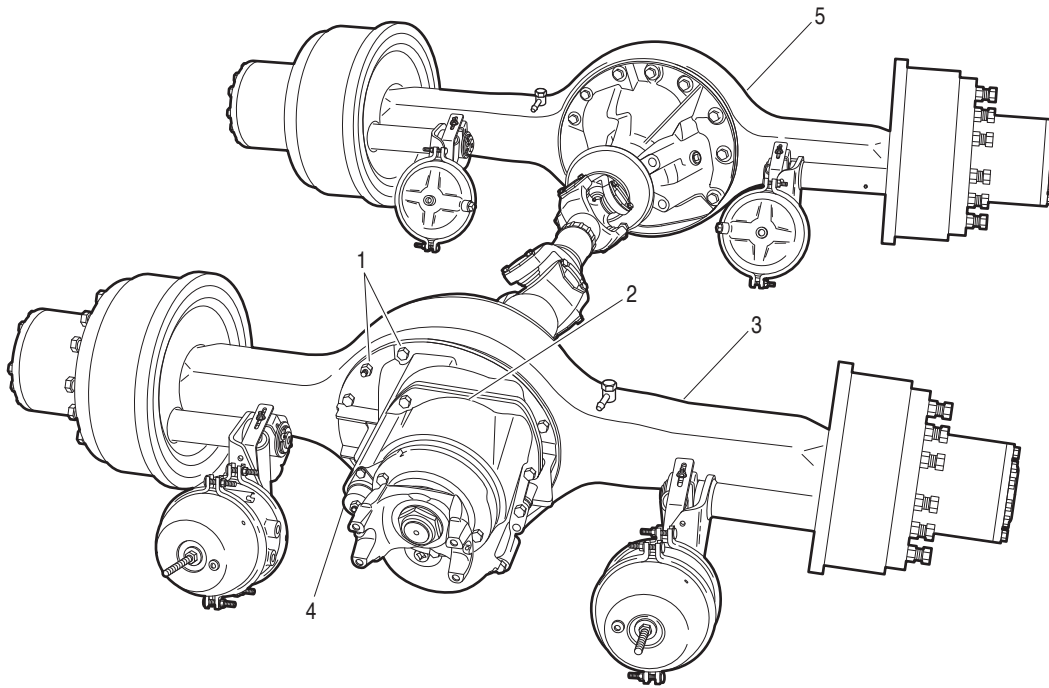

- 1 — Carrier fasteners
- 2 — Carrier assembly
- 3 — Front axle assembly

- 4 — Rear axle assembly
- 5 — Inter-axle differential lockout

## Forward Assembly

### Differential Carrier Assembly - Forward

#### Disassemble Carrier - Forward

**Note:** The removal of the forward carrier does not require disconnecting of the inter-axle driveline and removal of the output shaft yoke assembly as most other Dana tandems require.

#### Standard Differentials

1. Block the vehicle.
2. Drain axle lubricant.
3. Disconnect main driveline.
4. Disconnect differential lockout air line.
5. Disconnect lead wires to the selector switch and air line at shift cylinder.
6. Remove axle shafts.

#### Diff-Lock Models

For removal of the locking wheel differential carrier assembly, the differential lock must be engaged and held in the engaged position. This can be accomplished by one of two methods; either engage via air pressure or engage manually.

#### Engage via Air Pressure

- a. Using an auxiliary air line, apply 80–120 PSI air pressure to shift cylinder air port to engage clutch.

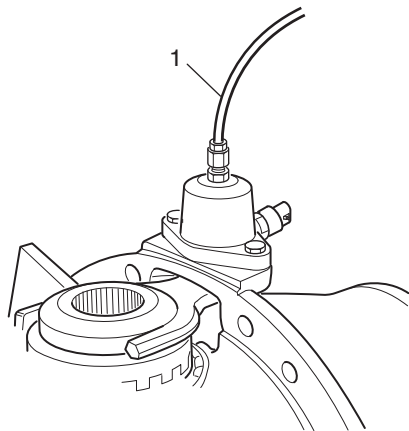

1 — Connect 80-120 PSI air line to cylinder port

#### Engage Manually

- a. Install a 0.250 – 18 NPTF bolt over 1.5” long in the cylinder air port to manually engage the clutches. GM models require a M12 X 1.5 X 38mm bolt.

**Note:** Hand-tighten the bolt, over-torquing may cause damage to the shift unit. To facilitate hand-tightening, coat bolt threads with axle lube.

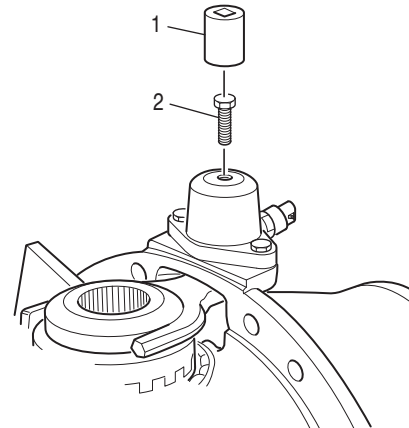

- 1 — Hand tighten with socket
- 2 — M12 x 1.5 x 38mm bolt – GM only 0.250 – 18 NPTF – all models except GM

**Note:** With either method, the axle shaft may have to be rotated to permit the clutch to become engaged.

**WARNING:** Do not lie under carrier after fasteners are removed. Use transmission jack to support differential carrier assembly prior to loosening fasteners.

7. To remove axle shaft, remove axle stud nuts (If used, remove lock washers and taper dowels).
8. Remove axle shafts.

**Note:** All models in this publication use axle shafts with unequal lengths. Axle shafts may also be location specific with various wheel equipment. Do not misplace axle shafts from their intended location. Identify left and right shafts for reference during reassembly.

**TIP:** If necessary, loosen dowels by holding a brass drift in the center of the shaft head and striking drift a sharp blow with a hammer.

**CAUTION:** Do not strike the shaft head with a steel hammer. Do not use chisels or wedges to loosen shaft or dowels.

9. Remove carrier cap screws, nuts and lock washers.
10. Remove differential carrier assembly.

### Install Differential Carrier - Forward

**Note:** Before installing carrier assembly, inspect and thoroughly clean interior of axle housing using an appropriate solvent and clean rag.

1. Apply Dana approved RTV compound on axle housing mating surface as shown in the illustration. Completely remove all old gasket material prior to applying new material. Compound will set in 20 minutes. Install carrier before compound sets or reapply.

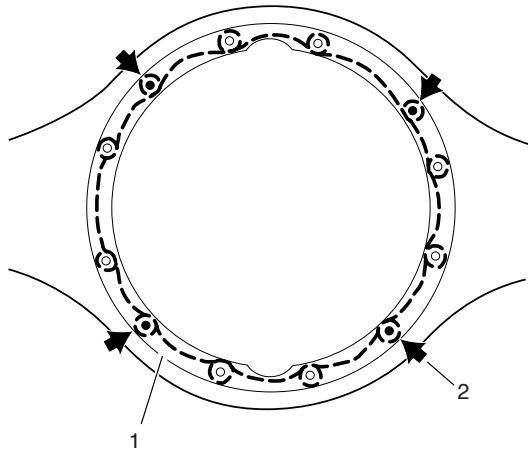

- 1 — Apply silicone gasket in this pattern  
 2 — Common stud locations

**TIP:** To assist in installing complete differential carrier use two pieces of threaded rod (M16 X 1.5) threaded into carrier cap screw holes. Rod should be approximately 6" long. Use these to pilot the carrier into the housing.

2. Install carrier to housing, lock washers, cap screws and nuts. Torque to proper specification. Torque to 230–270 lb-ft. (312–366 N•m).
3. After 11/02/98, axle housing covers are welded in place. If you have a bolt-on cover, install rear housing cover/output shaft assembly (see [page 52](#)). Torque all fasteners to proper specifications. Torque to 85–103 lb-ft. (115–140 N•m). Install inter-axle driveline making sure yokes are in phase.
4. Install axle shafts and axle stud nuts (if used, also install lock washers and tapered dowels).
5. Add axle lubricant. Fill to bottom of filler hole.
6. Connect main driveline, making sure all yokes are in phase. Lubricate U-joints.
7. Connect differential lockout air line.

## Inter-Axle Lockout Types - Forward

### Parts Exploded View

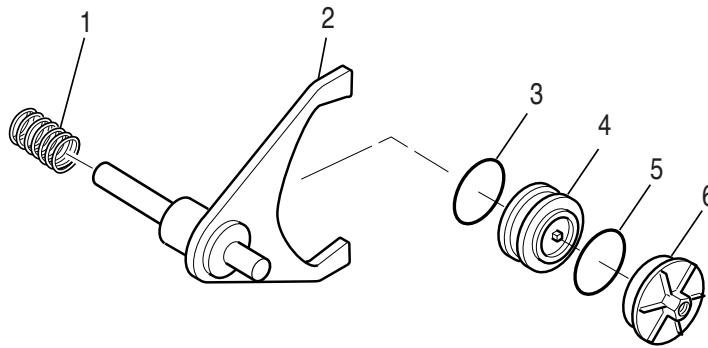

- |                               |                         |
|-------------------------------|-------------------------|
| <b>1</b> — Compression spring | <b>4</b> — Piston       |
| <b>2</b> — Shift fork         | <b>5</b> — O-ring       |
| <b>3</b> — O-ring             | <b>6</b> — Piston Cover |

Air-operated to engage the lockout and spring-released to disengage the lockout.

## Disassemble Lockout

### External Type Lockout

8. With axle installed in vehicle, place differential lock selector valve in the disengaged (or unlocked) position.
9. Disconnect differential lockout air line.
10. Remove cap screws.
11. Remove shift cylinder body or cast iron cover, o-ring and piston.

 **IMPORTANT:** Do not remove push rod. Removal of push rod will result in shift fork and compression spring falling into power divider unit. If this occurs, disassembly of the power divider assembly will be necessary.

12. Remove shoulder washer in cylindrical design lock-outs. Cast iron cover lockout designs do not use a shoulder washer.

**Note:** Cylindrical design lockout and cast iron cover lockout are interchangeable only as complete assemblies.

### Integral Type Lockout

1. With axle installed in vehicle, place differential lock selector valve in the disengaged (or unlocked) position.
2. Disconnect differential lockout air line.
3. Remove piston cover and o-ring.
4. Remove piston and o-ring assembly with pliers.

**Note:** To remove shift fork and push rod parts, the power divider must be removed. See power divider section.

## Install Lockout

### External Type Lockout

1. Assemble o-rings onto piston. Apply silicone grease to o-ring.
2. Install piston and o-ring assembly into cylinder body or cast iron cover.
3. Attach shift cylinder body or cast iron cover to power divider while aligning piston with push rod. Make sure shoulder washer or gasket is in place.
4. For stamped steel style lockouts, attach mounting bracket to cylinder body and secure cap screws.
5. Tighten cap screws to 28–35 lb-ft. (38–47 N•m).
6. Connect differential lockout air line.
7. Cycle the lockout unit to ensure there are no leaks and system shifts freely.

### Integral Type Lockout

1. Assemble o-rings onto piston and piston cover. Apply silicone grease to o-rings.
2. Gently push piston and o-ring assembly into lockout cylinder recess. Make sure piston is pushed all the way in.
3. Install piston cover and o-ring assembly. Start by hand tightening clockwise. Do not strip threads or use excessive force, damage to part may occur.
4. Tighten piston cover to 25-35 lb-ft. (35-47 N•m).
5. Connect differential lockout air line.
6. Cycle the lockout unit to make sure there are no leaks and the system shifts freely.



Power Divider - Forward

Parts Exploded View

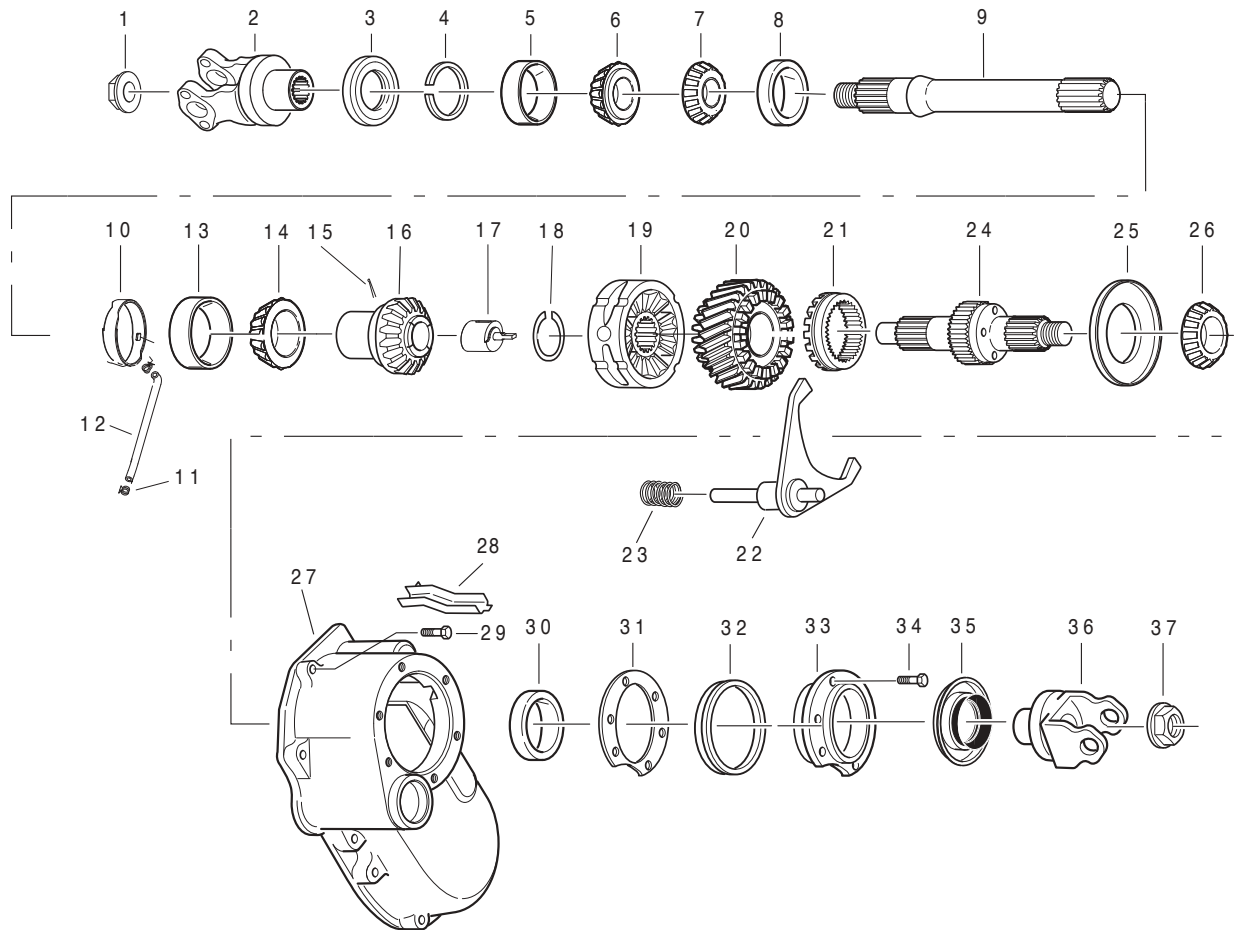

- |                                    |                                    |                          |
|------------------------------------|------------------------------------|--------------------------|
| 1 — Output shaft nut               | 14 — Output side gear bearing cone | 27 — Power divider cover |
| 2 — Output yoke                    | 15 — Pump locking pin              | 28 — Lube trough         |
| 3 — Output seal                    | 16 — Output side gear              | 29 — Cap screw           |
| 4 — Output shaft bearing snap ring | 17 — Pump                          | 30 — Input bearing cup   |
| 5 — Outer bearing cup              | 18 — Snapping ring                 | 31 — Input cage shim     |
| 6 — Outer bearing cone             | 19 — Inter-axle differential       | 32 — Input cage V-ring   |
| 7 — Inner bearing cone             | 20 — Helical side gear             | 33 — Input cage          |
| 8 — Inner bearing cup              | 21 — Sliding clutch                | 34 — Cap screw           |
| 9 — Output shaft                   | 22 — Shift fork assembly           | 35 — Oil Seal            |
| 10 — Seal manifold assembly        | 23 — Spring                        | 36 — Input yoke          |
| 11 — Sump screen                   | 24 — Input shaft                   | 37 — Input nut           |
| 12 — Seal manifold feed tube       | 25 — Input shaft oil retainer      |                          |
| 13 — Output side gear bearing cup  | 26 — Input shaft bearing cone      |                          |

**Disassemble, Assemble and Overhaul Power Divider - In Vehicle**

The power divider cover comes off as a unit followed by the input shaft and then the helical side gear.

The power divider can be replaced with the axle assembly both in or out of the chassis and with the differential carrier assembled to the axle housing.

During removal of power divider cover, the inter-axle differential (IAD), input shaft assembly or IAD shift system parts may fall from the carrier if not careful. Use caution to pre-vent injury or damage.

7. Disconnect the main driveline.

8. Disconnect the lockout air line.

9. Remove input yoke.

10. Remove input seal.

11. Position a drain pan under the power divider unit.

12. Remove PDU cap screws.

13. Remove power divider cover.

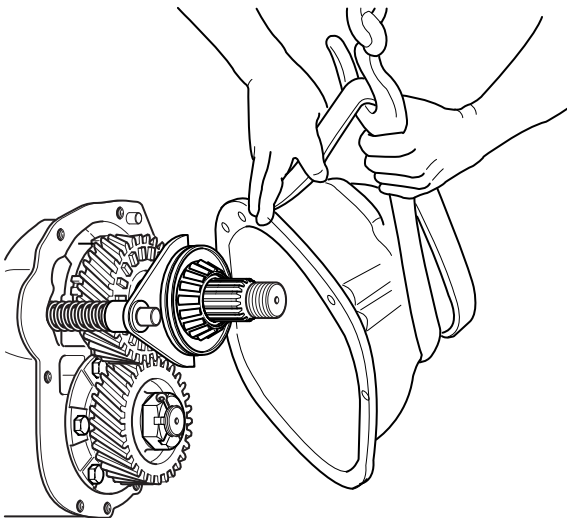

14. Remove shift fork, compression spring and shift rod.

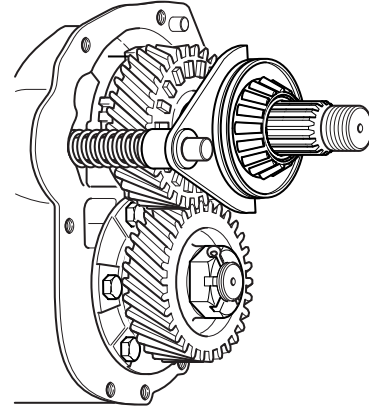

15. Remove input shaft drive assembly from the carrier.

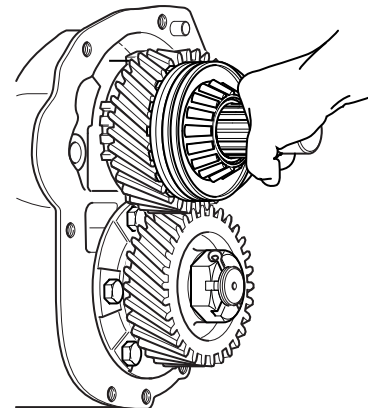

16. Remove the IAD assembly from the output side gear.

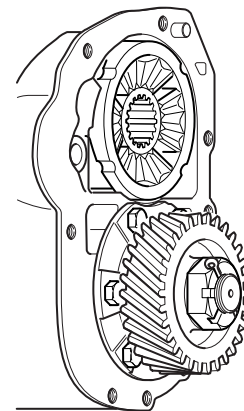

17. Remove helical side gear and snap ring.

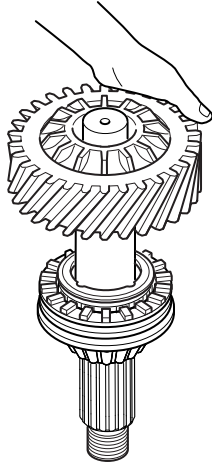

18. Remove thrust washer.

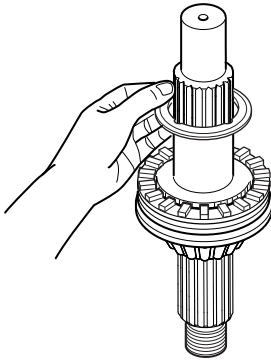

19. Remove lockout sliding clutch from the input shaft.

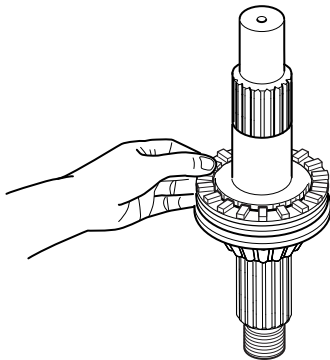

20. Remove the output side gear.

**Note:** Remove lube pump if you have one. See [page 29](#).

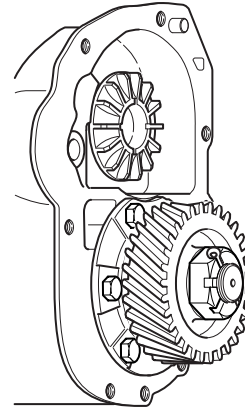

21. Inspect output side gear o-rings for nicks and cuts. Replace if necessary.

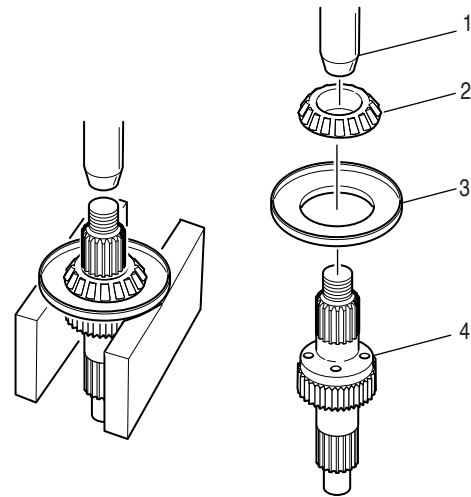

- 1 — Press
- 2 — Bearing
- 3 — Oil retainer
- 4 — Input shaft

22. Install new bearing cup.

23. Remove input shaft bearing cone and oil retainer, if necessary.

24. Press new oil retainer on input shaft.

**⚠ CAUTION:** It is not recommended to reuse the oil retainer due to possible damage that may occur while removing the input shaft bearing cone. While pressing on new oil retainer, make sure not to over press, and/or press with the retainer at an angle. If the retainer is bent or distorted it may rub on the input cage or not seal properly to the v-ring.

25. Press input bearing cone on input shaft.

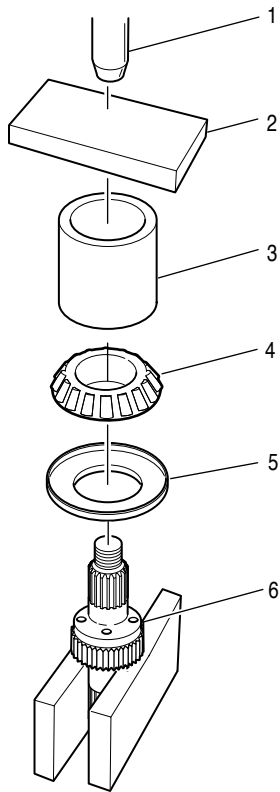

- |                  |                              |
|------------------|------------------------------|
| 1 — Press        | 4 — Input shaft bearing cone |
| 2 — Plate        | 5 — Oil retainer             |
| 3 — Drive sleeve | 6 — Input shaft              |

26. If input shaft bearing cup needs replacement, use either of the following recommended practices:

- Weld a bead around the cup, when the weld cools the cup will fall out.
- Drill a 1/4 size hole through the bearing cover to the back side of the cup and use a punch to remove the bearing cup.

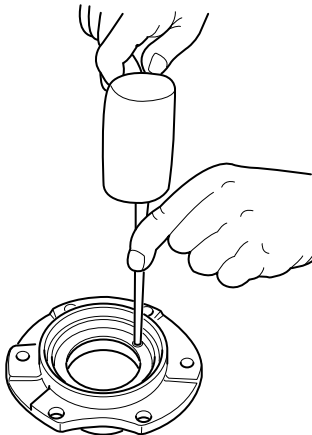

27. Press bearing cup in input bearing cover.

28. Install new oil v-ring on input bearing cage cover.

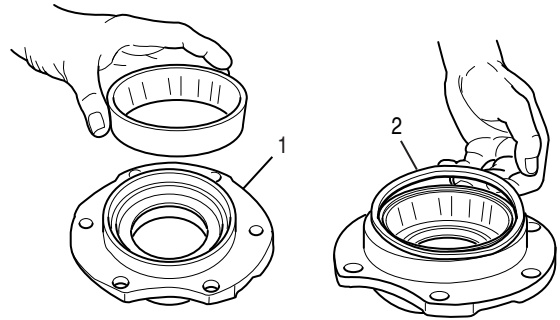

- |                         |
|-------------------------|
| 1 — Bearing cup (press) |
| 2 — V-ring              |

29. If bushing removal is needed, the bushings must exit from the thrust washer side of the helical gear.

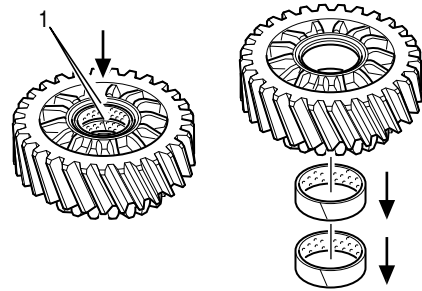

1 — Tap out bronze bushings

30. Install bronze bushing in helical side gear. **Bushings must be installed from thrust washer side of gear.** See illustration for dimensional tolerances.

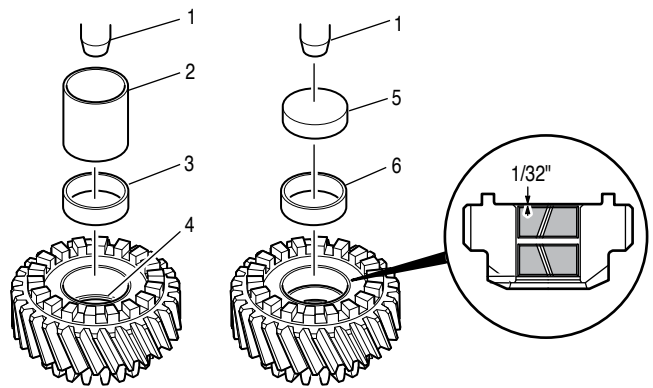

- |   |   |
|---|---|
| 1 — Press                                     | 4 — Shoulder                                |
| 2 — Sleeve                                    | 5 — Sleeve                                  |
| 3 — 1st bronze bushing<br>(press to shoulder) | 6 — Second bronze bushing<br>(recess 1/32") |

**Install Power Divider to Carrier Assembly - In Vehicle**

**Note:** See [page 19](#) for out of vehicle.

**Note:** Parts inspection and cleaning procedures are important and should be adhered to. Cleanliness in your work area is important as dirt is an abrasive and will cause premature wear of the otherwise serviceable parts.

**CAUTION:** During installation of power divider components, the inter-axle differential, input shaft assembly or IAD shift system parts may fall from the carrier if not careful. Use caution to prevent injury or damage.

1. Make sure dowel pins are installed in carrier.
2. Install output side gear bearing cup, if removed. Press bearing cup in carrier. Use a press and an appropriate sleeve. Make certain bearing cup is evenly and firmly seated. If a press is not available, use a sleeve or a bearing driver tool and a hammer to install the cup.

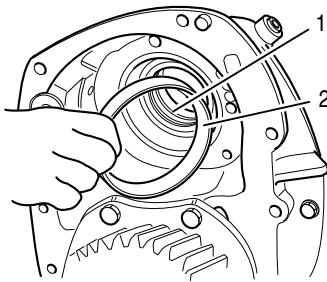

- 1 — Lubricate o-rings
- 2 — Bearing cup

3. Lubricate o-rings.
4. Install the output side gear, if removed.

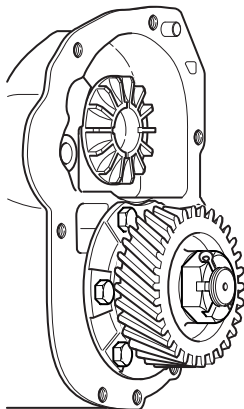

5. Install the IAD assembly to the output side gear. If reusing the IAD assembly, install in the same direction as removed.

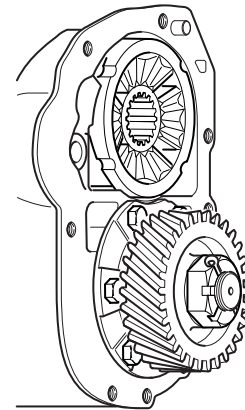

**Note:** For lube pump models, see [page 22](#).

6. Out of the vehicle—on a bench, install lockout sliding clutch onto the input shaft.

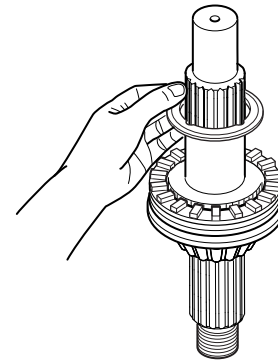

7. Install thrust washer.

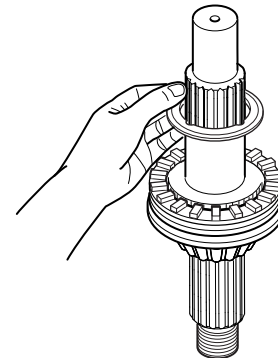

8. Install helical side gear and snap ring.

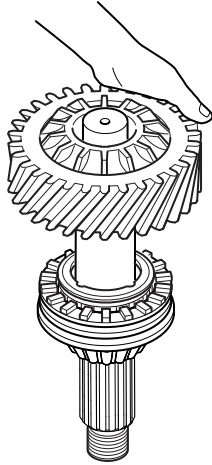

9. Install input shaft drive assembly into the carrier.

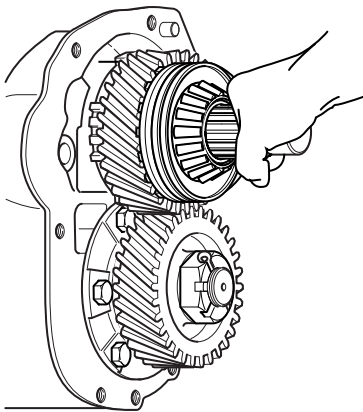

10. Install shift fork, compression spring and shift rod.

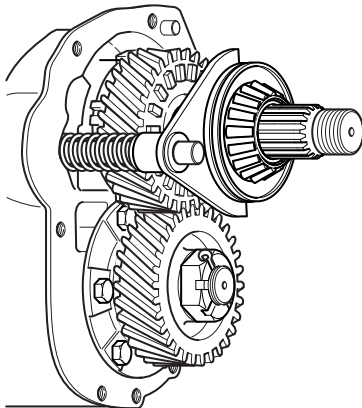

**⚠ CAUTION:** During installation of power divider components, a part may fall from the carrier. Use caution to prevent injury or damage.

11. Install plastic trough in power divider cover.

12. Install power divider cover to carrier. Use Dana approved RTV compound on the carrier mating surface. Torque cap screws to 114–140 lb-ft. (155–190 N•m).

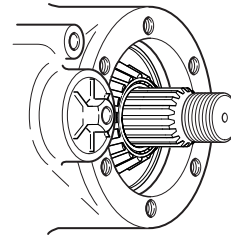

**Note:** Gasket compound will harden in 20 minutes. Install power divider quickly as possible to avoid future leaks.

13. Install input cage shim and input cage assembly.

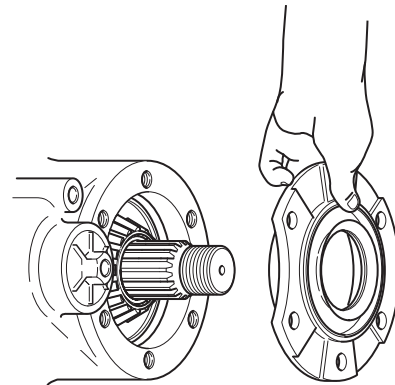
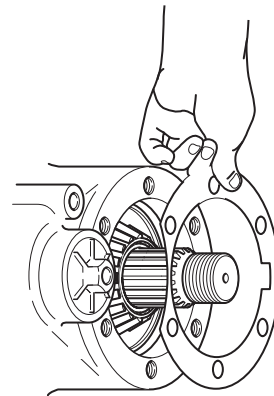

14. Install input cage cap screws and tighten until snug.

15. Measure and adjust input shaft end-play, see [page 27](#).

16. Torque input cage cap screws to 114–140 lb-ft. (155–190 N•m).

17. Install NEW input seal.

18. Reinstall input yoke.

## Disassemble, Assemble and Overhaul Power Divider - Out of Vehicle

The power divider cover comes off as a unit followed by the input shaft and then the helical side gear.

The power divider can be replaced with the axle assembly both in or out of the chassis and with the differential carrier assembled to the axle housing.

**CAUTION:** During removal of power divider cover, the inter-axle differential (IAD), input shaft assembly or IAD shift system parts may fall from the carrier if not careful. Use caution to prevent injury or damage.

1. Disconnect the main driveline.
2. Disconnect the lockout air line.
3. Remove input yoke.
4. Remove input seal.
5. Position a drain pan under the power divider unit.
6. Remove PDU cap screws.
7. Remove power divider cover.

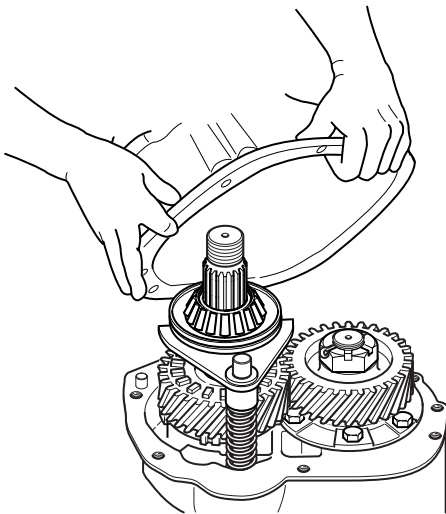

8. Remove shift fork, compression spring and shift rod.

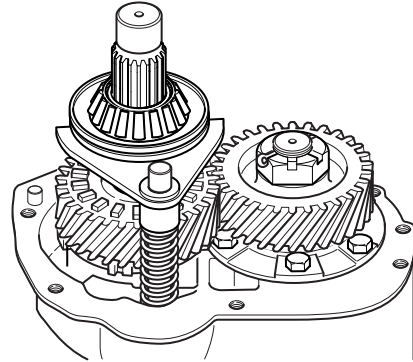

9. Remove input shaft and helical thrust washer from the carrier.

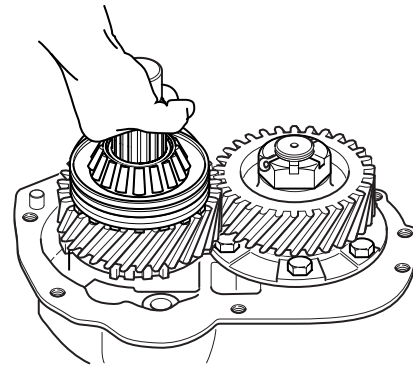

10. Remove helical side gear.

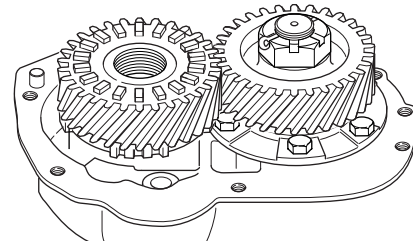

11. Remove the IAD assembly from the output side gear.

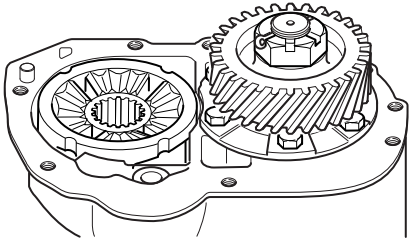

12. Remove the output side gear.

**Note:** Remove lube pump if you have one.

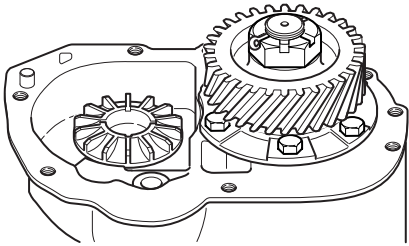

13. Inspect output side gear o-rings for nicks and cuts. Replace if necessary.

14. Install new bearing cup.

15. Remove input shaft bearing cone and oil retainer, if necessary.

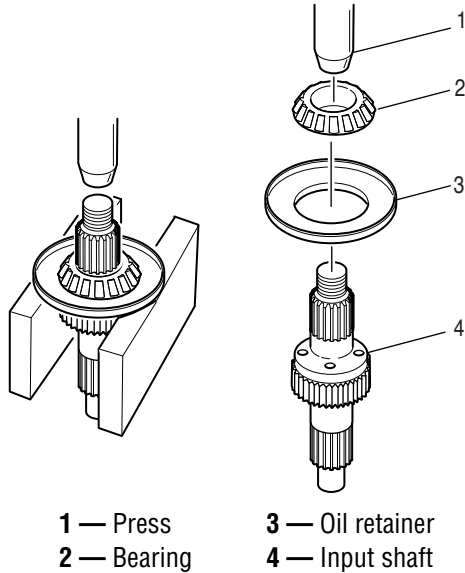

16. Press new oil retainer on input shaft.

**CAUTION:** It is not recommended to reuse the oil retainer due to possible damage that may occur while removing the input shaft bearing cone. While pressing on new oil retainer, make sure not to over press, and/or press with the retainer at an angle. If the retainer is bent or distorted it may rub on the input cage or not seal properly to the v-ring.

17. Press input bearing cone on input shaft.

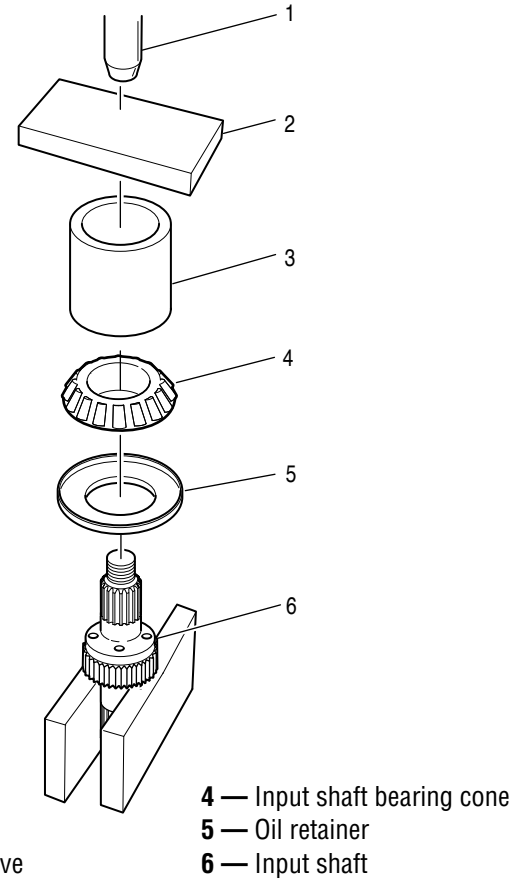



18. If input shaft bearing cup needs replacement, use either of the following recommended practices:

- Weld a bead around the cup, when the weld cools the cup will fall out.
- Drill a 1/4 size hole through the bearing cover to the back side of the cup and use a punch to remove the bearing cup.

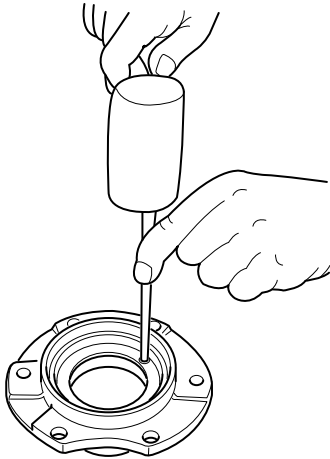

19. Press bearing cup in input bearing cover.

20. Install new oil v-ring on input bearing cage cover.

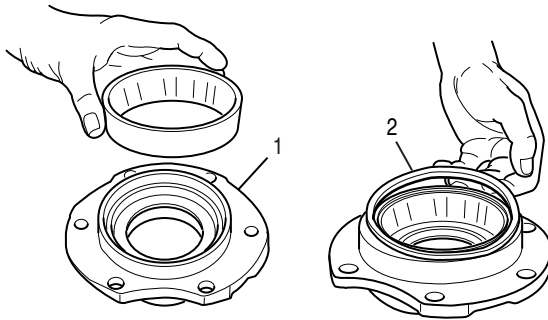

- 1 — Bearing cup (press)
- 2 — V-ring

21. If bushing removal is needed, the bushings must exit from the thrust washer side of the helical gear.

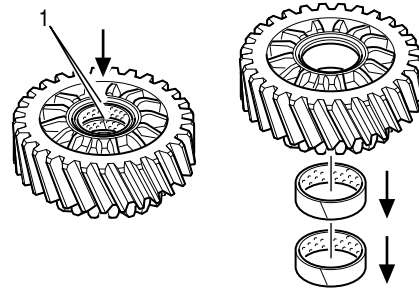

1 — Tap out bronze bushings

22. Install bronze bushing in helical side gear. Bushings must be installed from thrust washer side of gear. See illustration for dimensional tolerances.

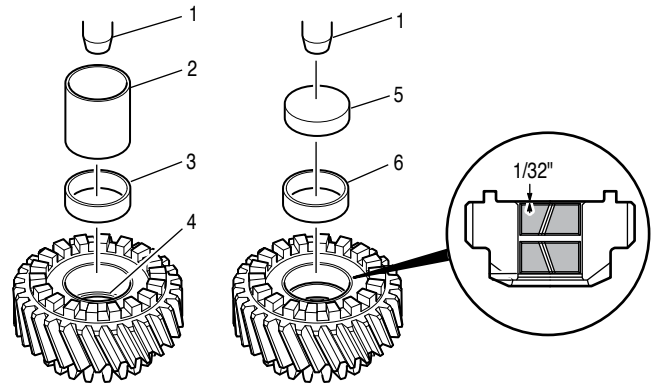

- 1 — Press
- 2 — Sleeve
- 3 — 1st bronze bushing (press to shoulder)
- 4 — Shoulder
- 5 — Sleeve
- 6 — Second bronze bushing (recess 1/32")

## Install Power Divider to Carrier Assembly - Out of Vehicle

**Note:** Parts inspection and cleaning procedures are important and should be adhered to. Cleanliness in your work area is important as dirt is an abrasive and will cause premature wear of the otherwise serviceable parts.

**Note:** It is assumed that the different carrier is secured in a stand.

**CAUTION:** During installation of power divider components, parts may fall from the carrier if not careful. Use caution to prevent injury or damage.

1. Make sure dowel pins are installed in carrier.
2. Output side gear bearing cup. If removed, press bearing cup in carrier. Use a press and an appropriate sleeve. Make certain bearing cup is evenly and firmly seated. If a press is not available, use a sleeve or a bearing driver tool and a hammer to install the cup.
3. Lubricate o-rings.
4. Install the output side gear using one of the following instructions (non-pump models or lube pump models).

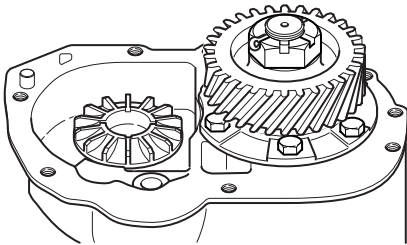

### Non-pump Models

- a. Install output side gear.
- b. Install the IAD assembly to the output side gear. If reusing the IAD assembly, install the same direction as removed.

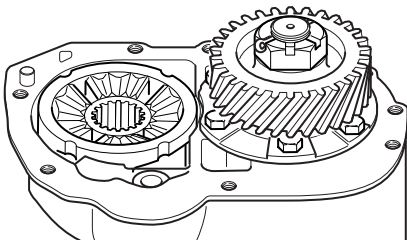

### Lube Pump Models

- a. Install output side gear/pump assembly into carrier. The lube pump mounting holes are oriented in such a way that it can be installed only in one position.
  - b. Lube pump coupling—Line up the drive couplings tangs with the pump and IAD notches. The spacing of the tangs are the same, one side to the other. If reusing the IAD assembly, install the same direction as it was removed.
5. Install helical side gear.

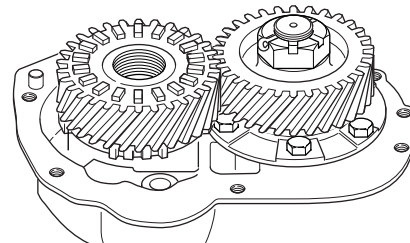

6. Install thrust washer.

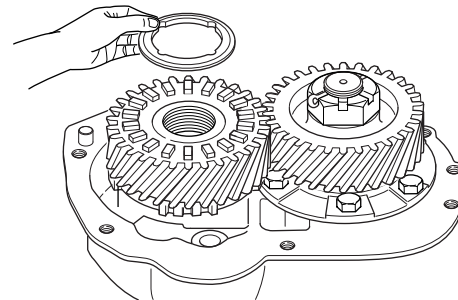

7. Install compression spring, shift fork, push rod and lockout sliding clutch.

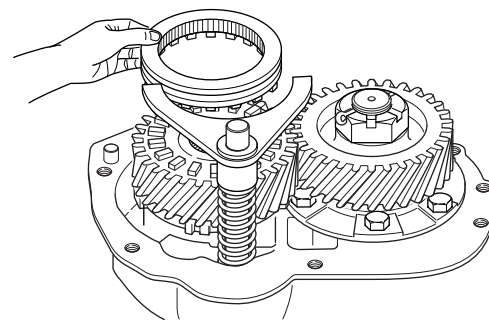

8. Install input shaft assembly.

**Note:** The input shaft snap ring is not used in this buildup.

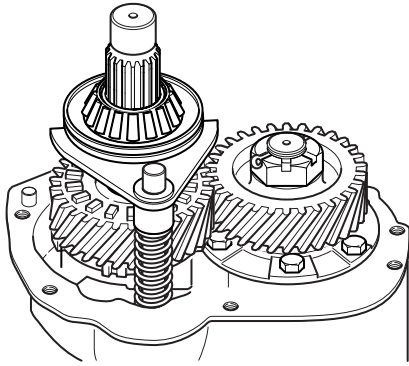

**9.** Install plastic oil trough in power divider cover.

**10.** Install power divider cover to carrier. Use Dana approved RTV compound on the carrier mating surface. Torque cap screws to 114–140 lb-ft. (155–190 N•m).

**Note:** Gasket compound will harden in 20 minutes. Install power divider as quickly as possible to avoid future leaks.

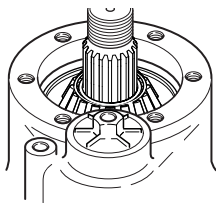

**11.** Install input cage shim and input cage assembly.

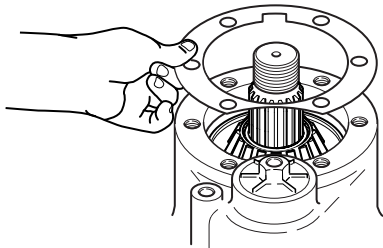

**12.** Install input cage cap screws and tighten until snug.

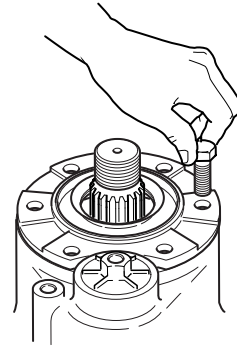

**13.** Measure and adjust input shaft end-play, see [page 27](#).

**14.** Torque input cage cap screws to 114–140 lb-ft. (155–190 N•m)

**15.** Install NEW input seal.

**16.** Reinstall input yoke.

### Lube Pump Disassembly

For output side gear and/or pump replacement, follow the procedure below.

1. Remove the output side gear bearing cone, if required.

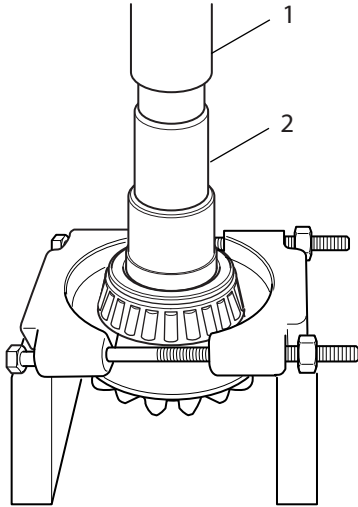

- 1 — Press
- 2 — Press tool

2. Remove pump locking dowel pin from the hole in the output side gear hub.

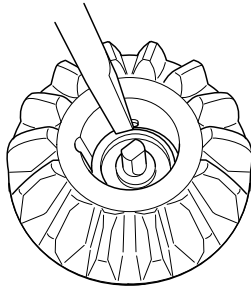

3. Remove pump from the output side gear.

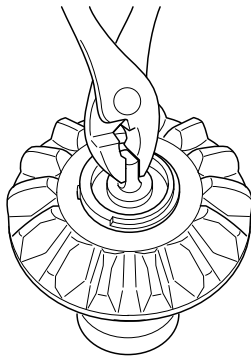

### Lube Pump Installation

Use these instructions with the carrier assembly in or out of the vehicle. If the unit does not have a pump, go to the Power Divider Assembly section.

**Note:** Keep work area clean. Dirt is an abrasive and will cause premature wear of the otherwise serviceable parts.

**Note:** For non-pump models, see [page 16](#) for output side gear seal manifold installation.

**Note:** Only service the power divider if the differential carrier is secured in a stand or while the axle is still attached to the housing.

**CAUTION:** During installation of power divider cover, the inter-axle differential (IAD), input shaft assembly or IAD shift system parts may fall from the carrier if not careful. Use caution to prevent injury or damage.

1. Install the pump into the output side gear so that the pump shaft is facing toward the teeth end of the side gear.

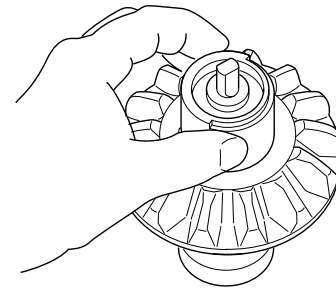

2. Install the pump locking dowel pin into the hole in the output side gear hub. Make sure the pin is lined up with the machined slot in the pump body.

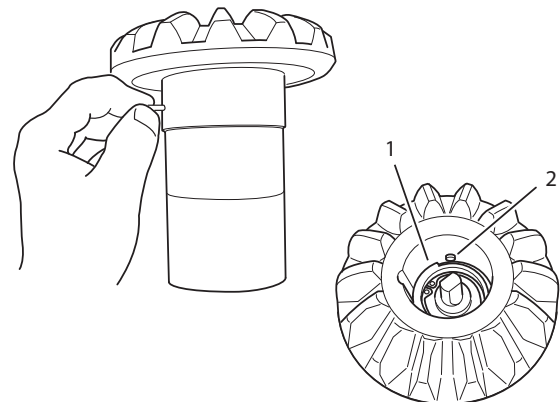

- 1 — Machined slot
- 2 — Pin

### Lube Manifold Disassembly

1. Disconnect the hose from the lube manifold.
2. Remove the manifold assembly by prying it out around the inner diameter.

**⚠ IMPORTANT:** Once removed, the seal manifold assembly cannot be reused. This component should always be replaced with new. Use the same removal procedure for the output side gear seal removal on the non-pump models.

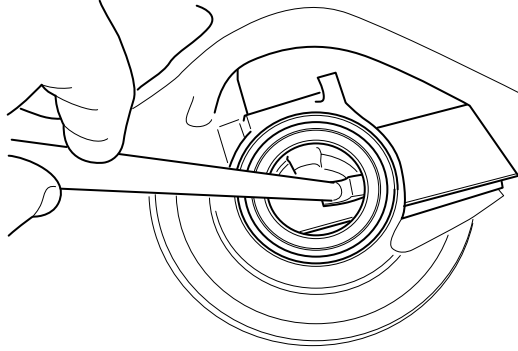

**Note:** Seals are not sold separately from the manifold.

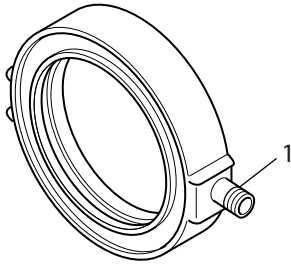

1 — Barbed nipple

### Lube Manifold Installation

1. Install the manifold assembly into the output side gear bore in the carrier. Make sure the barbed nipple is lined up with the opening in the carrier casting.

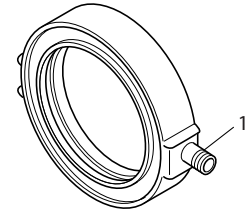
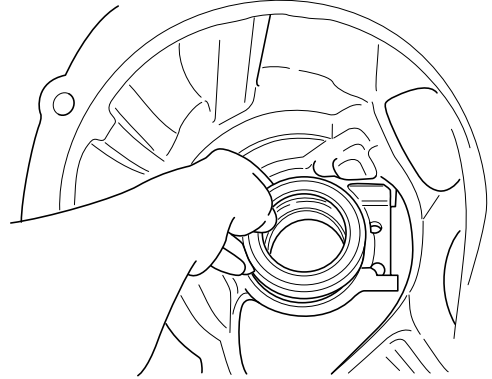

1 — Barbed nipple

2. Install the hose clamp on the hose, push the hose onto the barbed fitting and slide the clamp over the barbed nipple.
3. Route the suction end of the hose through the holes in the carrier casting to the bottom of the carrier.

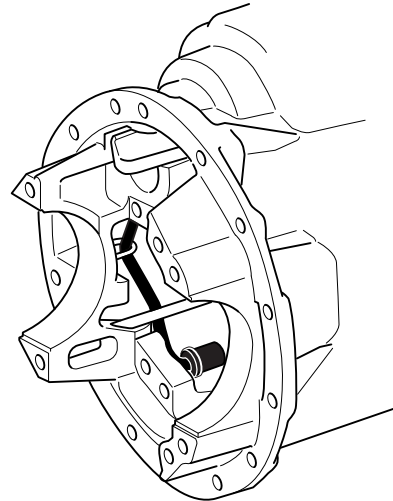

4. Fully press the manifold assembly into position.

**Note:** Use care when pressing the manifold assembly to avoid damaging the seals and barbed nipple. Do not over-press plastic.

**Note:** For non-pump manifold installation, it is important to line up the oil inlet path hole in the manifold with the oil path opening in the carrier manifold casting.

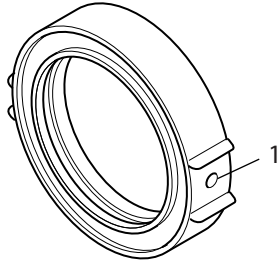

### Measure and Adjust Input Shaft End-Play

**Note:** After power divider overhaul and installation on carrier, check and adjust input shaft end-play. The correct end-play when new parts are used in overhaul is 0.003" to 0.007", with reused parts the maximum is 0.014".

1. Remove input shaft nut. Remove input bearing cover cap screws. Remove bearing cover (and shim pack if installed).
2. Reinstall bearing cover without shims. Hold in position with hand pressure and measure clearance between power divider cover and bearing cover, using a feeler gauge.

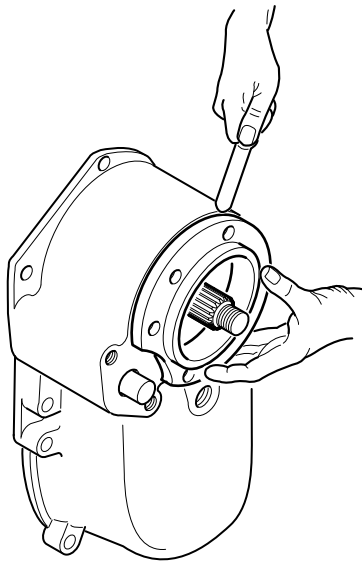

3. The bearing cover clearance measured in Step 2 plus 0.005" will equal shim pack thickness required for desired end-play (rebuild with new parts). Add 0.015" to shim pack for rebuild with used parts.

4. Install shim pack and bearing cover. Install cap screws. Torque screws to 114–140 lb-ft. (155–190 N•m). Make sure shims are flat with no kinks or bends.

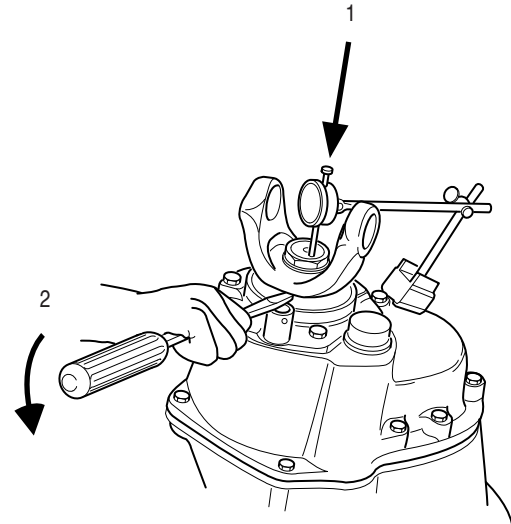

- 1 — Push in and zero indicator, read and record
- 2 — Pry down

5. Install yoke using installation tool and nut. Tighten nut snugly. Tap end of input shaft lightly to seat bearings.
6. Check input shaft end-play with dial indicator positioned at yoke end of input shaft. Move input shaft axially and measure end-play. If end-play is correct, seal shim pack with Dana approved RTV compound to prevent lube leakage. Then torque input shaft nut.
7. If end-play is incorrect, change shim pack size as follows:

#### Add shims to increase end-play

Desired end-play (New Parts)	0.003" to 0.007"
Measured end-play (Step 3)	0.001" – 0.001"
Add shims to provide desired end-play	0.002" to 0.006"

#### Remove shim to decrease end-play

Measured end-play (Step 3)	0.015" – 0.015"
Desired end-play (New Parts)	0.003" to 0.007"
Remove shims to provide desired end-play	0.012" to 0.008"

8. To add or remove shims, remove input shaft nut and yoke. Remove cap screws, lock washers and bearing cover. Add or remove shims as required.
9. Install bearing cover and cap screws. Seal shim pack with Dana approved RTV compound to prevent lube leakage then torque input shaft cap screws 150–165 lb-ft. (204–224 N•m).
10. Install yoke.
11. Install yoke nut. One of the following options may be used.
  - a. Install a new nut with the pre-applied thread adhesive compound. Tighten the nut to the specified torque 840–1020 lb-ft. (1148–1383 N•m).

If difficulty is experienced in achieving correct torque, torque the nut with the truck wheels on the ground and with the axle shaft installed.

**! IMPORTANT:** Follow the instructions specified by the thread adhesive manufacture when applying thread adhesive compound.

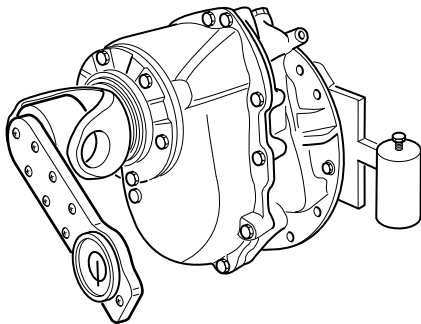

- b. If a new nut with pre-applied thread adhesive compound is unavailable, apply “Loctite 277” or “271” (available in 0.5 ml tube – Dana P/N 129293) to the nut along two threads, for at least two flats (120°) of the nut midway through the thickness. Tighten the nut to the specified torque 840–1020 lb-ft. (1148–1383 N•m).

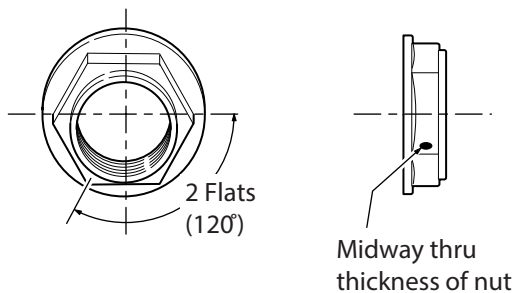

**Note:** Use of a torque multiplier is recommended.



Carrier Assembly - Forward

Parts Exploded View

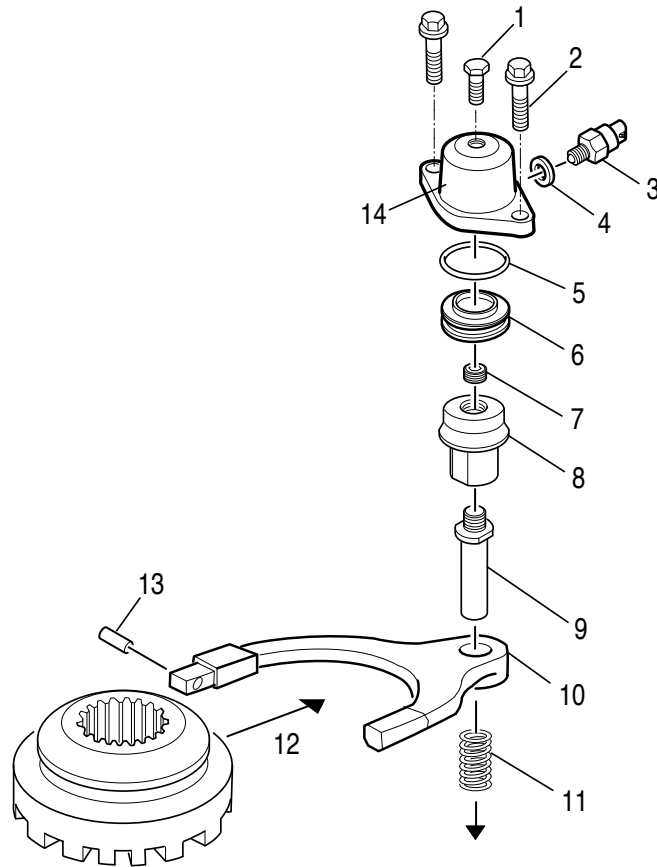

- |                                   |                            |
|-----------------------------------|----------------------------|
| <b>1</b> — Piston engagement bolt | <b>8</b> — Piston driver   |
| <b>2</b> — Cap screw              | <b>9</b> — Push rod        |
| <b>3</b> — Switch                 | <b>10</b> — Clutch fork    |
| <b>4</b> — Washer                 | <b>11</b> — Spring         |
| <b>5</b> — O-ring                 | <b>12</b> — Sliding clutch |
| <b>6</b> — Piston                 | <b>13</b> — Pin            |
| <b>7</b> — Setscrew               | <b>14</b> — Piston cover   |

## Disassemble Carrier Assembly

For models having the wheel differential lock option or a carrier thrust bolt follow the steps below. These parts must be removed first before further removal of the wheel differential can take place.

### Disassemble Wheel Differential – Models with Wheel Differential Lock

1. For ease of servicing, mount differential carrier in stand with differential lock facing up.

**Note:** To overhaul and reassemble the wheel differential, the shift fork and clutch assembly must be removed from carrier. See instructions below.

2. Remove shift cylinder mounting screws, then lift shift cylinder, piston and o-ring assembly off carrier and end of push rod.

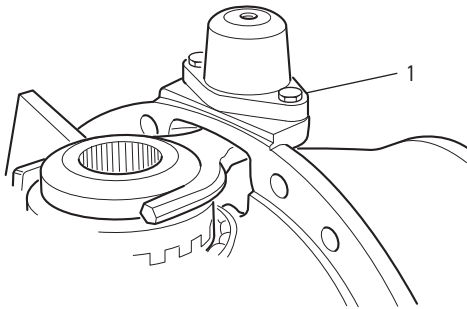

1 — Shift cylinder

3. To disassemble shift cylinder for inspection, first remove or back off actuator switch. The piston and o-ring assembly can be removed by inserting a pencil-size tool through the cylinder air port.

4. Grasp push rod end and pull it out of the shift fork, spring and carrier.

**Note:** When the push rod is disengaged from the shift fork, the fork and sliding curvic clutch assembly can be removed from carrier.

**Note:** Do not disassemble shift fork from the sliding curvic clutch unless parts replacement is necessary. To disassemble, use pin punch to remove spring pin from long leg of fork. The fork can now be disengaged from the clutch.

5. Remove the snap ring, then lift fixed curvic clutch off differential case hub spline. Further disassembly of carrier is the same for axles without differential lock.

## Models with Ring Gear Thrust Bolt

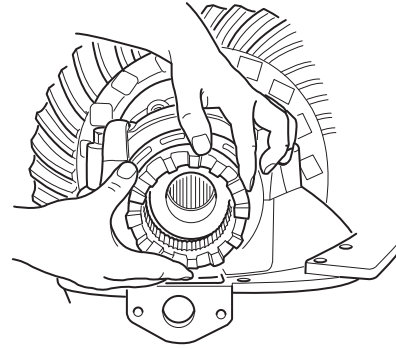

**Note:** If the carrier model has a ring gear thrust bolt installed, it must be backed away from the ring gear before you can remove the wheel differential.

1. Back off thrust bolt jam nut.
2. Back out thrust bolt from the carrier until the end of the bolt is flush with the inside of the carrier casting. This will allow enough clearance between the ring gear and the carrier pilot web.

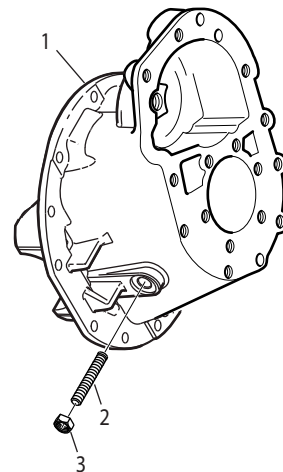

1 — D-head carrier or front carrier  
 2 — Thrust bolt  
 3 — Thrust bolt jam nut

**Disassemble Wheel Differential (All Standard Models)**

**Note:** Omit this step if the gear set is to be replaced. If gear set is to be reused, check tooth contact pattern and ring gear backlash before disassembling differential carrier. When checking backlash, a yoke or helical gear must be installed and torqued to get an accurate reading. Best results are obtained when established wear patterns are maintained in used gearing.

1. Mount differential carrier in repair stand.

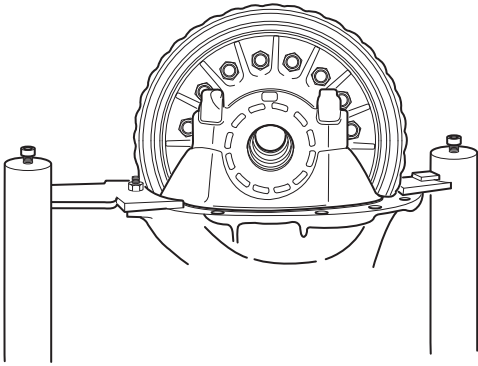

**Note:** For easier disassembly, loosen but do not remove pinion (self-locking) nut. Forward axle pinion is equipped with slotted nut, remove roll pin with a pin punch then loosen nut.

2. If reusing gear set, also punch mark bearing adjusters for reference during assembly.

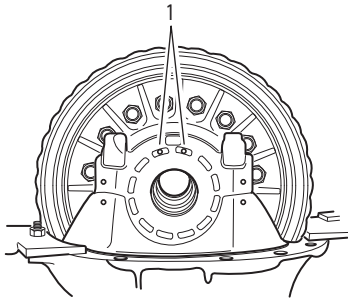

1 — Punch marks

3. Remove cap screws, flat washers and bearing caps. Back off bearing adjusters and remove adjusters and bearing cups.

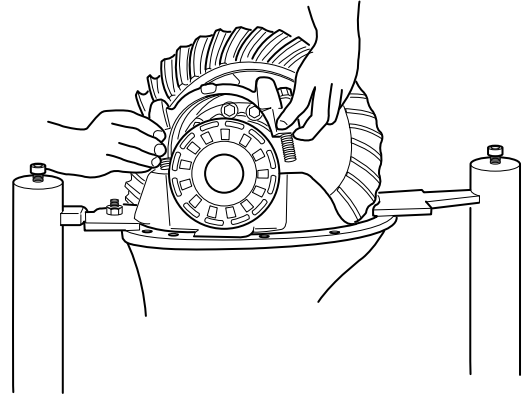

4. Using a chain hoist, lift ring gear and differential assembly out of carrier.

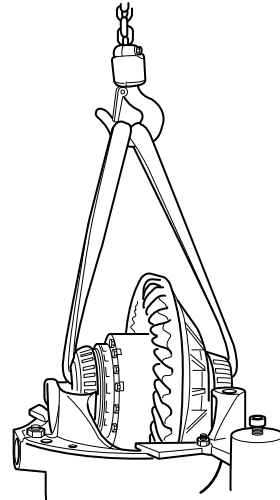

## Disassemble Pinion Assembly

1. Remove pinion bearing cage cap screws. Remove pinion and cage assembly from carrier. Remove shim pack.

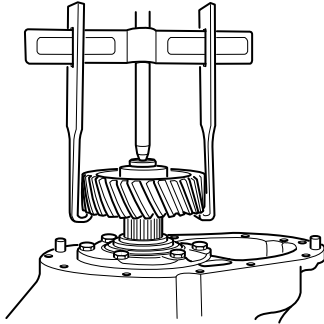

**Note:** For easier disassembly, loosen but do not remove pinion (self-locking) nut. Forward axle pinion is equipped with slotted nut, remove roll pin with a pin punch then loosen nut.

2. Remove pinion bearing cage cap screws. Remove pinion and cage assembly from carrier. Remove shim pack.

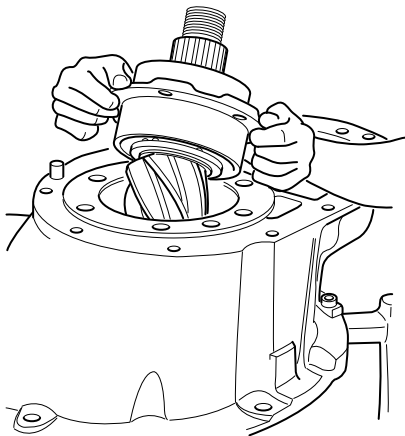

**⚠ IMPORTANT:** Do not allow pinion to drop on hard surface. If gear set is to be reused, keep pinion bearing cage shim pack intact for use in reassembly. If the original shims cannot be reused, record the number and size of shims in the pack.

Front Axle Pinion Assembly - Forward

Parts Exploded View

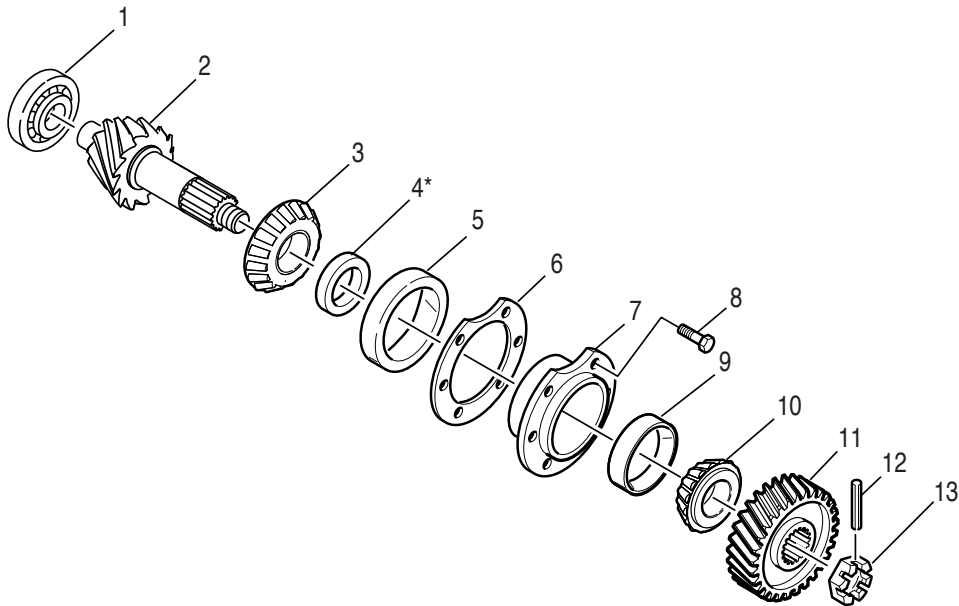

- |  |   |
|--|---|
| <b>1</b> — Pinion pilot bearing        | <b>8</b> — Cap screw                    |
| <b>2</b> — Pinion                      | <b>9</b> — Pinion bearing cup - outer   |
| <b>3</b> — Pinion bearing cone - inner | <b>10</b> — Pinion bearing cone - outer |
| <b>4</b> — Pinion bearing spacer*      | <b>11</b> — Pinion helical gear         |
| <b>5</b> — Pinion bearing cup - inner  | <b>12</b> — Roll pin                    |
| <b>6</b> — Shim                        | <b>13</b> — Slotted pinion nut*         |
| <b>7</b> — Pinion bearing cage         |   |

\* Before 3/01/95 two spacers were used instead of the one shown.

**Disassemble and Overhaul Drive Pinion**

The following procedures cover both forward and rear differential drive carrier disassembly.

- 3. Remove the pinion nut roll pin.
- 4. Loosen and remove the pinion nut.
- 5. Remove the helical gear with the proper puller tool.
- 6. Press pinion out of bearing cage and bearing cone.

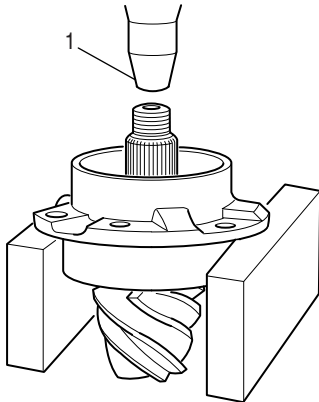

1 — Press ram

- 7. Remove bearing cups with proper puller tool.
- 8. Remove bearing spacer from pinion.

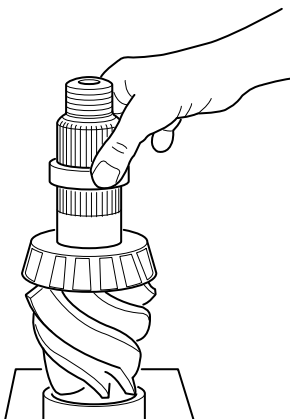

- 9. Remove pilot bearing from pinion using a split-type puller. Use two procedure steps to remove each bearing.
  - a. Mount puller vertically to separate the bearing. This action will force puller halves under bearing and start moving bearing off pinion.

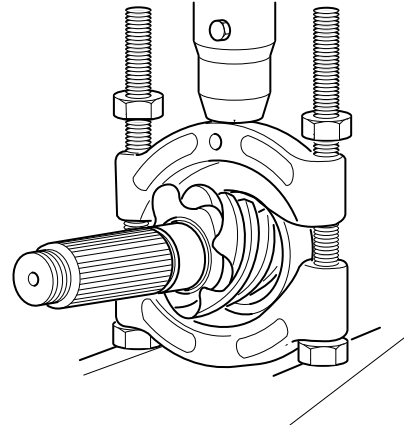

- b. Mount puller horizontally to press pinion out of bearing.

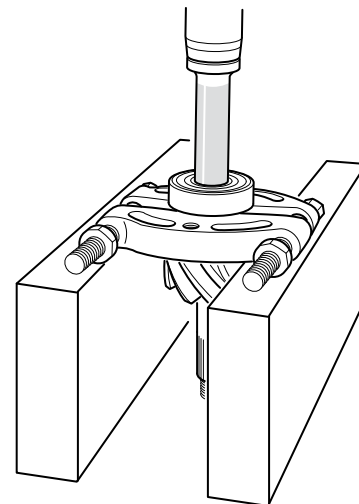

10. Remove inner bearing cone from pinion using a split-type puller. Use two procedure steps to remove each bearing.

a. Mount puller vertically to separate the bearing. This action will force puller halves under bearing and start moving bearing off pinion.

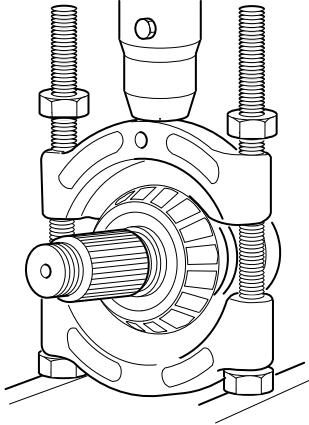

b. Mount puller horizontally to press pinion out of bearing.

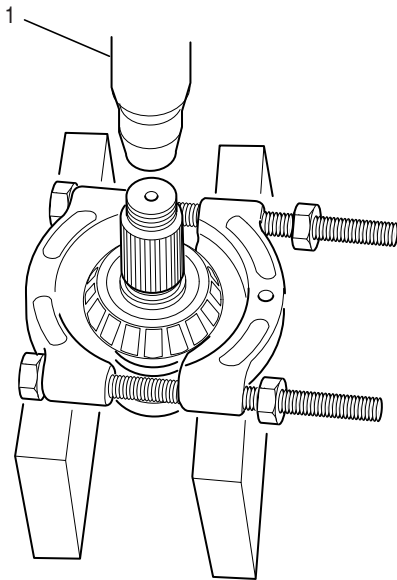

1 — Press

### Replace Pinion Bearing Cage Cups

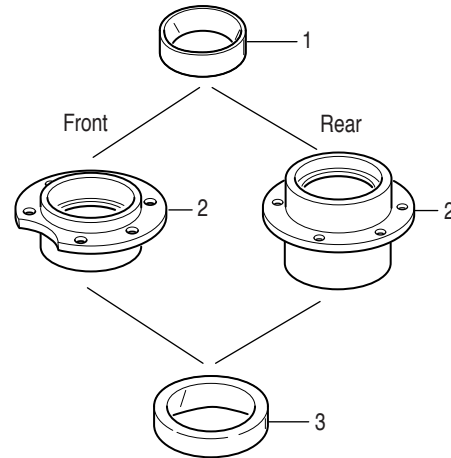

- 1 — Cup (outer)
- 2 — Bearing cage
- 3 — Cup (inner)

1. Remove cups.
2. Clean and inspect bearing cages for damage, nicks and burrs.

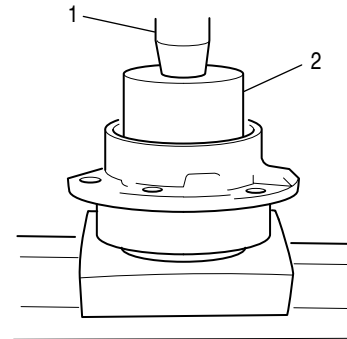

- 1 — Press ram
- 2 — Sleeve must apply pressure to back face of outer bearing cone

3. Install inner and outer pinion bearing cups. Use a press and an appropriate drive sleeve. Make certain bearing cup is evenly and firmly seated.

4. Seat cups securely to shoulder. Check clearance between cup and bearing cage. Must be less than 0.001".

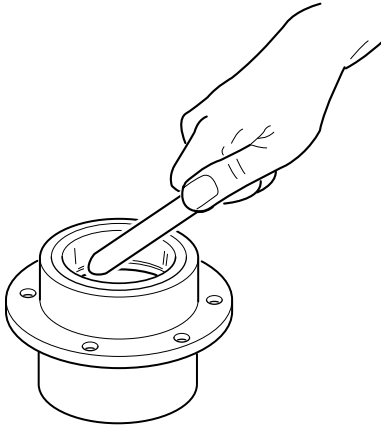

### Adjust Pinion Bearing Preload

#### Trial Buildup

1. Assemble pinion bearing cage, bearings, spacer and spacer washer (without drive pinion or oil seal). Center bearing spacer between two bearing cones. Lubricate bearing cups and cones.

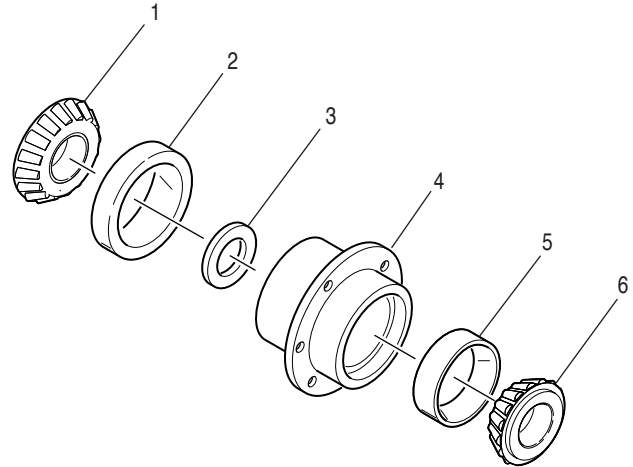

- |             |             |
|-------------|-------------|
| 1 — Bearing | 4 — Cage    |
| 2 — Cup     | 5 — Cup     |
| 3 — Spacer  | 6 — Bearing |

**Note:** When new gear set or pinion bearings are used, select nominal size spacer from the specification chart. If original parts are used, use spacer removed during disassembly.

2. With the bearings well lubricated, place the assembly in the press. Position sleeve so that load is applied directly to the back face of the outer bearing cone.

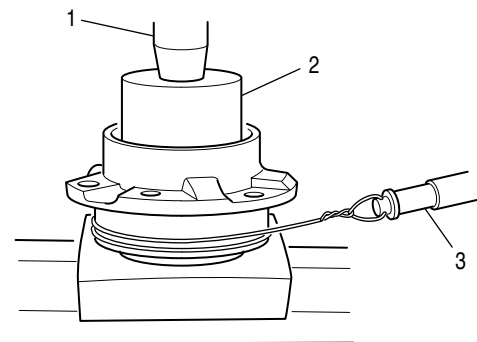

- |   |
|---|
| 1 — Press ram   |
| 2 — Sleeve must apply pressure to back face of outer bearing cone |
| 3 — Spring scale  |



3. Rotate pinion cage while applying press load (see chart below) to the assembly and check rolling torque. Wrap soft wire around the bearing cage, attach spring scale and pull. Preload is correct when torque required to rotate the pinion bearing cage is from 5–13 lbs. (2.5–6.0 kg.).

**Specifications for Pinion Bearing Trial Buildup Preload Test**

- Torque to Rotate Bearing Cage (w/o pinion seal)  
18 - 42 in. lbs (2.0 - 4.7 N•m)

	Forward Axles	Rear Axles
<b>Spring Scale Reading</b>	5 - 13 lbs. (2.5 - 6.0 kg)	
<b>Press Loads</b>	17-19 Tons (15.4 - 17.2 Metric Tons)	14-15 Tons (12.7- 13.6 Metric Tons)
<b>Nominal Bearing Thickness Spacer</b>	0.496 in. (12.60 mm)	0.638 in. (16.21 mm)

Read only the torque value after the bearing cage starts to rotate.

4. If necessary, adjust pinion bearing preload by changing the pinion bearing spacer. A thicker spacer will decrease preload. A thinner spacer will increase preload.

**⚠ CAUTION:** Once correct bearing preload has been established, note the spacer size used. Select a spacer 0.001” larger for use in the final pinion bearing cage assembly. The larger spacer compensates for slight “growth” in the bearings which occurs when they are pressed on the pinion shank.

**⚠ IMPORTANT:** Do not assume that all assemblies will retain proper pre-load once bearings are pressed on pinion shank. **FINAL PRELOAD TEST MUST BE MADE IN EVERY CASE.**

**Final Buildup**

**Note:** During pinion bearing installation, locate each part in same position that was used in “trial buildup” preload test.

1. Press inner bearing cone on pinion.

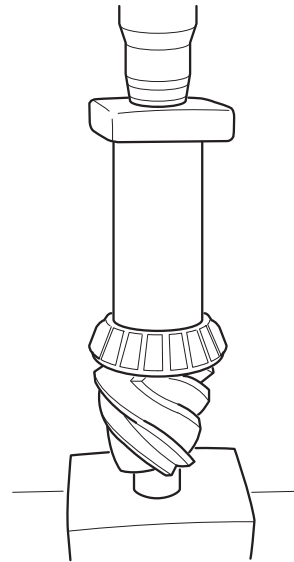

**⚠ IMPORTANT:** To prevent bearing damage, use suitable sleeve that only contacts inner race of bearing cone.

2. Install preselected bearing spacer.

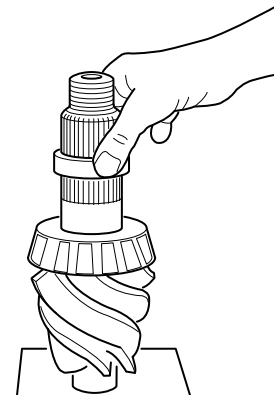

3. Install bearing cage on drive pinion.

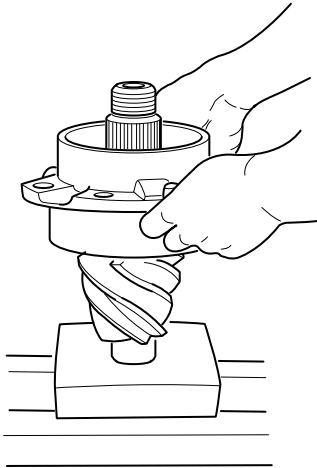

4. Press outer bearing cone on pinion.

**⚠ IMPORTANT:** To prevent bearing damage, spin cage while pressing outer bearing on.

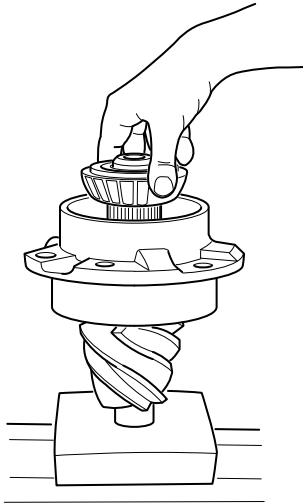

5. Apply clamp load to the pinion bearing cage assembly. Either install the yoke (or helical gear) and torque the pinion nut to specifications or use the press to simulate nut torque (see chart at right).

**Specifications for Pinion Bearing Trial Buildup Preload Test**

- Torque to Rotate Bearing Cage (w/o pinion seal)  
18 - 42 in. lbs (2.0 - 4.7 N•m)

	Forward Axles	Rear Axles
<b>Spring Scale Reading</b>	5 - 13 lbs. (2.5 - 6.0 kg)	
<b>Press Loads</b>	17-19 Tons (15.4 - 17.2 Metric Tons)	14-15 Tons (12.7- 13.6 Metric Tons)
<b>Nut Torque</b>	840 lbs. ft.* (1,140 N•m*)	575-703 lbs. ft. (780-953 N•m)

\*Torque nut to 840 lbs. ft. (1,140 N•m), then continue tightening nut to align nut slot to nearest hole in pinion shank.

**Vise Method**

- a. if the yoke and nut are used, mount the assembly in a vise, clamping yoke firmly.

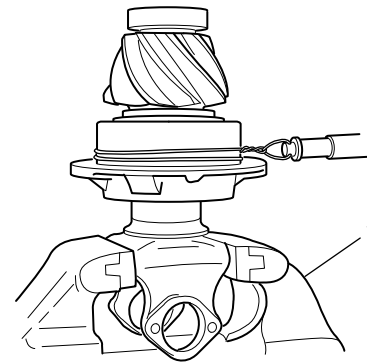

1 — Vise

## Press Method

- a. If a press is used, position a sleeve or spacer so that load is applied directly to the back face of the outer bearing cone.

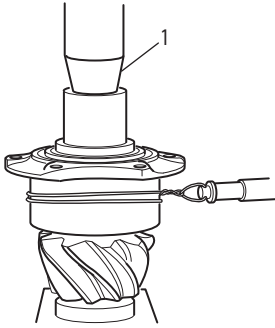

1 — Press

6. Measure Pinion Bearing Preload: Use a spring scale to test the assembly rolling torque. To use the spring scale, wrap flexible wire around the bearing cage, attach the scale and pull. Preload is correct when torque required to rotate the pinion bearing cage is from 5–13 lbs. This specification is translated into lbs. in. readings in the previous chart.

**CAUTION:** Read only the torque value after the bearing cage starts to rotate.

7. Adjust Pinion Bearing Preload: If necessary, adjust pinion bearing preload. Disassemble the pinion bearing cage as recommended in this manual and change the pinion bearing spacer. A thicker spacer will decrease preload. A thinner spacer will increase preload.

**IMPORTANT:** Use the correctly sized spacer. Do not use shim stock or grind spacers. These practices can lead to loss of bearing preload and gear or bearing failure.

8. Press pilot bearing on pinion.

**IMPORTANT:** To prevent bearing damage, use suitable sleeve that only contacts the inner race of bearing cone.

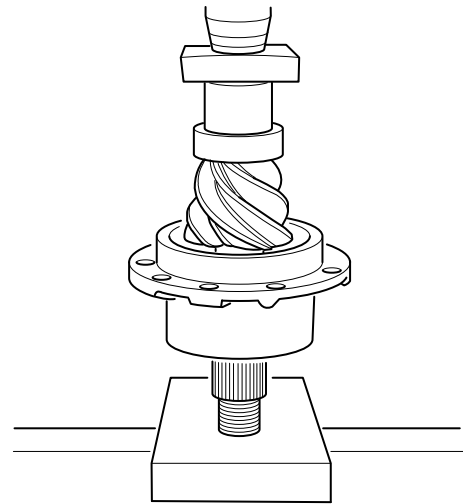

9. Stake pilot bearing using staking tool. This is essential to retain the bearing.

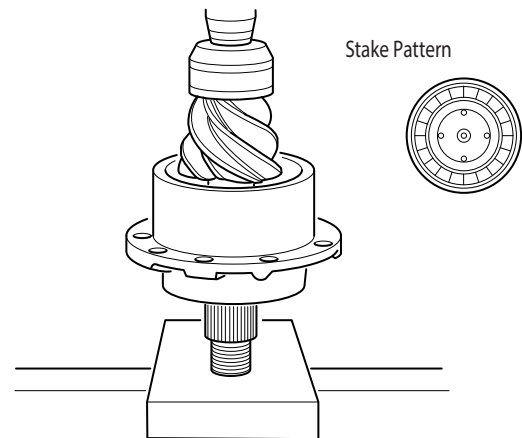

### Install Drive Pinion Assembly

1. Place shim pack on carrier making sure holes are properly aligned. Make sure shims are flat with no kinks or bends.

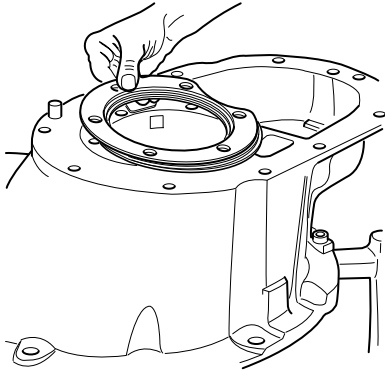

**Note:** If gear set is to be reused, install same quantity and size of shims removed during disassembly. When installing a new gear set, use nominal shim pack indicated.

#### Nominal Shim Pack

Axle	in.	mm
Rear	0.023	0.584

2. Install drive pinion assembly. Install bearing cage cap screws and lock washers. Torque cap screws to 114-140 lb-ft. (155-190 N•m).

**Note:** Use a dummy yoke (if available) in place of helical gear. This will result in easier disassembly and reassembly during carrier adjustments.

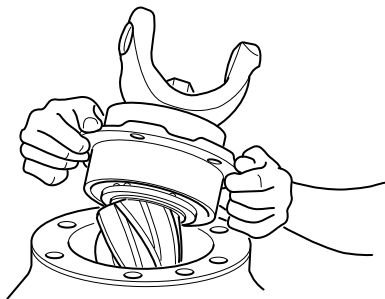

**Note:** Do not install cotter roll until carrier adjustments are completed.

3. If dummy yoke was used, remove nut and yoke. Install helical gear on pinion. Install M42 X 1.5 nut and torque to 840-1,020 lb-ft. (1,140-1,383 N•m).

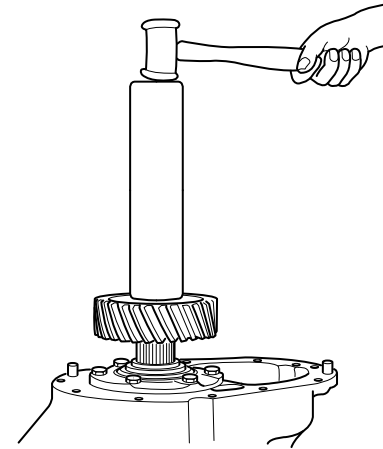

**! IMPORTANT:** Torque to 840 lbs. ft. (1,140 N•m), then continue tightening nut to align slot with the nearest hole in pinion shank. Install roll pin.

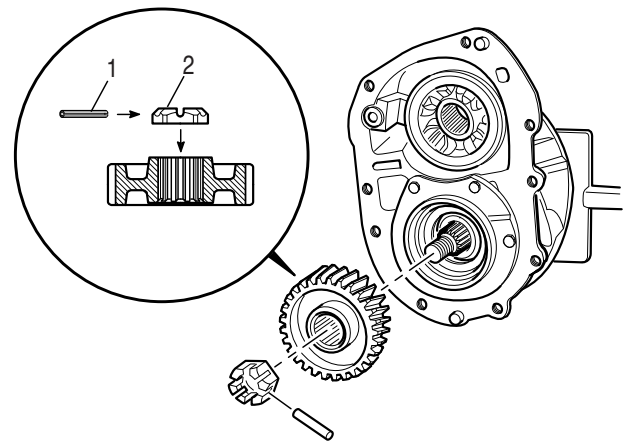

- 1 — Roll nut
- 2 — Slotted nut

Wheel Differential - Forward

Parts Exploded View

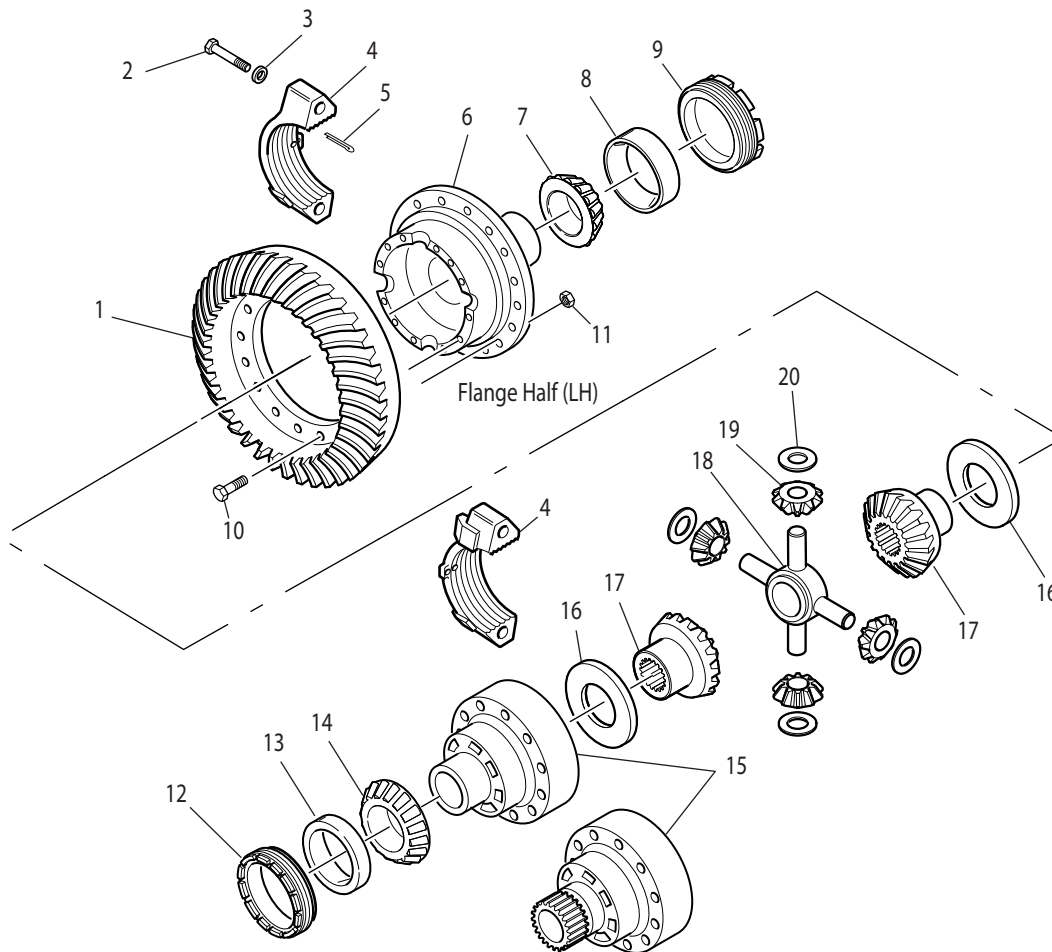

- |   |   |
|---|---|
| <b>1</b> — Ring gear                            | <b>11</b> — Nut                                 |
| <b>2</b> — Cap screw                            | <b>12</b> — Diff. bearing adjuster - plain half |
| <b>3</b> — Flat washer                          | <b>13</b> — Bearing cup - plain half            |
| <b>4</b> — Diff. carrier bearing caps           | <b>14</b> — Bearing cone - plain half           |
| <b>5</b> — Cotter pin                           | <b>15</b> — Diff. case - RH (plain half)        |
| <b>6</b> — Diff. case - LH (flange half)        | <b>16</b> — Side gear thrust washer             |
| <b>7</b> — Bearing cone - flange half           | <b>17</b> — Side gear                           |
| <b>8</b> — Bearing cup - flange half            | <b>18</b> — Diff. spider                        |
| <b>9</b> — Diff. bearing adjuster - flange half | <b>19</b> — Side pinion                         |
| <b>10</b> — Bolt                                | <b>20</b> — Side                                |

**Disassemble, Overhaul, and Assemble Wheel Differential - Forward**

**Disassemble Wheel Differential**

**⚠ IMPORTANT:** During following procedure, place differential assembly on malleable surface to prevent damage when ring gear falls off its mounting position.

1. Remove nuts and bolts fastening ring gear to differential cases, allowing gear to fall free. If gear does not fall, tap outer diameter with soft mallet to loosen.

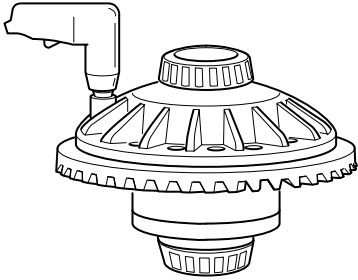

2. Punch mark differential cases for correct location during reassembly. Remove cap screws and lift off plain differential case half.

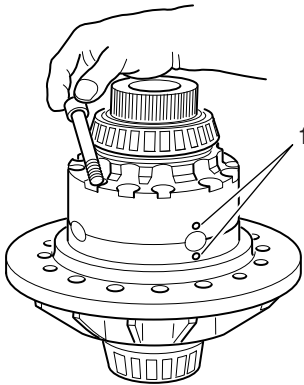

1 — Punch marks

3. Lift out side gear and thrust washer.

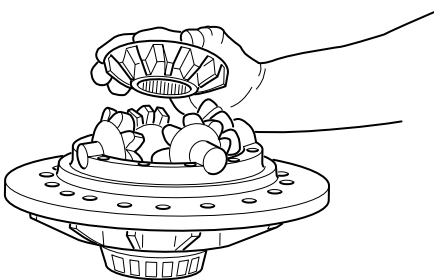

4. Lift out spider, side pinions and thrust washers.

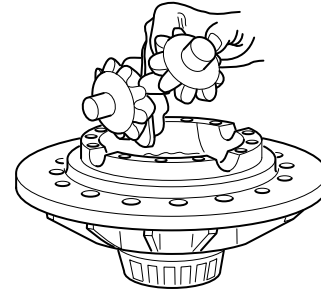

5. Remove remaining side gear and thrust washer.
6. Remove bearing cones from case halves using suitable puller.
7. Remove bearing cone from plain case half in two steps:
  - a. Mount puller vertically to split bearing. This action will start moving bearing off case.

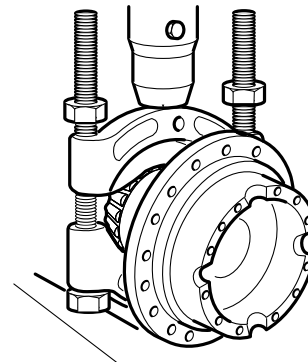

- b. Mount puller horizontally to remove cone.

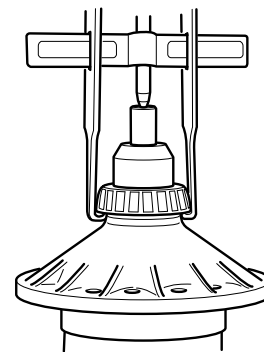

8. Remove bearing cone from flanged case half using suitable puller.

**Overhaul and Assemble Wheel Differential**

**⚠ IMPORTANT:** To prevent bearing damage, use suitable sleeve that only contacts the inner race of the cone. A used bearing race would be a suitable tool. This tool should have a slit cut if the ID is the same as the fange OD.

1. Press new ange half bearing cones on differential case halves.

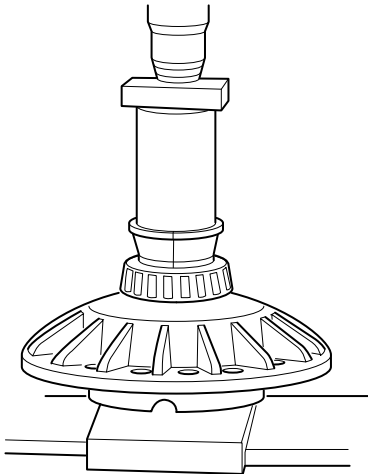

2. Press new plain half bearing cones on differential case halves.

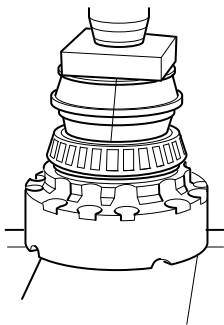

3. Place thrust washer and side gear in flanged differential case.

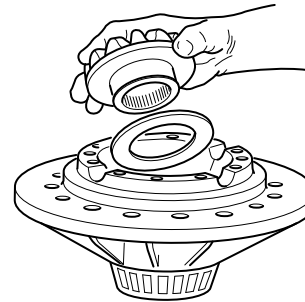

4. Lubricate all differential parts.

5. Assemble side pinion and thrust washers on spider. Place this assembly in flanged differential case. Rotate gears and check for proper mesh.

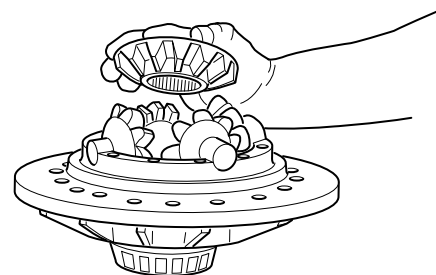

6. Place side gear and thrust washer on side pinions.

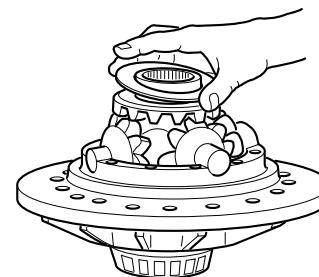

7. Align punch marks and install plain case half. Install cap screws and tighten to 114–140 lb-ft. (155–190 N•m). Check differential for free rotation by turning side gear hub.

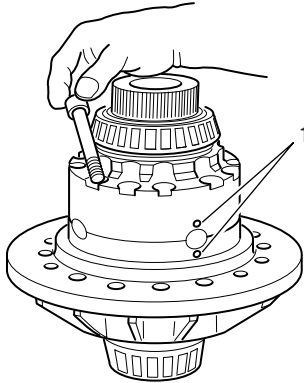

1 — Punch marks

8. Install ring gear. Secure with bolts and nuts.

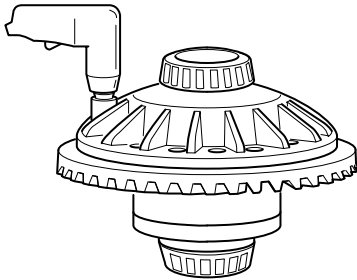

**Bolt No. Torque Specs.**

126219	215-255 lb-ft. (N•m 292-346)
--------	------------------------------

9. Lower assembled differential assembly in to the carrier using a hoist and a strap. Be careful not to damage the differential bearings lowering the assembly.

10. Install the bearing cup and bearing adjuster to the flange half side first.

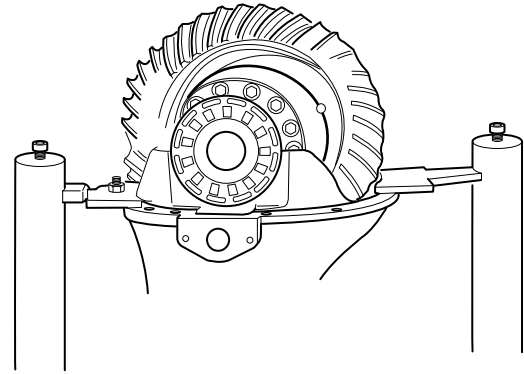

11. Install the bearing cup and bearing adjuster to the plain half side. Use a long screwdriver or bar to lift the differential up while installing the cup and bearing adjuster.



**Measure and Adjust Carrier Assembly**

**Adjust Backlash and Preload**

1. Turn the flange half bearing adjuster in until the ring gear contacts the pinion (zero backlash) then back the adjuster out two notches of the adjuster lugs.

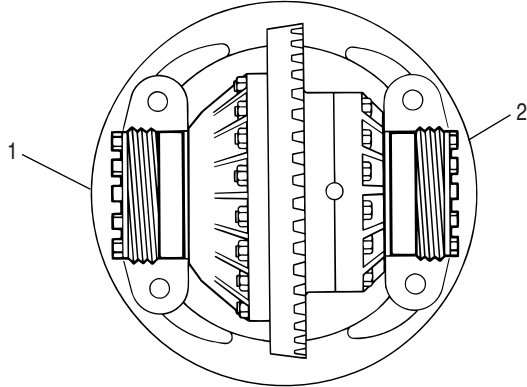

- 1 — Flange half
- 2 — Plain half

2. Tighten the plain half adjuster until the bearing cup just starts to turn, this is a zero bearing preload.

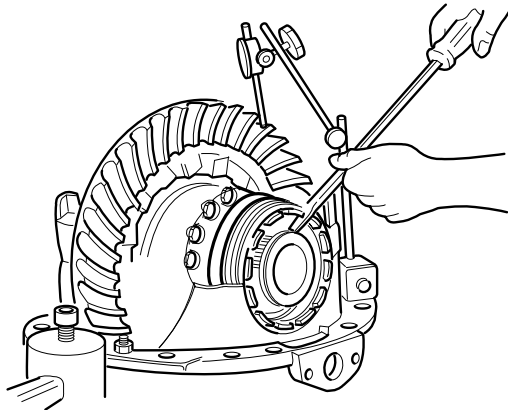

3. Tighten the plain half adjuster two lug notches. Start with the notch at the top, count two notches counterclockwise on the adjuster, turn the adjuster so that the notch is facing straight up. You now have a two notch preload.

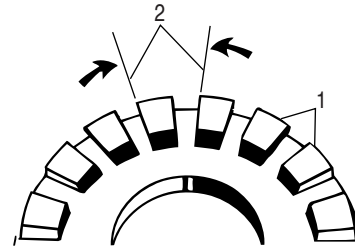

- 1 — Flange half
- 2 — Plain half

4. Use a rubber mallet to make certain that both bearing adjusters are fully seated.

5. Measure backlash. Make sure it is within specification of 0.006"–0.018".

**TIP:** To give yourself room to adjust contact pattern, set it between 0.010"–0.012".

### Change Backlash Setting

If you have too much backlash the ring gear needs to move closer to the pinion. Back off the plain half adjuster, count the number of notches you back it off, each notch equals about 0.003" of backlash.

**! IMPORTANT:** In order to maintain the differential bearing preload you will need to turn the flange half bearing adjuster the same amount in the same direction. If you need more backlash reverse this procedure.

1. Install carrier bearings caps and torque carrier cap bolts to 350–428 lbs. ft. (475–580 N•m).
2. **Recheck backlash:** if the bearing adjusters were not in straight or fully seated the backlash will change.
- c. **Used Gearing:** Reset to backlash recorded before disassembly.
- d. **New Gearing:** Backlash should be between 0.006 and 0.018".

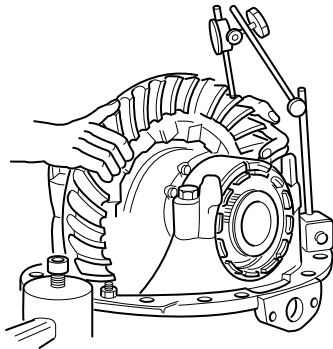

3. Check ring gear tooth contact pattern. Paint ring gear teeth and check tooth contact pattern. Correct tooth patterns. Checking and adjusting procedures are on [pages 47-48](#).
4. Install bearing adjuster cotter pins.

### Measure Ring Gear Runout

#### Measure Ring Gear Total

1. Measure ring gear total radial run out. (Indicator reading should not exceed 0.010").

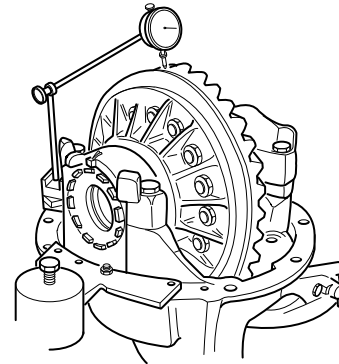

2. Measure ring gear total back face run out (Indicator reading should not exceed 0.010").

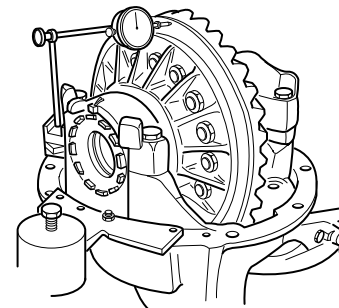

**Adjust Ring and Pinion Tooth Contact Pattern**

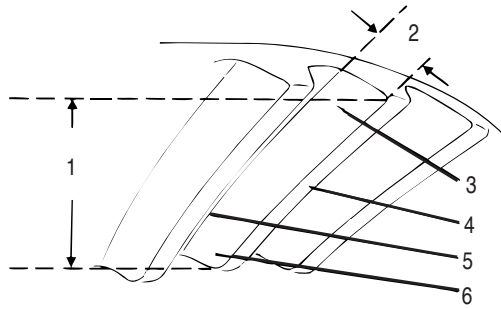

- 1 — Face width
- 2 — Tooth depth
- 3 — Heel
- 4 — Top land
- 5 — Root
- 6 — Toe

**Note:** Rear axle gearing is shown in the following instructions. Correct tooth contact patterns and adjustments are the same for forward and rear axles.

1. Identify if new or used gearing.
2. Check tooth contact pattern (new or used gearing).

**New Gearing - Correct Pattern**

Paint six ring gear teeth 180° apart with marking compound and roll the gear to obtain a contact pattern. The correct pattern is slightly below center on the ring gear tooth with length-wise contact up off the toe. The length of the pattern in an unloaded condition is approximately one-half to two-thirds of the ring gear tooth in most models and ratios.

The pattern could vary in length and should cover 1/2 tooth or more (face width). The pattern should be evenly centered between tooth top land and root and should be up off the tooth toe.

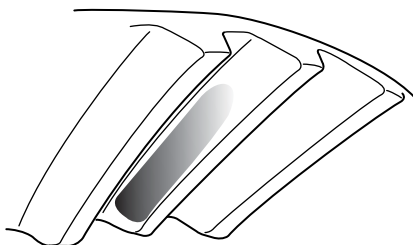

**Used Gearing - Correct Pattern**

Used gearing will not usually display the square, even contact pattern found in new gear sets. The gear will normally have a “pocket” at the heel end of the gear tooth. The more use a gear has had, the more the line becomes the dominant characteristic of the pattern.

Adjust used gear sets to display the same contact pattern observed before disassembly. A correct pattern is up off the toe and centers evenly along the face width between the top land and root. Otherwise, the length and shape of the pattern are highly variable and is considered acceptable as long as it does not run off the tooth at any point.

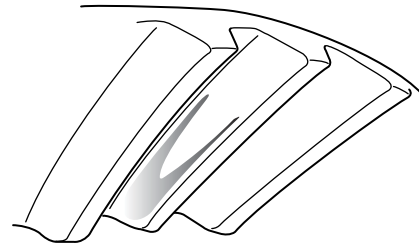

1 — Pattern along the face width could be longer

**Adjust Contact Pattern**

If necessary, adjust the contact pattern by moving the ring gear and drive pinion.

- Ring gear position controls the backlash. This adjustment moves the contact pattern along the face width of the gear tooth.
- Pinion position is determined by the size of the pinion bearing cage shim pack. It controls contact on the tooth depth of the gear tooth.

These adjustments are interrelated. As a result, they must be considered together even though the pattern is altered by two distinct operations. When making adjustments, first adjust the pinion, then the backlash. Continue this sequence until the pattern is satisfactory.

### Adjust Pinion Position

If the gear pattern shows incorrect tooth depth contact, change drive pinion position by altering the shim pack. Used gears should achieve proper contact with the same shims removed from the axle at disassembly.

**Note:** Check ring gear backlash after each shim change and adjust if necessary to maintain the 0.006" to 0.018" specifications.

If the pattern is too close to the top land of the gear tooth, remove pinion shims. Move pinion toward the ring gear.

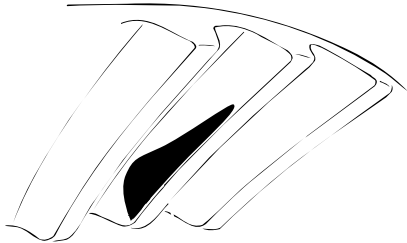

If the pattern is too close to the root of the gear tooth, add pinion shims. Move pinion away from the ring gear.

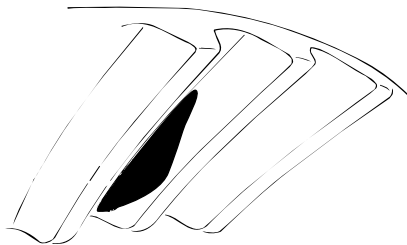

### Adjust Ring Gear Position (Backlash)

If the gear pattern shows incorrect face width contact, change backlash by adjusting the ring gear.

If the pattern is too close to the edge of the tooth toe, move the ring gear away from the pinion to increase backlash.

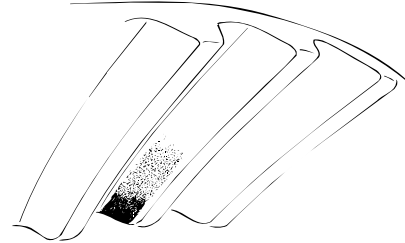

3. Loosen the bearing adjuster on the teeth side of the ring gear several notches.
4. Loosen the opposite adjuster one notch.
5. Return to adjuster on teeth side of ring gear and tighten adjuster until it contacts the bearing cup.
6. Continue tightening the same adjuster 2 or 3 notches and recheck backlash.

If the pattern is concentrated at the heel (too far up the tooth), move the ring gear toward the pinion to decrease backlash.

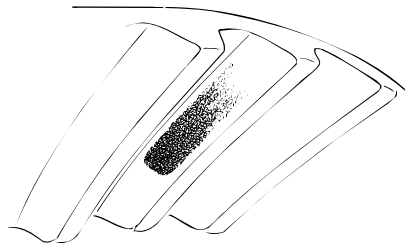

7. Loosen the bearing adjuster on the teeth side of the ring gear several notches.
8. Tighten the opposite adjuster one notch.
9. Return to adjuster on teeth side of ring gear and tighten adjuster until it contacts the bearing cup.
10. Continue tightening the same adjuster 2 or 3 notches and recheck backlash.

Wheel Differential Lock - Forward

Parts Exploded View

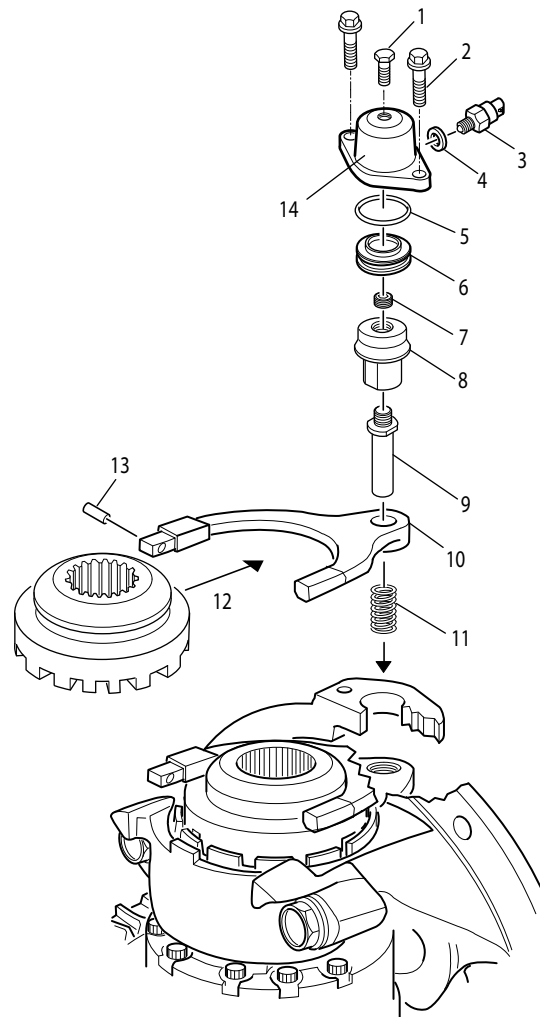

- |                                   |                            |
|-----------------------------------|----------------------------|
| <b>1</b> — Piston engagement bolt | <b>8</b> — Piston driver   |
| <b>2</b> — Cap screw              | <b>9</b> — Push rod        |
| <b>3</b> — Switch                 | <b>10</b> — Clutch fork    |
| <b>4</b> — Washer                 | <b>11</b> — Spring         |
| <b>5</b> — O-ring                 | <b>12</b> — Sliding clutch |
| <b>6</b> — Piston                 | <b>13</b> — Pin            |
| <b>7</b> — Setscrew               | <b>14</b> — Piston cover   |

### Install and Adjust Wheel Differential Lock

**Note:** With differential carrier completely assembled and adjusted, install differential lock as follows:

1. Install fixed curvic clutch on splined hub of flanged differential case, then install snap ring.
2. If shift fork and sliding curvic clutch are disassembled, engage fork with clutch hub and install spring pin in the long leg of the fork. See illustration for fork mounting position on clutch.
3. Position compression spring, shift fork and clutch assembly in shift opening of the carrier. Align pilot hole of shift fork with pilot hole of carrier. Install pushrod, engaging shift fork head, and compression spring in carrier.
4. Install new o-ring on piston.
5. Lubricate piston and o-ring with silicone grease and install piston assembly in cylinder. Position piston with small diameter hub toward closed end of cylinder.
6. Screw piston driver on push rod.
7. Tighten piston driver until shift fork clutch is approximately 0.030 of an inch from the fixed clutch.

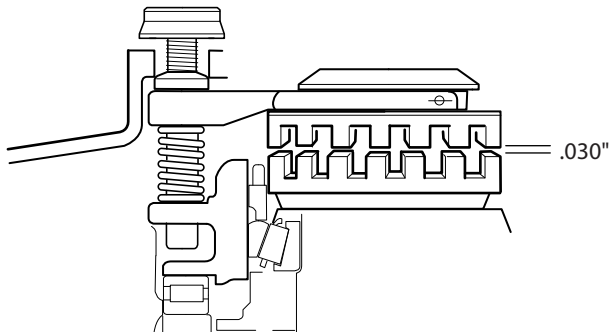

8. Push down by hand on the piston driver, both clutches must be completely engaged.
9. Install set screw in piston driver, torque to 12–15 lb-ft. (16–20 N•m).

**CAUTION:** On 3.90 ratio models only, a washer (P/N 210288) must be used between the piston driver and piston. Failure to install the washer will cause engagement and disengagement problems in the differential lock.

10. Trial fit, install piston cover assembly. Hand tighten cap screws.

11. Screw in manual engagement screw, by hand approximately 1 inch or until snug fit (light resistance pressure is felt) both clutches must be completely engaged.
  12. Remove manual engagement screw, clutches must completely disengaged. Repeat above procedure if clutches not completely disengaged.
- Note:** Fork adjustment is correct when curvic clutch teeth are fully engaged with the fork free when moved by hand. When air pressure is released or the manual bolt is removed, the shift assembly should disengage freely.
13. When adjustment is complete, torque fasteners to 28–35 lb-ft. (38–47 N•m).
  14. Install selector switch in cylinder cover. Torque switch to 10–12 lb-ft. (14–16 N•m).
  15. Check selector switch operation. Check switch electrically with an ohmmeter or continuity tester. Switch should close (show continuity) when clutches are engaged and should open (no continuity) when clutches are disengaged.

## Install and Adjust Ring Gear Thrust Bolt

1. Thread thrust screw into the carrier until firm contact with the back face of the ring gear is made.
2. Loosen the thrust screw 1/4 turn to obtain the correct adjustment of 0.020" (.50mm) clearance between gear face and screw. Tighten jam nut, holding thrust screw stationary with a wrench, torque jam nut 150–190 lbs. ft. (203–258 N•m).
3. Recheck to assure minimum clearance during full rotation of ring gear.

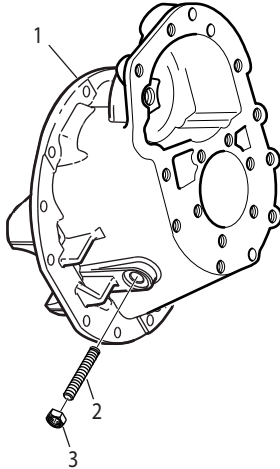

- 1** — D-head carrier or front carrier  
**2** — Thrust bolt  
**3** — Thrust bolt jam nut

Housing and Output Shaft Assembly - Forward

Parts Exploded View

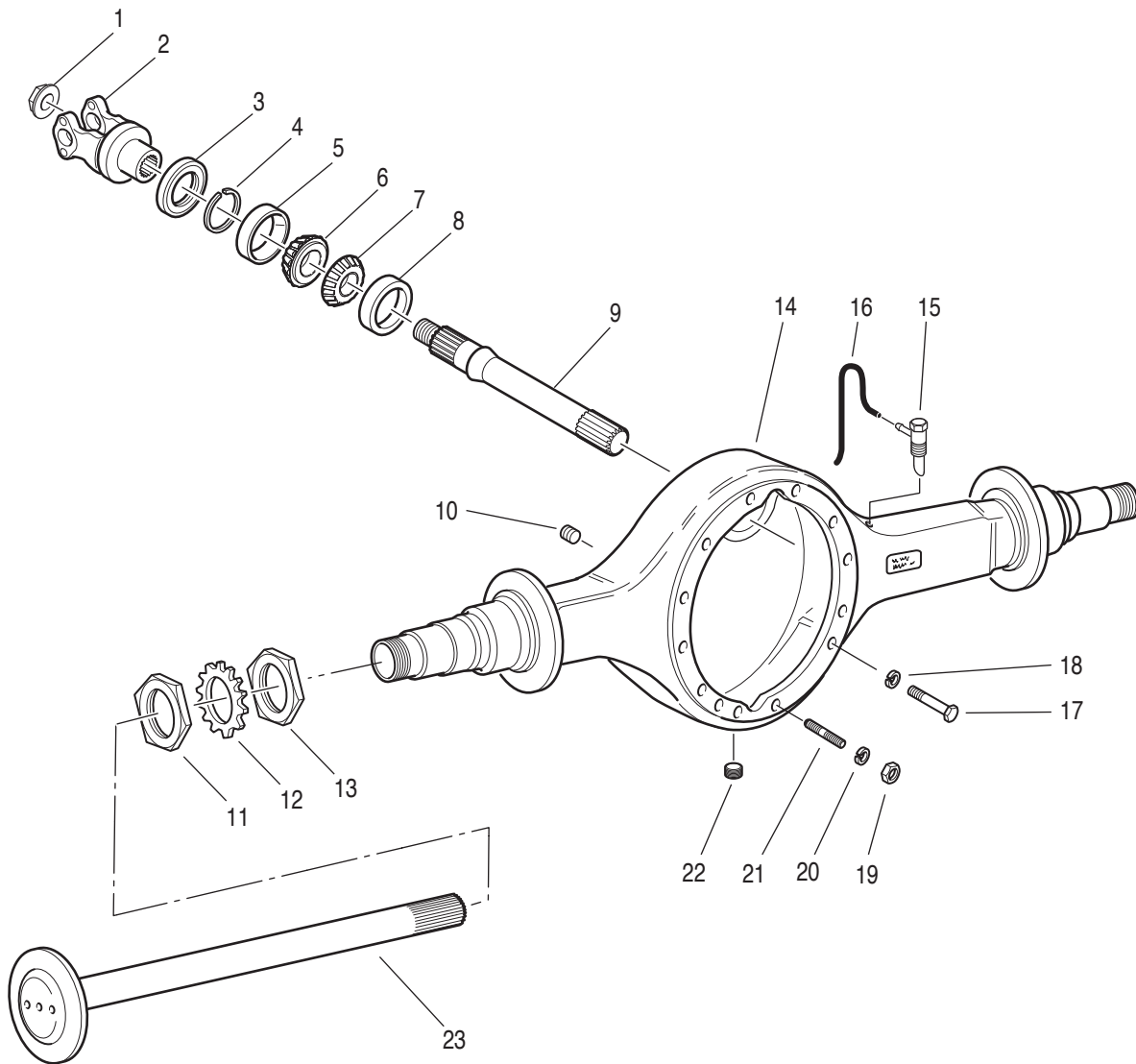

- |                               |                           |                                |
|-------------------------------|---------------------------|--------------------------------|
| <b>1</b> — Output shaft nut   | <b>9</b> — Output shaft   | <b>17</b> — Carriage cap screw |
| <b>2</b> — Output yoke        | <b>10</b> — Fill plug     | <b>18</b> — Lock washer        |
| <b>3</b> — Output seal        | <b>11</b> — Jam nut       | <b>19</b> — Nut                |
| <b>4</b> — Snap ring          | <b>12</b> — Locking ring  | <b>20</b> — Lock washer        |
| <b>5</b> — Outer bearing cup  | <b>13</b> — Spindle nut   | <b>21</b> — Stud               |
| <b>6</b> — Outer bearing cone | <b>14</b> — Axle housing  | <b>22</b> — Drain plug         |
| <b>7</b> — Inner bearing cone | <b>15</b> — Breather      | <b>23</b> — Axle shaft         |
| <b>8</b> — Inner bearing cup  | <b>16</b> — Breather hose |                                |



**Disassemble Output Shaft Assembly**

**Note:** For forward axle rear covers that are removable the output shaft may be removed when the cover is in or out of the axle assembly.

1. Disconnect the inter-axle driveline at the forward axle rear cover position.
2. Remove yoke nut (shoulder nut).
3. Remove yoke from output shaft using appropriate tool.

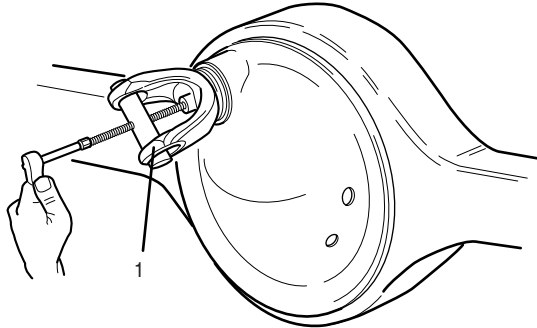

1 — Yoke puller tool

**TIP:** A yoke puller tool may be made from the center section of most gear puller tools, or may be purchased from your tool distributor.

4. Remove oil seal.
5. Remove snap ring.
6. Remove output shaft and outer bearing cup as an assembly.

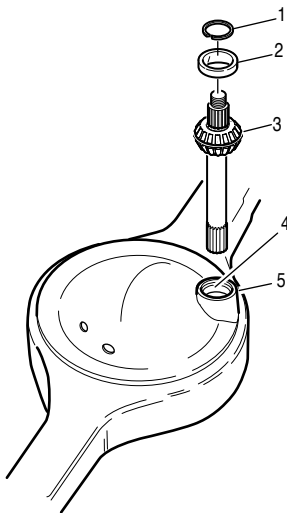

1 — Snap ring  
 2 — Outer bearing cup  
 3 — Output shaft assembly  
 4 — Inner bearing cup  
 5 — Rear cover assembly

**TIP:** It may be helpful to loosely reinstall the yoke and shoulder nut giving the technician more of an area to grip when removing the output shaft.

7. Remove the inner bearing cup from rear cover assembly. This may be removed from inside the axle housing when the carrier is removed, or by removal of the forward axle rear cover.
8. Remove both inner and outer bearing from output shaft.

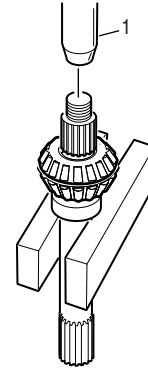

1 — Press

9. Remove output shaft inner bearing cup.

**Note:** Components such as the inter-axle driveline, yoke, oil seal and output shaft assembly should have been removed according to normal service procedures. Removing the differential assembly from the axle housing is not necessary, but would ease the removal process of the inner bearing cup from the cover bore.

- e. Using a bearing puller tool, remove the inner bearing cup.
- f. Visually inspect the inner-machined bore surface of the welded-on cover for nicks and burrs. Repair if necessary.

**Overhaul and Assemble Output Shaft Assembly**

**Note:** Lubricate the parts with gear lube during assembly.

1. The output shaft bearings are assembled with both bearing cones back to back. Use a press and a sleeve to install one bearing at a time.

**CAUTION:** To prevent bearing damage, use a suitable sleeve that only contacts the bearing race.

2. Apply pressure until the inner bearing cone touches the shoulder of the output shaft.

3. Apply pressure until the back of the outer bearing cone touches the back of the inner bearing.

**Note:** Axle housings with welded-on covers procured through service will include the inner bearing cup as part of the “service” axle housing assembly. Go to Step 6 if the inner cup has already been installed.

4. Lightly coat the output bore of the axle housing cover with a 9.5 (.38) wide application of Loctite 680 where the bore contacts the inner bearing cup. Do not apply Loctite outside of this area—to the bearing rollers or outboard of the inner cup bore. Improper application of the Loctite could lock the rollers or cause excessive pre-load.

**CAUTION:** Add loctite adhesive to the inner bearing surface of the housing and NOT to the bearing race itself. If added to the race, excessive adhesive could get on the surface of the outer bearing race journal during installation and cure the outer cap in place with excessive pre-load.

5. Using a sleeve and driver (hammer), install the inner bearing cup.

6. Put the output shaft and bearing assembly into the axle housing assembly.

7. Using a sleeve and driver (hammer), install the outer bearing cup into the housing assembly over the output shaft bearing cone.

8. Using snap ring pliers, install the snap ring that fastens the outer bearing cup into the welded-on cover assembly.

9. Check the end-play of the output shaft. New assemblies should measure 0.001” to 0.015”.

**Note:** Use the bearing cup driver to insure seating of snap ring after installation with snap ring pliers.

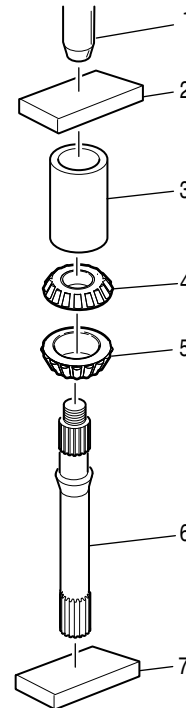

- 1 — Press
- 2 — Plate
- 3 — Sleeve
- 4 — Press bearing on second
- 5 — Press bearing on first
- 6 — Output shaft
- 7 — Plate

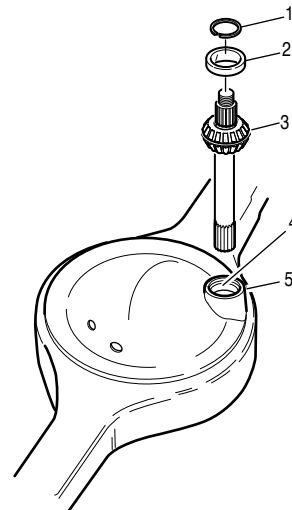

- 1 — Snap ring
- 2 — Bearing cup
- 3 — Output shaft assembly
- 4 — Inner bearing cup
- 5 — Rear cover

10. Install output yoke.

11. Install yoke nut using one of the following options:

- g. Install a new nut with the pre-applied thread adhesive compound. Tighten the nut to the specified torque 680–832 lbs. ft. (920–1,130 N•m).
- h. If a new nut with pre-applied thread adhesive compound is unavailable, apply “Loctite 277” or “271” (available in 0.5 ml tube—Dana P/N 129293) to the nut along two threads, for at least two flats (120°) of the nut midway through the thickness. Tighten the nut to the specified torque 680–832 lb-ft. (530–1,130 N•m).

 **IMPORTANT:** Follow the instructions specified by the thread adhesive manufacturer when applying thread adhesive compound.

**Note:** Use of a torque multiplier is recommended. If you can't get the correct torque on yoke nut, try torquing the nut with the truck wheels on the ground and with the axle shafts installed.

12. Install axle shafts and axle stud nuts (If used, also install lock washers and taper dowels).

13. Connect inter-axle driveline. Make sure driveline is properly phased. Lubricate U-joints.

14. Add axle lubricant. Fill to bottom of filler hole.

 **IMPORTANT:** When axle has been disassembled or housing, axle shafts or wheel equipment replaced, check axle assembly for proper differential actions before operating vehicle. Wheels must rotate freely and independently.

15. Road test vehicle to bring axle lubricant up to temperature. Recheck joints, drain and fill plugs for leakage. Retighten as necessary.

### Measure and Adjust

**Note:** Use bearing cup driver to insure seating of snap ring after installation with snap ring pliers. See illustration for steps 1–4.

1. Assemble cover assembly to axle housing.
2. Position dial indicator at yoke end of output shaft.
3. Push in on output shaft and zero the dial indicator.
4. Using a pry bar, move output shaft axially and measure/record end-play.

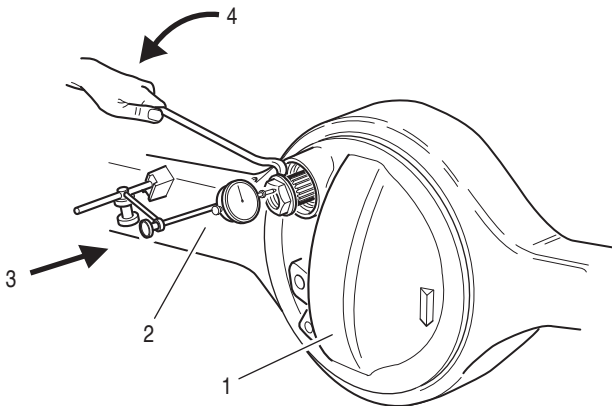

Correct end-play for a new assembly is 0.001" to 0.015". The maximum end-play for a used assembly is no more than 0.015". If end-play is incorrect, contact Dana.

5. Install oil seal. Follow seal replacement procedures on [page 83](#) of this manual.
6. Install yoke.
7. Install yoke nut. One of the following options may be utilized:
  - i. Install a new nut with the pre-applied thread adhesive compound. Tighten the nut to the specified torque 680–832 lbs. ft. (920–1130 N•m).
  - j. If a new nut with pre-applied thread adhesive compound is unavailable, apply “Loctite 277” or “271” (available in 0.5 ml tube—Dana P/N 129293) to the nut along two threads, for at least two flats (120°) of the nut midway through the thickness (See illustration). Tighten the nut to the specified torque 680–832 lbs. ft. (920–1130 N•m).

### Replace Seal

Dana strongly recommends using seal drivers when installing new seals. Use the proper driver to make sure that the seal is square and installed to the proper depth.

**CAUTION:** Oil seals can be easily damaged prior to installation. Use care when handling the new seal to prevent damage or contamination. Leave the seal in its package until installation. On new yokes, leave the protector on the yoke until it is installed on the shaft to prevent damage or contamination.

1. Inspect axle end-play at the yoke (see [page 9](#)). Service if beyond specified limit.
2. Remove the old yoke using appropriate tool. A yoke puller tool may be made from the center section of most gear puller tools, or may be purchased from your local tool distributor.

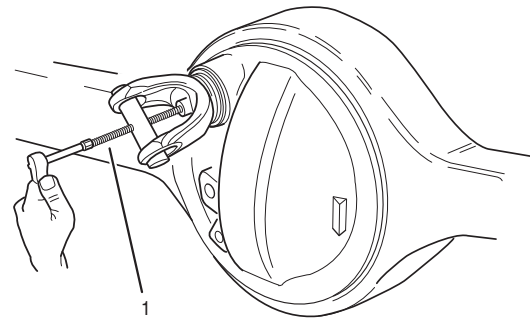

1 — Yoke puller tool

3. Remove seal. Use care when removing the old seal to prevent damage to the housing seal bore.
4. Inspect the seal bore area for any damage (nicks, gouges, corrosion). Carefully remove any slight damage with a crocus cloth. Clean the bore area to remove any loose debris.

Do not use any silicone or permatex-type bore sealant with this seal.

5. Remove the new seal from its package and install with the proper driver:
  - Service kit #217414
  - D-Input-Use driver #126917 only
  - D-Output-Use insert #128706 with driver #126917
  - R-Pinion-Use driver #126917 only

**⚠ CAUTION:** Due to the resiliency of the plastic driver, hammer rebound may occur when the seal is seated. Keep clear of the hammer rebound path!

6. Handle the seal by its outside diameter avoiding any contact with the seal lips. During installation, use the proper driver to make sure that the seal is mounted properly.
7. Use a rubber mallet to drive the seal tool in until the flange bottoms on the housing cover bore face. The flange will locate the seal at the proper depth.

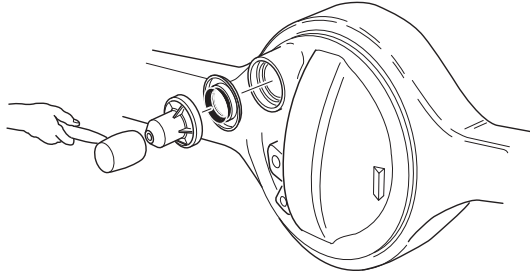

## Guidelines for Reusing Yoke

**⚠ CAUTION:** Do not use the yoke if it has any damage on the seal surface (nicks or scratches).

The surface of the yoke and the lips of the seal form a critical interface which retains the axle's lubricant while sealing the axle from outside contaminants. The condition of the yoke hub's surface is a very important factor in determining seal life.

Carefully inspect the seal surface area of the yoke hub for signs of wear and damage. Do not reuse the yoke if there is noticeable wear, such as heavy grooving, beyond normal polishing from the seal lips.

**Note:** Do not rework the yoke with abrasives such as emery paper or crocus cloth. Clean the surface of the yoke as necessary using chemical cleaners. Remove all trace of the chemicals from the yoke after cleaning.

**⚠ CAUTION:** Do not use wear sleeves. Wear sleeves increase the yoke hub surface diameter and cause premature seal wear and repeat seal failure.

Rear Assembly

Differential Carrier Assembly - Rear - Rear

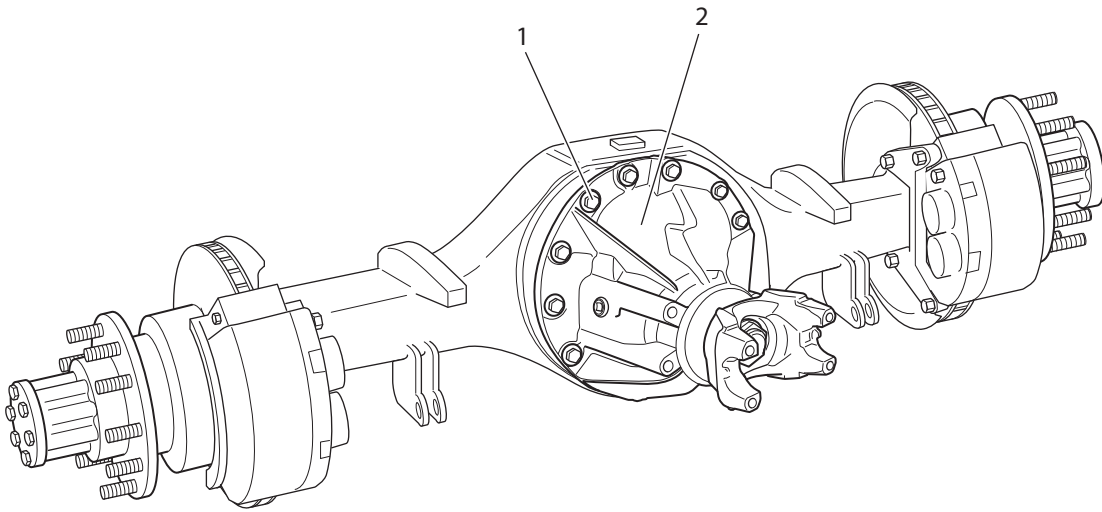

- 1 — Carrier fastener
- 2 — Carrier assembly rear assembly

## Differential Carrier - Rear

### Parts Exploded

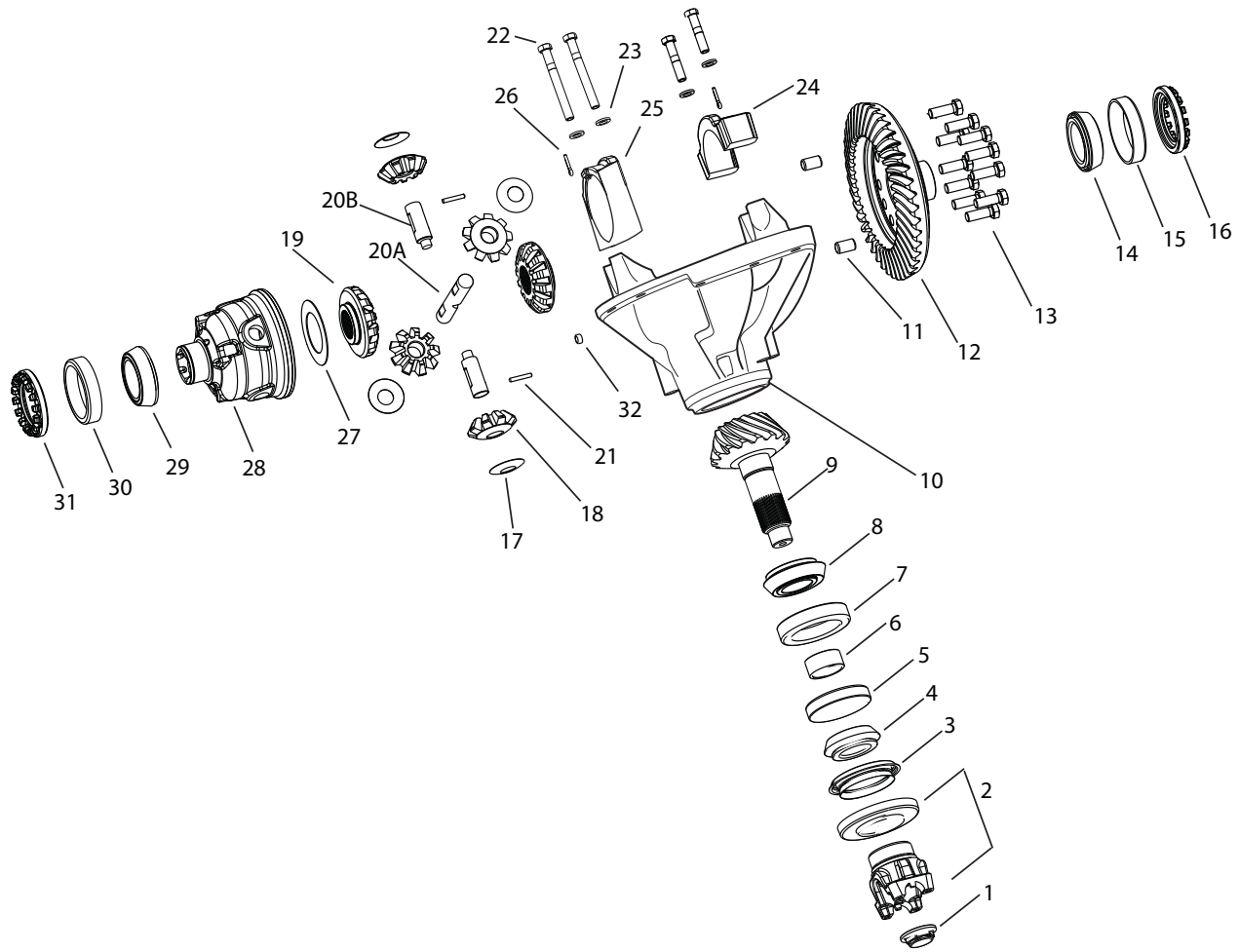

- |                                      |  |   |
|--------------------------------------|--|---|
| <b>1</b> — Pinion nut                | <b>12</b> — Ring gear                    | <b>23</b> — Flat washer                 |
| <b>2</b> — End yoke and slinger      | <b>13</b> — Ring gear bolts              | <b>24</b> — Flange half cap             |
| <b>3</b> — Oil seal                  | <b>14</b> — Flange half bearing cone     | <b>25</b> — Plain half cap              |
| <b>4</b> — Outer pinion bearing cone | <b>15</b> — Flange half bearing cup      | <b>26</b> — Cotter pin                  |
| <b>5</b> — Outer pinion bearing cup  | <b>16</b> — Flange half bearing adjuster | <b>27</b> — Side gear thrust washer     |
| <b>6</b> — Pinion spacer             | <b>17</b> — Side pinion thrust washer    | <b>28</b> — Plain half diff case        |
| <b>7</b> — Inner pinion bearing cup  | <b>18</b> — Side pinion                  | <b>29</b> — Plain half bearing cone     |
| <b>8</b> — Inner pinion bearing cone | <b>19</b> — Side gear                    | <b>30</b> — Plain half bearing cup      |
| <b>9</b> — Drive pinion              | <b>20</b> — A/B - Differential shaft     | <b>31</b> — Plain half bearing adjuster |
| <b>10</b> — Carrier housing          | <b>21</b> — Pin                          | <b>32</b> — Pipe plug                   |
| <b>11</b> — Diff case dowels         | <b>22</b> — Cap screw                    |   |

## Install Differential Carrier - Rear

**⚠ IMPORTANT:** Before installing carrier assembly, inspect and thoroughly clean interior of axle housing using an appropriate solvent and clean rag.

1. Apply Dana Spicer approved RTV compound on axle housing mating surface as shown in the illustration. Completely remove all old gasket material prior to applying new material. Compound will set in 20 minutes. Install carrier before compound sets or reapply.

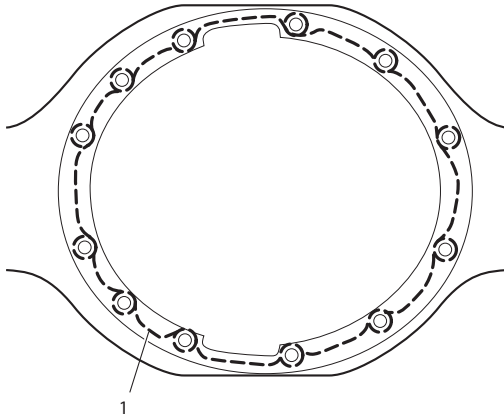

1 — Apply RTV gasket in this pattern

**Note:** To assist in installing complete differential carrier use two pieces of threaded rod (M14X2) threaded into carrier cap screw holes. Rod should be approximately 4" (102 mm) long. Use these to pilot the carrier into the housing.

2. Install carrier to housing, lock washers and cap screws. Torque to proper specification. Torque to 142–158lb-ft. (193–214 N•m).
3. Install axle shafts and axle stud nuts.
4. Add axle lubricant. Fill to bottom of filler hole in carrier.
5. Connect main driveline and lubricate joints.



## Drive Pinion

### Rear Axle Pinion Assembly Parts

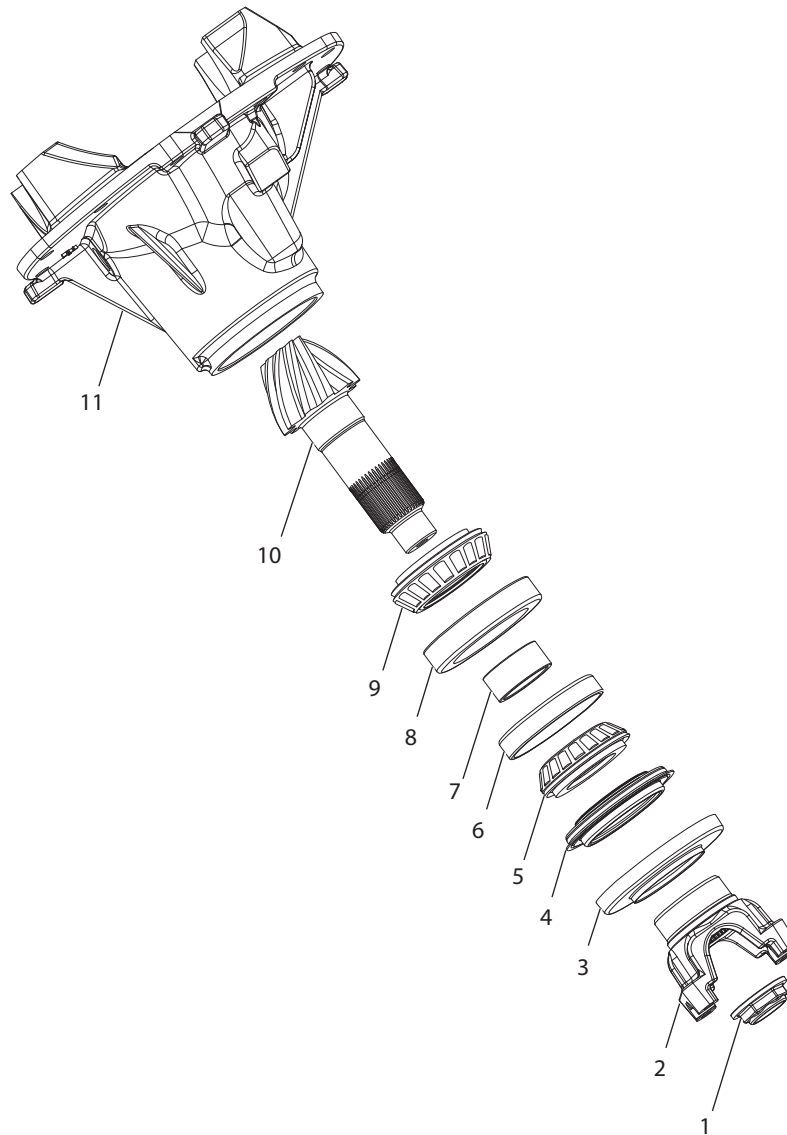

- |                                      |                                     |
|--------------------------------------|-------------------------------------|
| <b>1</b> — Pinion nut                | <b>7</b> — Pinion spacer            |
| <b>2</b> — End yoke                  | <b>8</b> — Inner pinion bearing cup |
| <b>3</b> — Slinger                   | <b>9</b> — Inner pinion bearing     |
| <b>4</b> — Oil seal                  | <b>10</b> — Drive pinion            |
| <b>5</b> — Outer pinion bearing cone | <b>11</b> — Carrier                 |
| <b>6</b> — Outer pinion bearing cup  |                                     |

## Pinion Disassembly

1. Remove yoke nut.
2. Remove yoke using a yoke puller service tool.

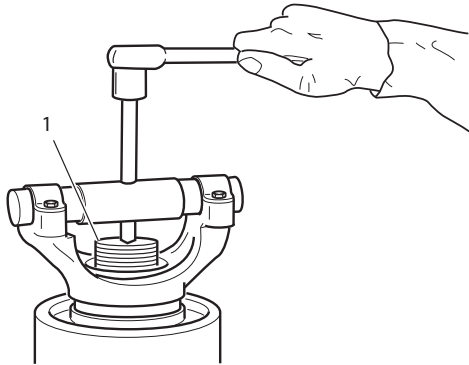

1 — Yoke puller

3. Remove oil seal.
4. Place carrier in a press with threaded end of pinion face up.
5. Place a wood block under pinion to avoid damage to gear teeth.

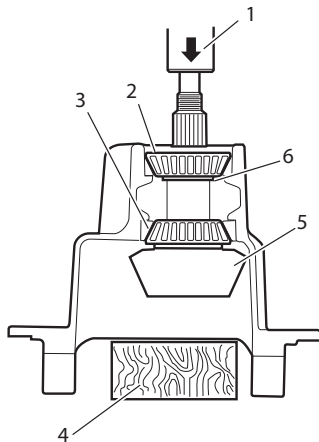

- |                   |                            |
|-------------------|----------------------------|
| 1 — Press         | 4 — Wood block             |
| 2 — Outer bearing | 5 — Drive pinion           |
| 3 — Inner bearing | 6 — Bearing preload spacer |

6. Press pinion through outer bearing and out of carrier casting.

7. Remove bearing preload spacer and save for use in reassembly.
8. Remove inner bearing cone from pinion using a split-type puller. Use two procedure steps to remove each bearing.
  - a. Mount puller vertically to separate the bearing. This action will force puller halves under bearing and start moving bearing off pinion.

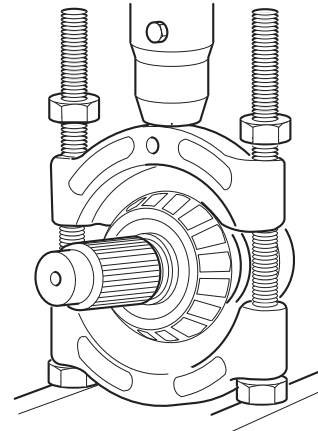

- b. Mount puller horizontally to press pinion out of bearing.

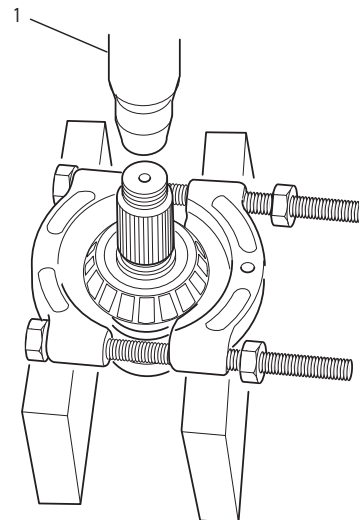

1 — Press

9. If bearings are to be replaced, remove bearing cups from carrier casting at this time. Pinion removal complete.

## Pinion Installation

### Final Buildup

**Note:** Do not install oil seal in carrier until bearing preload is correctly adjusted.

1. Press inner bearing cone on pinion.

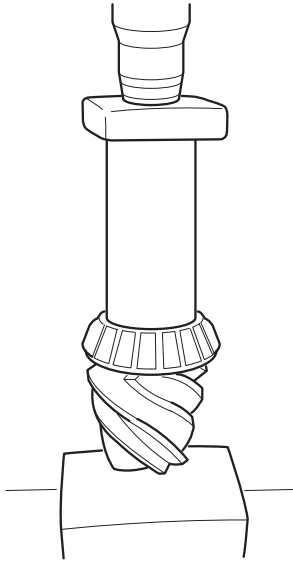

**⚠ IMPORTANT:** To prevent bearing damage, use suitable sleeve that only contacts inner race of bearing cone.

2. Install preselected bearing spacer.

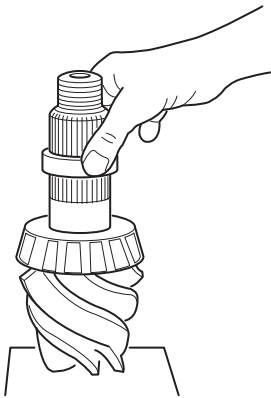

3. Press inner and outer bearing cups into the carrier until seated. Use a feeler gage (0.0015" [0.038 mm] approximately) to make sure that bearing cups are fully seated in bearing bores. Apply lubricant to both cup and cone.
4. Place carrier housing in press with the pinion supported by wood block (6"x6"x6" [152 x 152 x 152 mm]), so the inner pinion bearing is mated to the cone.

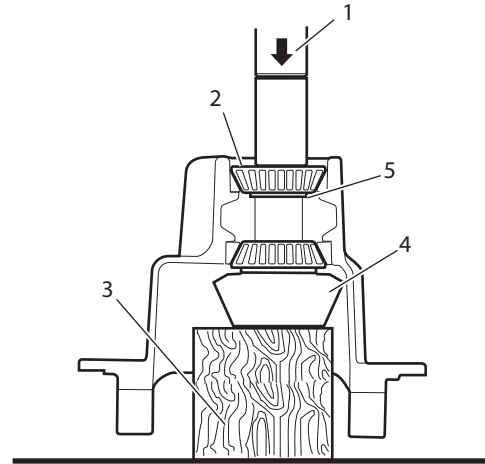

- |                          |                            |
|--------------------------|----------------------------|
| 1 — Press                | 4 — Drive pinion           |
| 2 — Outer pinion bearing | 5 — Bearing preload spacer |
| 3 — Wood block           |                            |

5. Press outer bearing onto pinion until completely seated. Rotate carrier during seating process.
6. Use torque multiplier and torque pinion nut to 710-1040 lbs. ft. (848-1410 N•m).

7. Measure torque to rotate the pinion with an inch-pound torque wrench. Torque measurements should be taken every fourth (4th) revolution and should read between 34-42 in.lbs. of bearing preload.

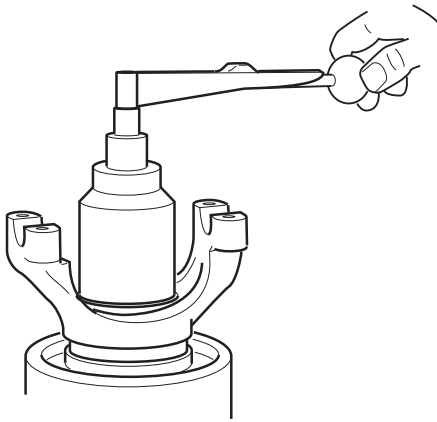

**Note:** If bearing preload does not fall within allowed limits, preload can be increased by using a thinner spacer and decreased by using a thicker spacer.

Always measure each spacer before assembly to ensure correct thickness.

8. Repeat process until torque to rotate is between 34-42 in. lbs. After proper preload is achieved, remove yoke and install new seal with proper service tool.

**CAUTION:** Do not use any silicone or permatex-type bore sealant with this seal.

9. Remove the new seal from its package and install with the proper driver: R-Pinion-Use drive #126917 only

**WARNING:** Due to the resiliency of the plastic driver, hammer rebound may occur when the seal is seated. Keep clear of the hammer rebound path!

10. Handle the seal by its outside diameter avoiding any contact with the seal lips. During installation, use the proper driver to make sure that the seal is mounted properly.

11. Use a rubber mallet to drive the seal tool in until the flange bottoms on the housing cover bore face. The flange will locate the seal at the proper depth.

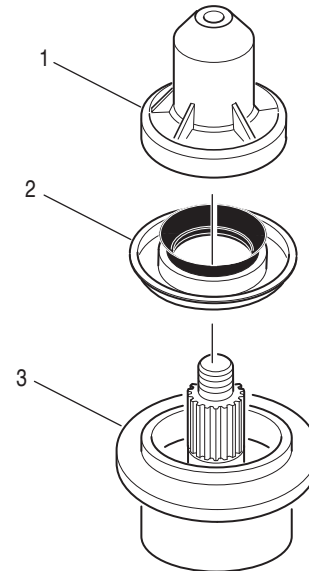

- 1 — Seal Driver
- 2 — Oil Seal
- 3 — Pinion Cage

12. Install end yoke.

**Note:** Dana Spicer recommends that new torque prevailing nuts be used.

13. Use torque multiplier and torque pinion nut to 710-1040lbs. ft. (848-1410N•m).

Wheel Differential

Wheel Differential Assembly

Parts Exploded View

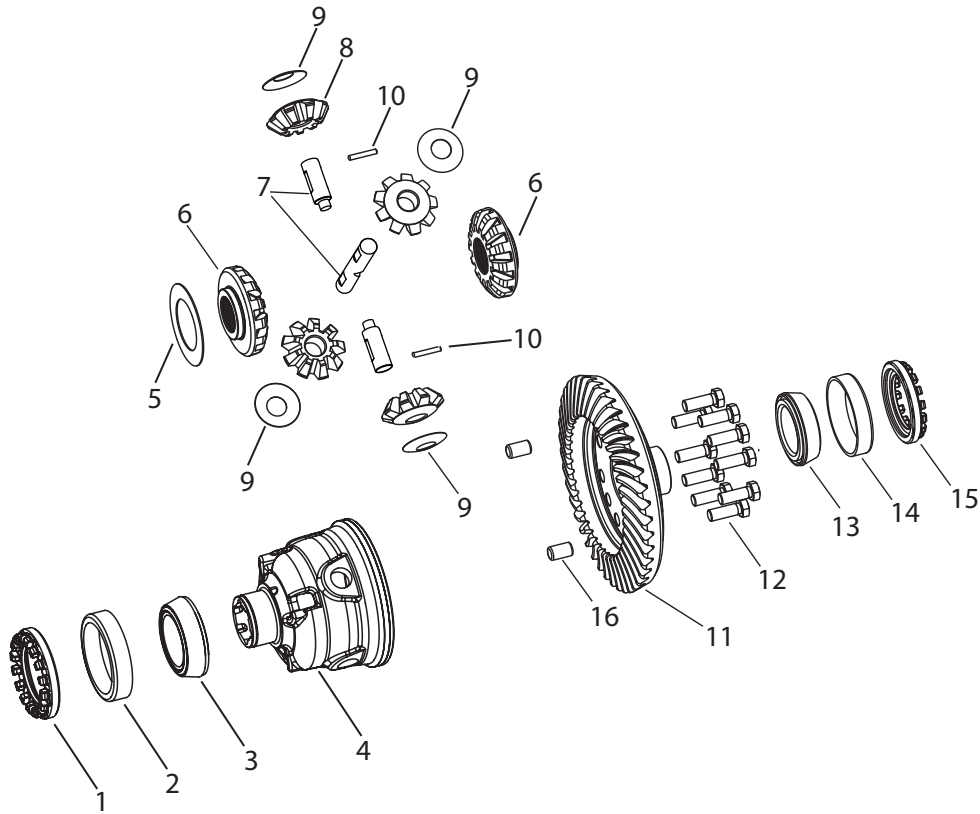

- 1 — Diff. case bearing adjuster
- 2 — Diff. bearing cup
- 3 — Diff. case bearing cone
- 4 — Differential case
- 5 — Side gear thrust washer
- 6 — Side gear
- 7 — Differential shaft
- 8 — Side pinion

- 9 — Side pinion thrust washer
- 10 — Pin
- 11 — Ring gear
- 12 — Ring gear bolt
- 13 — Ring gear bearing cone
- 14 — Ring gear bearing cup
- 15 — Ring gear bearing adjuster
- 16 — Locating dowels

## Disassemble, Overhaul, and Assemble Wheel Differential

### Disassemble Wheel Differential

**⚠ IMPORTANT:** Do not press on the wheel differential shaft to free the ring gear from the case. Pressing on the wheel differential shaft may cause it to bend and/or fatigue.

1. Remove cap screws fastening ring gear to differential case.

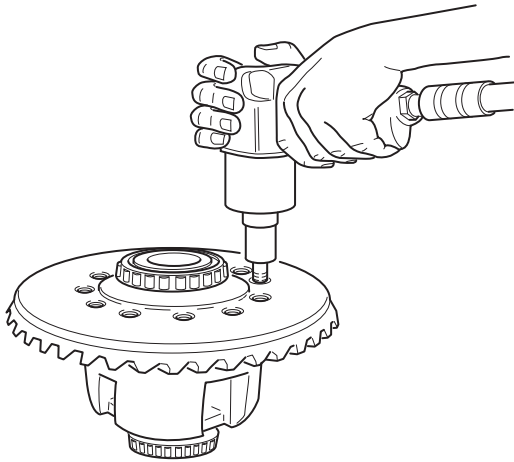

2. The ring gear to differential case interface is a press fit. Place the assembly in a press with the case facing downward. Support the assembly on either side of the ring gear. Thread a cap screw back into one of the case holes by hand. Press down on the head of the cap screw, you may need to press in more than one position to free the ring gear from the case.

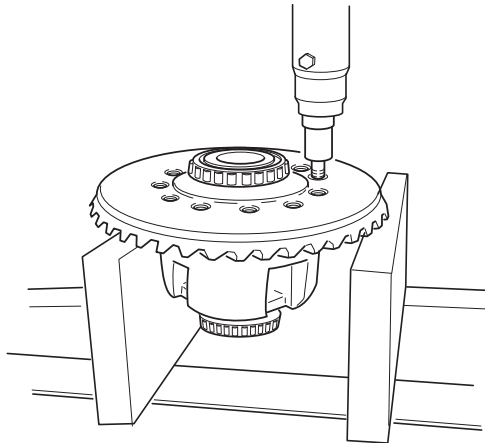

**⚠ CAUTION:** The differential case and gears will fall after separation. Support the case so that it will not cause damage to the differential or bodily injury.

3. Remove the outer side gear.

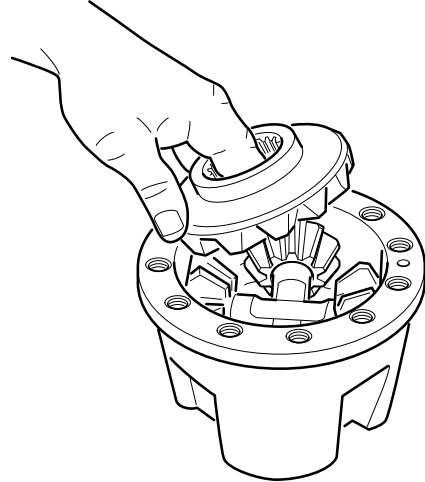

4. Remove the differential shaft locking pins by turning the differential case opening facing down. Use a hammer to lightly tap on the side of the case to free the locking pins.

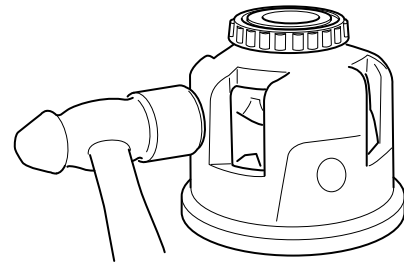

5. The locking pins are slip fit and should fall from the case easily.

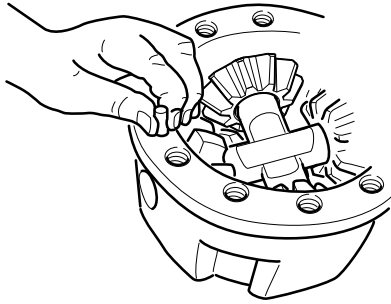

6. Remove the half shafts first and then remove their side pinions and thrust washers.

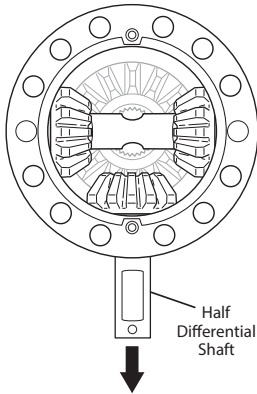

7. Remove the full shaft, side pinions and thrust washers.

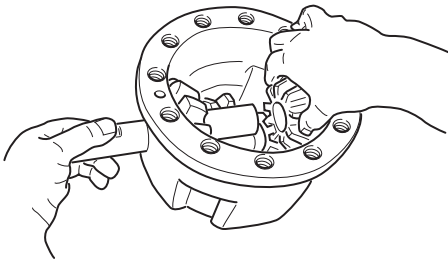

8. Remove inner side gear and thrust washer.

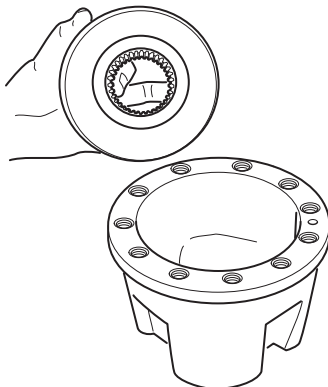

9. Remove bearing cones from ring gear and differential case in two steps:

a. Mount puller vertically to split bearing. This action will start moving the bearing off case and gear.

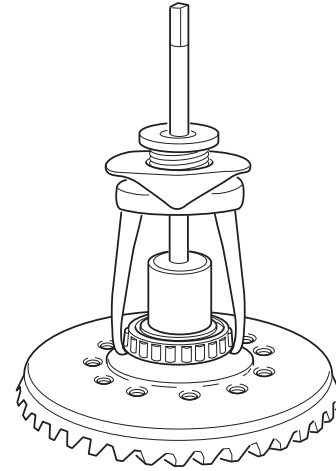

b. Mount puller horizontally to remove cone.

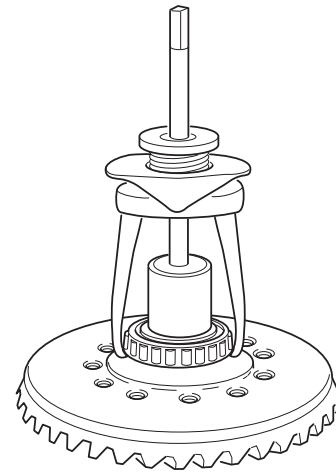

## Assemble Wheel Differential

10. Press new bearing cone on the differential case.

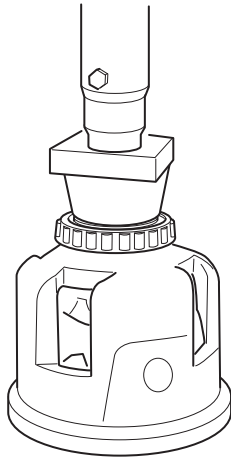

11. Place thrust washer on the side gear. Lubricate both sides of the thrust washer before installing.

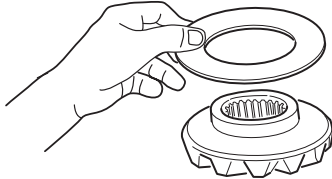

12. Install the side gear and thrust washer in the differential case.

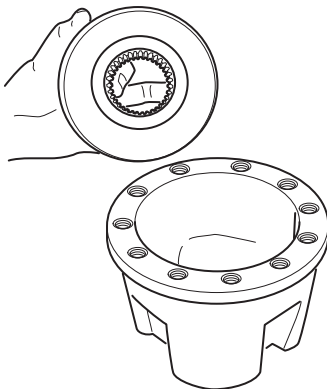

13. Start the full differential shaft into the shaft bores in the case that does not have a locking pin hole.

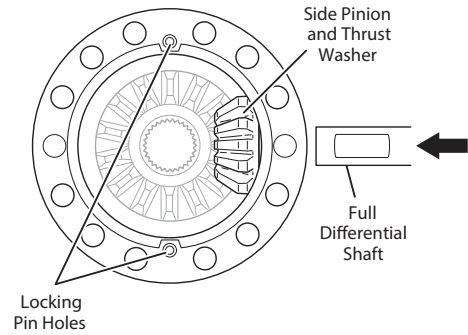

14. Install a side pinion and thrust washer and push the shaft through the side pinion.

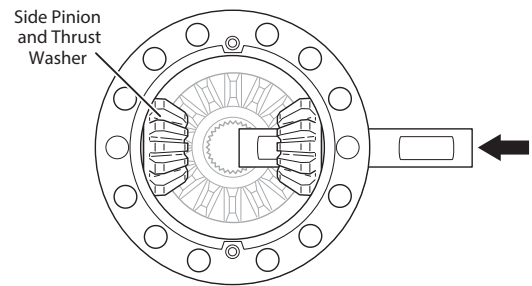

15. Install the side pinion and thrust washer to the other side of the full shaft.

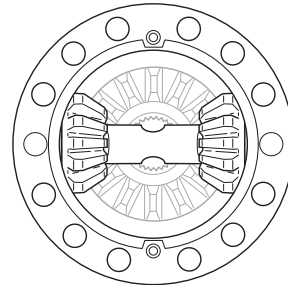



16. Install a side pinion and thrust washer on the half shaft side.

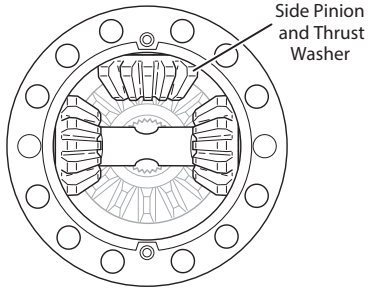

17. Install the half shaft so that the pin is facing upward and push it in until it stops.

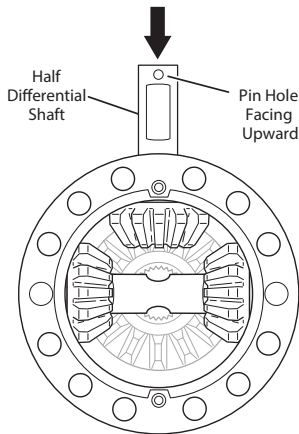

18. The end of the half shaft should fit into the slot of the full shaft at the same time as the hole in the case lines up with the hole in the half shaft.

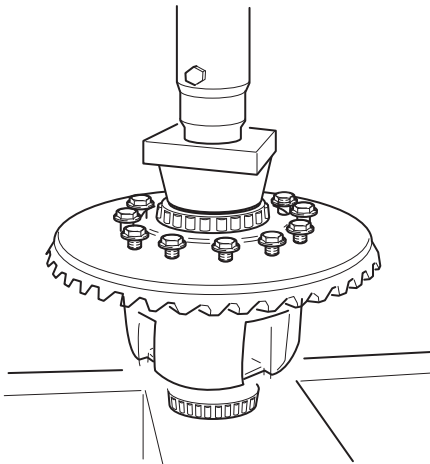

19. Install the locking pins to both sides of the differential case.

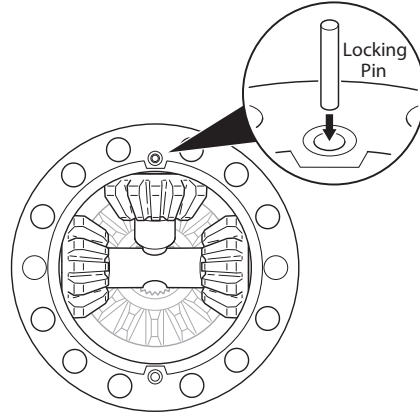

20. Install outer side gear.

**Note:** No thrust washer is used at this location.

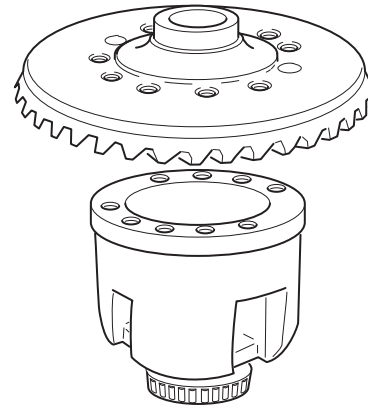

21. Lower the ring gear onto the case assembly aligning the locking dowels.

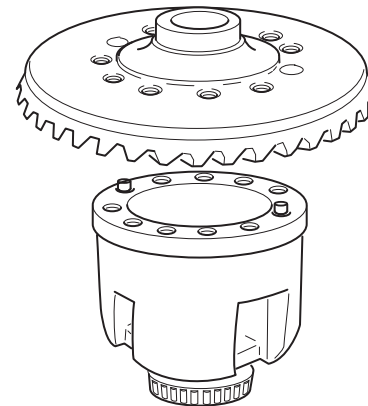

22. Install and hand-tighten all new ring gear cap screws

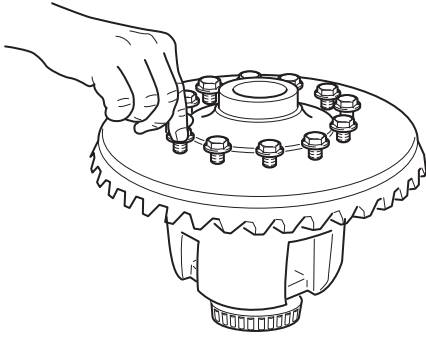

23. The interface of the ring gear to differential case is a press fit. Put the assembly in a press with the ring gear facing upward. Make certain that the ring gear is flush and square to the differential case before pressing. Press until ring gear bottoms out on the case.

**⚠ IMPORTANT: DO NOT** use the cap screws to draw the ring gear into place. Only use a press.

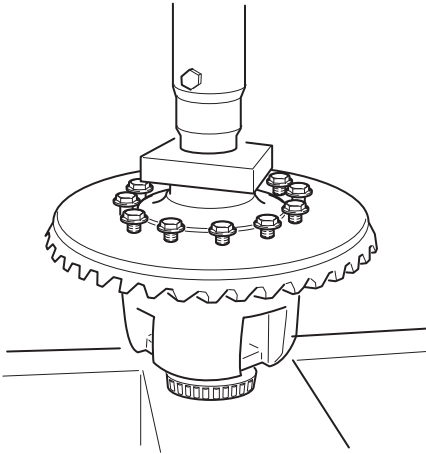

24. Press new ring gear bearing cone.

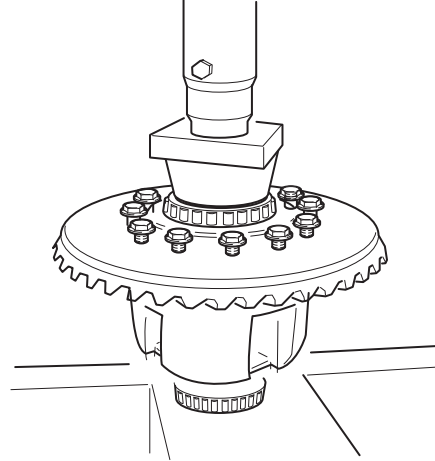

**⚠ IMPORTANT:** When pressing differential case bearing cones, note that the bearing is beyond flush with the top of the case. The cone must be fully seated. To prevent bearing damage, use suitable sleeve that only contacts the inner race of the cone. A used bearing race would be a suitable tool. This tool should have a slit cut if the ID is the same as the bearing boss OD.

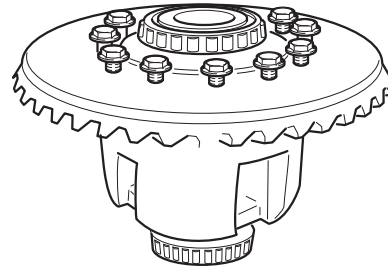

25. Tighten and torque ring gear cap screws in an alternating pattern. Torque to 435-465 lbs. ft. (589-630 N•m).

## Forward Carrier

### Forward Carrier – Assembly

1. Using a chain hoist and the proper lift tool, lift the ring gear and wheel differential assembly from the carrier.

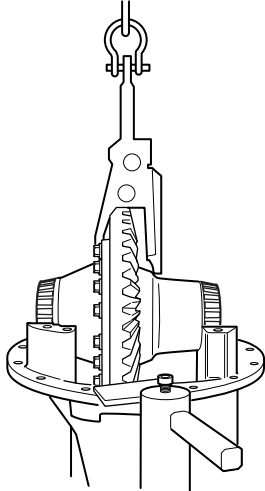

2. Apply a thin coat of oil to both wheel differential bearings.

3. Starting on the flange half side, install the bearing cup by using a long screw driver to lift the case assembly to make alignment easier.

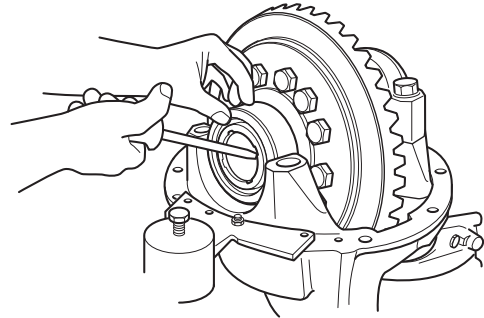

4. Now install the bearing adjuster. It's important to make sure the adjuster is installed squarely to the bearing cup.

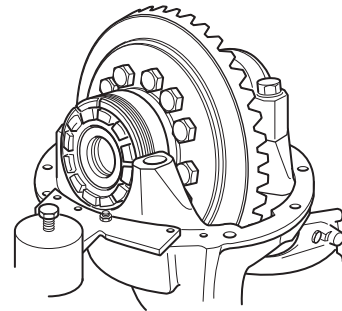

5. Back the bearing adjuster off one full turn to allow movement when installing the plain half bearing cup and adjuster.

6. Again with a screw driver, lift the differential case so plain half bearing cup can be installed.

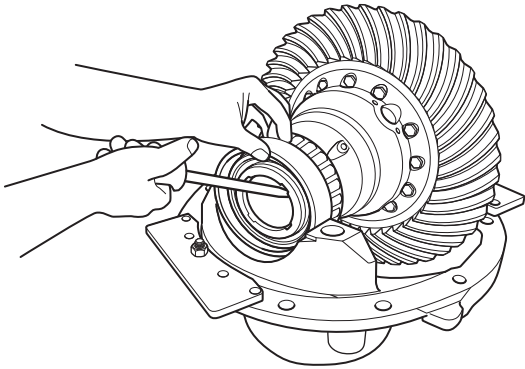

7. Now install the plain half bearing adjuster. Make sure the adjuster is square to the bearing cup.

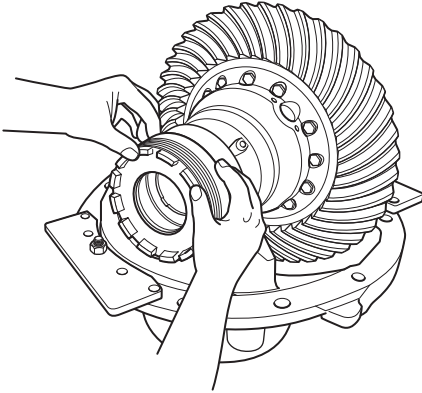

8. We can now set a "rough" backlash. With the plain half adjuster loose, turn the flange half adjuster so that the ring gear is moving in the direction of the pinion gear. Keep adjusting the flange half bearing adjuster until the ring gear contacts the pinion gear.
9. Now back the flange half adjuster off three notches of the bearing adjuster.

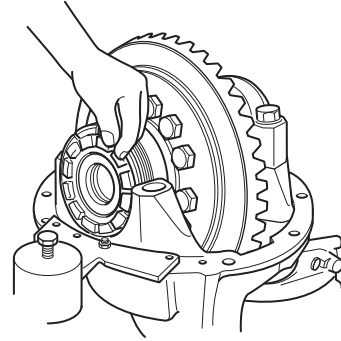

**10.** Now turn the plain half adjuster inward until you feel resistance on the adjuster. Continue to rotate the adjuster until the bearing cup just starts to rotate, stop. This is your “zero” bearing preload setting.

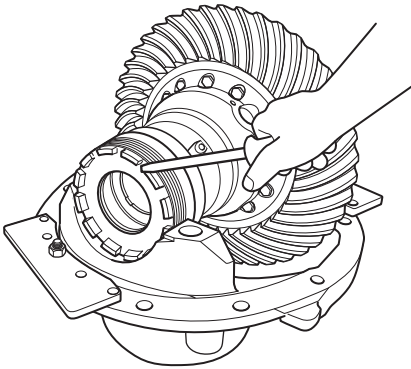

**11.** Tighten the bearing adjust two additional notches to create the proper bearing preload.

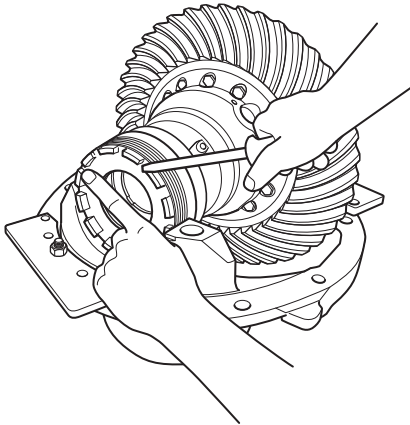

**12.** With a dead blow hammer seat each of the bearing adjusters.

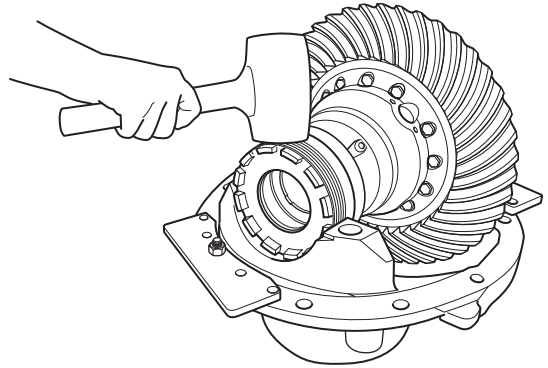

**13.** Mount the base of a dial indicator to the flange of the carrier.

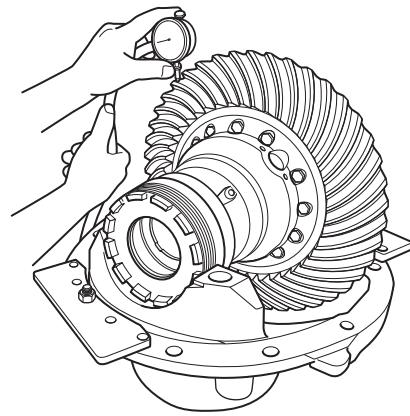

- 14. Place the tip of the indicator to the drive side heel of a ring gear tooth.
- 15. Record the actual backlash. Remember this is a rough lash.

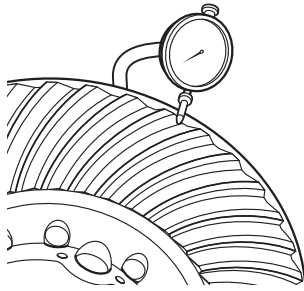

- 16. Now we can make our final backlash adjustments. The backlash specification for this axle model is 0.008" – 0.018". We want to set the backlash at 0.012" – 0.013" for new gearing. If the backlash has to increase in size the ring gearing must move away from the pinion. Each notch in the adjuster equals 0.003" – 0.004" of backlash.

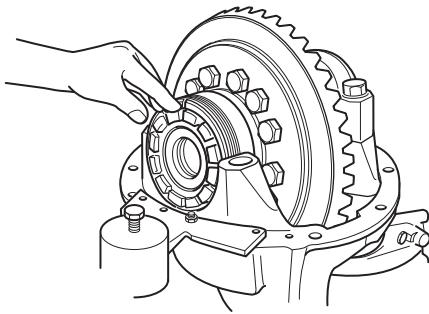

- 17. Start by backing off the bearing adjuster on the side that the gear set needs to move. Example: To increase the backlash, back off the flange half adjuster first. To decrease the amount of backlash, back off the plain half bearing adjuster first.

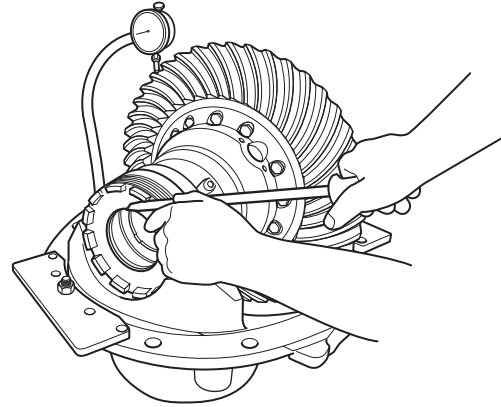

**⚠ IMPORTANT:** Remember we just set our bearing preload at two notches. When you back off one of the adjusters you must tighten the opposite adjuster the same number of notches.

18. With the backlash set at 0.012" – 0.013", install the flange half and plain half bearing cups.

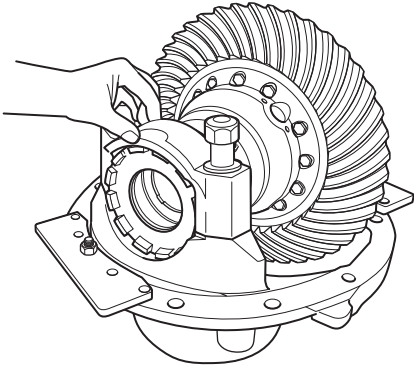

19. Snug the bolts down with an impact gun.

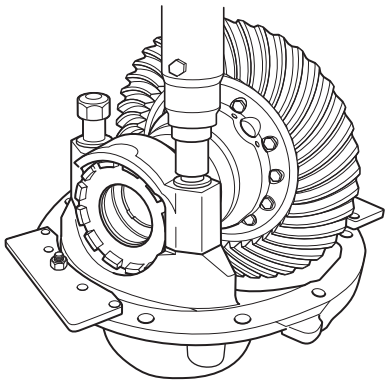

20. The backlash must be remeasured at this time. If the backlash did not remain at 0.012" – 0.013" the cups should be removed and the backlash must be readjusted. This process must be repeated until the specified backlash is achieved with the bearing cups installed and torqued to Dana specifications.

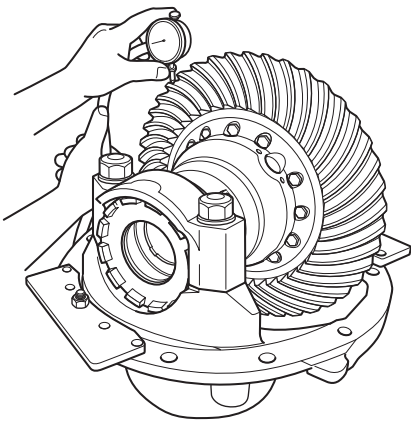

## Measure Ring Gear Runout

### Measure Ring Gear Total

1. Measure ring gear total radial runout. (Indicator reading should not exceed 0.010" [.25 mm]).

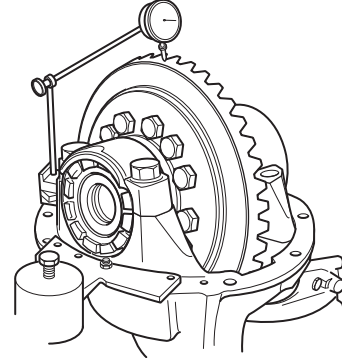

2. Measure ring gear total backface runout. (Indicator reading should not exceed 0.010" [.25 mm]).

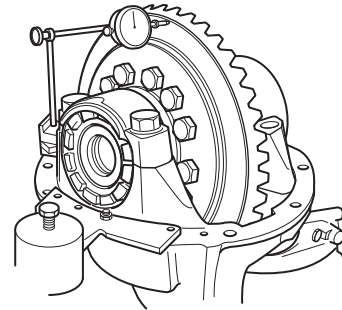

## Wheel Differential

### Adjust Ring and Pinion Tooth Contact Pattern

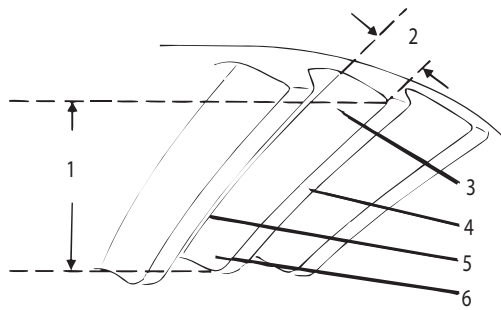

- |                 |              |
|-----------------|--------------|
| 1 — Face width  | 4 — Top land |
| 2 — Tooth depth | 5 — Root     |
| 3 — Heel        | 6 — Toe      |

1. Identify if new or used gearing.
2. Check tooth contact pattern (new or used gearing).

### New Gearing - Correct Pattern

- Paint six ring gear teeth 180° apart and roll the gear to obtain a contact pattern. The correct pattern is slightly below center on the ring gear tooth with lengthwise contact up off the toe. The length of the pattern in an unloaded condition is approximately one-half (1/2) to two-thirds (2/3) of the ring gear tooth in most models and ratios.
- The pattern could vary in length and should cover half (1/2) of the tooth or more (face width). The pattern should be evenly centered between tooth top land and root and should be up off the tooth toe.

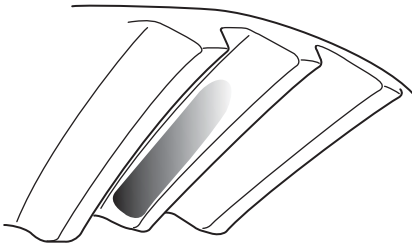

### Adjust Ring Gear Position (Backlash)

If the ring gear pattern shows incorrect face width contact, change backlash by adjusting the ring gear.

If the pattern is too close to the edge of the tooth toe, move the ring gear away from the pinion to increase backlash.

### Used Gearing - Correct Pattern

- Used gearing will not usually display the square, even contact pattern found in new gear sets. The gear will normally have a “pocket” at the heel end of the gear tooth. The more use a gear has had, the more the line becomes the dominant characteristic of the pattern.
- Adjust used gear sets to display the same contact pattern observed before disassembly. A correct pattern is up off the toe and centers evenly along the face width between the top land and root. Otherwise, the length and shape of the pattern are highly variable and is considered acceptable as long as it does not run off the tooth at any point.

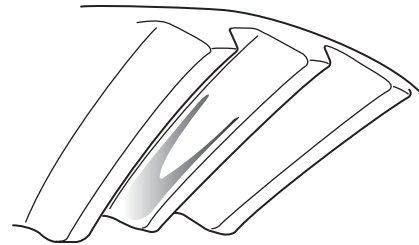

- 1 — Pattern along the face width could be longer



ring gear away from the pinion to increase backlash.

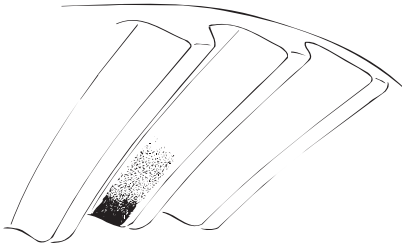

1. Loosen the bearing adjuster on the teeth side of the ring gear several notches.
2. Loosen the opposite adjuster one notch.
3. Return to adjuster on teeth side of the ring gear and tighten adjuster until it contacts the bearing cup.
4. Continue tightening the same adjuster two (2) or three (3) notches and recheck backlash. If the pattern is concentrated at the heel (too far up the tooth), move the ring gear toward the pinion to decrease backlash.

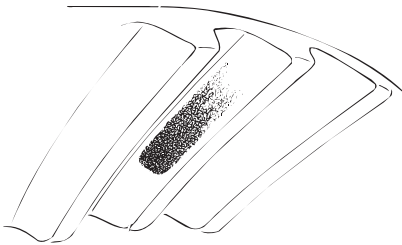

5. Loosen the bearing adjuster on the teeth side of the ring gear several notches.
6. Tighten the opposite adjuster one notch.
7. Return to adjuster on teeth side of ring gear and tighten adjuster until it contacts the bearing cup.
8. Continue tightening the same adjuster two (2) or three (3) notches and recheck backlash.

Seals

Service Kit 217414

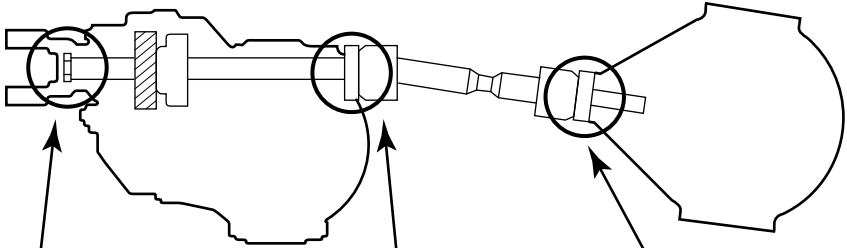
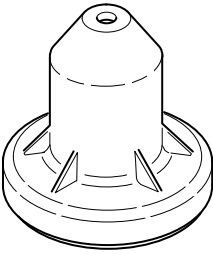
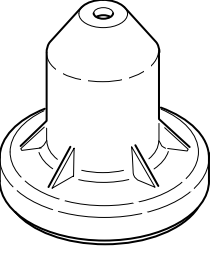
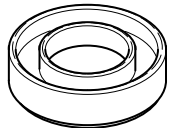
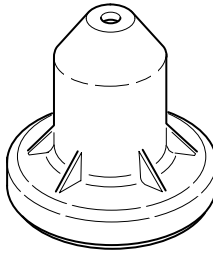
	D-Input	D-Output	R-Pinion
Location			
Tool	 126917	 126917 +  128706	 126917

## Lubrication

### General Lubrication Information

The ability of a drive axle to deliver quiet, trouble-free operation over a period of years is largely dependent upon the use of good quality gear lubrication in the correct quantity. The most satisfactory results can be obtained by following the directions contained in this manual.

The following lubrication instructions represent the most current recommendations from Dana.

### Approved Lubricants

**General**—Gear lubrications acceptable under military specification (MILSPEC) MIL-L-2105D (Lubricating Oils, Gear, Multipurpose) are approved for use in Spicer Drive Axles. The MIL-L-2105D specification defines performance and viscosity requirements for multigrade oils. It supersedes both MIL-L-2105B, MIL-L-2105C and cold weather specification MIL-L-10324A. This specification applies to both petroleum-based and synthetic based gear lubricants if they appear on the most current “Qualified Products List” (QPL-2105) for MIL-L-2105D.

**Note:** The use of separate oil additives and/or friction modifiers are not approved in Spicer Drive Axles.

**Synthetic based**—Synthetic-based gear lubricants exhibit superior thermal and oxidation stability, and generally degrade at a lower rate when compared to petroleum-based lubricants. The performance characteristics of these lubricants include extended change intervals, improved fuel economy, better extreme temperature operation, reduced wear and cleaner component appearance. The family of Spicer gear lubricants represents a premium quality synthetic lube which fully meets or exceeds the requirements of MIL-L-2105D. These products, available in both 75W-90 and 80W-140, have demonstrated superior performance in comparison to others qualified under the MILSPEC, as demonstrated by extensive laboratory and field testing. For a complete list of Spicer approved synthetic lubricants, contact your local Dana representative. See back cover of this manual for appropriate phone number.

**Makeup Lube**—Maximum amount of non-synthetic makeup lube is 10%.

### Recommendations for Viscosity/Ambient Temperature

The following chart lists the various SAE grades covered by MIL-L-2105D and the associated ambient temperature range from each. Those SAE grades shown with an asterisk (\*) are available in the Spicer family of synthetic gear lubricants.

The lowest ambient temperatures covered by this chart are -40°F and -40°C. Lubrication recommendations for those applications which consistently operate below this temperature range, must be obtained through Dana by contacting your local Dana representative.

Grade	Ambient Temperature Range
75W	-40°F to -15°F (-40°C to -26°C)
75W-80	-40°F to 80°F (-40°C to 21°C)
75W-90*	-40°F to 100°F (-40°C to 38°C)
75W-140	-40°F and above (-40°C and above)
80W-90	-15°F to 100°F (-26°C to 38°C)
80W-140*	-15°F and above (-26°C and above)
85W-140	10°F and above (-12°C and above)

\* Available in the Spicer family of synthetic gear lubricants

**Lube Change Intervals**

This product combines the latest manufacturing and part washing technology. When filled with a Spicer approved synthetic lubricant at the factory, the initial drain is not required.

**Change the lubricant within the first 5,000 miles of operation when not using a Spicer approved synthetic lubricant in either a new axle or after a carrier head replacement.**

Base subsequent lubricant changes on a combination of the following chart and user assessment of the application and operating environment.

**Severe Service Lubrication Change Intervals**

Severe service applications are those where the vehicle consistently operates at or near its maximum GCW or GVW ratings, dusty or wet environments, or consistent operation on grades greater than 8%. For these applications, the ON/OFF HIGHWAY portion of the chart should be used. Typical applications are construction, logging, mining and refuse removal.

**Note:** Clean metallic particles from the magnetic filler plug and drain plugs. Clean or replace the breather yearly to avoid lube contamination due to water ingestion.

Synthetic or Mineral	Lubricant	SAE	Change Interval for Line Haul	Change Interval for Vocational
Synthetic*	SHAES-256	SAE 75W-90	500,000 miles (800,000 Km) or 5 years	120,000 miles (193,000 Km) or 1 year
Synthetic**	SHAES-256	SAE 75W-90, 75W-140	250,000 miles (400,000 Km) or 3 years	60,000 miles (96,500 Km) or 1 year
Mineral Base	MIL-L-2105E/J02360, API GL-5 Gear Oil, MIL-PRF-2105E	75W, 75W-90, 75W-140, 80W-90, 85W-140	120,000 miles (193,000 Km) or 1 year	60,000 miles (96,500 Km) or 1 year

\* Axles using LMS wheel end system

\*\* Axles using adjustable wheel bearing system

## Change Lube

### Drain

Drain when the lube is at normal operating temperature (150°–200°F). It will run freely and minimize the time necessary to fully drain the axle, this ensures the axle is flushed.

Unscrew the magnetic drain plug on the underside of the axle housing and allow the lube to drain into a suitable container.

**Note:** Dispose of all used lubricants properly by following disposal methods approved for mineral or synthetic based oils.

After initial oil change, inspect drain plug for large quantities of metal particles. These are signs of damage or extreme wear in the axle. Clean the drain plug and replace it after the lube has drained completely. Inspect breather for clogging or corrosion. Clean or replace as necessary.

### Fill

#### Front Axle

- a. With vehicle on level ground, remove the filler hole plug from the axle housing cover and fill the axle with approved lubricant until level with the bottom of the hole.

#### Rear Axle

- a. Remove the filler hole plug from the axle housing cover and fill the axle with the approved lubricant until level with the bottom of the hole.
- b. If wheel ends were removed, follow instructions in wheel end servicing [page 83](#).

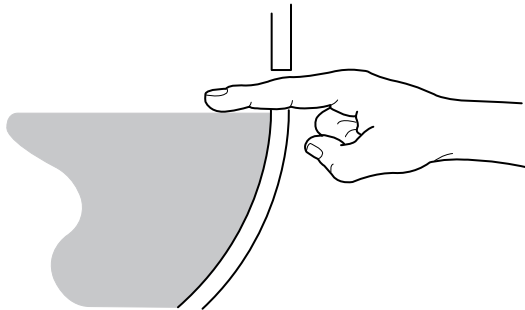

*Correct lube level at bottom of filler hole.*

Always use the filler hole as the final reference. If lube is level with the bottom of the hole, the axle is properly filled.

**Note:** Lube fill capacities (see chart) are basic guidelines and will vary based on the angle the axle is installed in a particular chassis. Torque fill plug to 40–60 lbs. ft. (54–82 N•m).

**TIP:** The axle can be filled through the axle housing breather hole. Fill until lube level is even with the bottom of filler hole in axle housing rear cover.

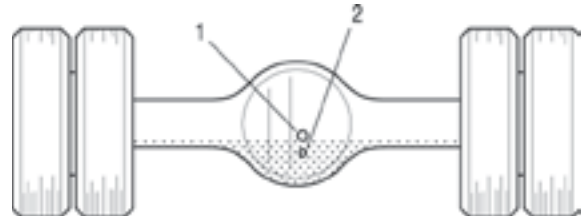

- 1 — With axle on level surface, fill housing with oil to bottom of plug
- 2 — Temperature sensor mounting hole

Wheel End Seal

Wheel End Seal - Parts Exploded View

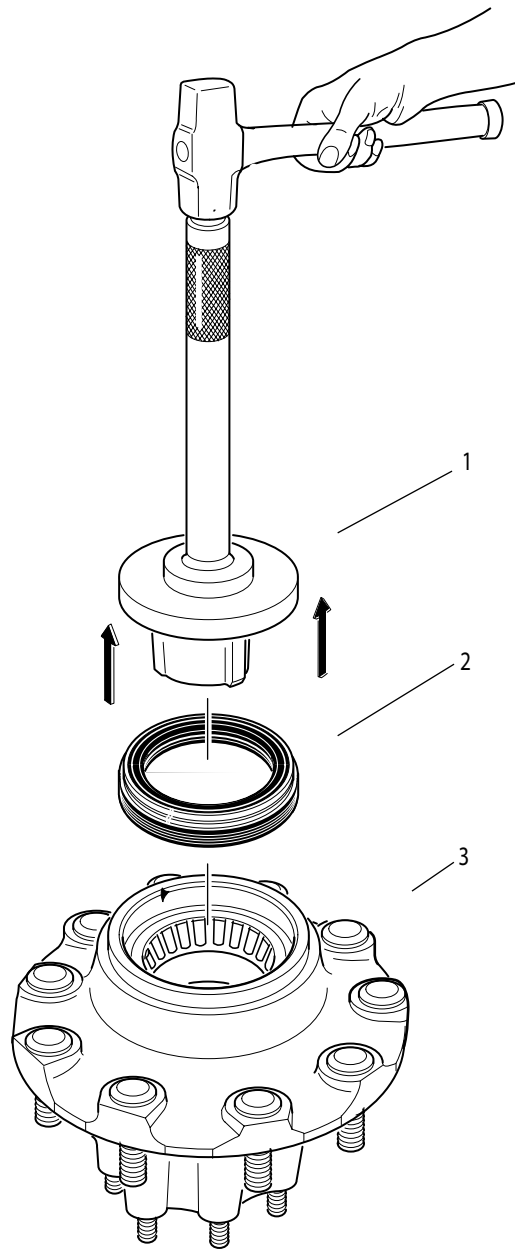

- 1 — Installation tool
- 2 — Seal
- 3 — Rear hub

## Disassemble and Overhaul Wheel End Seal

 **WARNING:** Never work under a vehicle supported by only a jack. Always support vehicle with stands. Block the wheels and make sure the vehicle will not roll before releasing the brakes.

 **IMPORTANT:** Wheel end seals can be easily damaged during handling. Leave the seal in its package until installation to prevent damage or contamination.

1. Remove outer bearing and wheel.
2. Remove oil seal.
3. Remove inner bearing.
4. Remove old wear sleeve (2-piece design only) with a ball peen hammer and discard.

 **IMPORTANT:** Do not cut through the old wear sleeve. Damage to the housing may result.

5. Inspect spindle journal and hub bore for scratches or burrs. Recondition with an emery cloth as required.

**Note:** Deep gouges can be repaired by filling gouge with hardening gasket cement and smoothing with emery cloth.

6. Clean hub cavity and bearing bores before reassembly. Be sure to remove contaminants from all recesses and corners.
7. Clean bearings thoroughly with solvent and examine for damage. Replace damaged or worn bearings.

 **IMPORTANT:** Always use the seal installation tool specified by the seal manufacturer. Using an improper tool can distort or damage the seal and cause premature seal failure.

## Install Wheel End Seal

1. Before installation, lubricate the following with the same lubricant used in the axle sump.

- Inner bearing
- Wheel seal (follow the directions provided by the seal supplier)

2. Place seal on installation tool.

3. Drive seal with installation tool onto hub.

## Verify Wheel End-play Procedure

Verify that end-play meets specification using a dial indicator. An indicator with 0.001" (0.03 mm) resolution is required. Wheel end play is the free movement of the tire and wheel assembly along the spindle axis. Correct end-play is 0.001"– 0.005" (0.025–0.125 mm).

4. Attach a dial indicator with its magnetic base to the hub or brake drum as shown below:
5. Adjust the dial indicator so that its plunger or pointer is against the end of the spindle with its line of action approximately parallel to the axis of the spindle.
6. Grasp the wheel assembly at the 3 o'clock and 9 o'clock positions. Push the wheel assembly in and out while oscillating it to seat the bearings. Read bearing end-play as the total indicator movement.

**⚠ CAUTION:** If end-play is not within specification, readjustment is required.

## Adjust End-play with Tire and Wheel Assembly

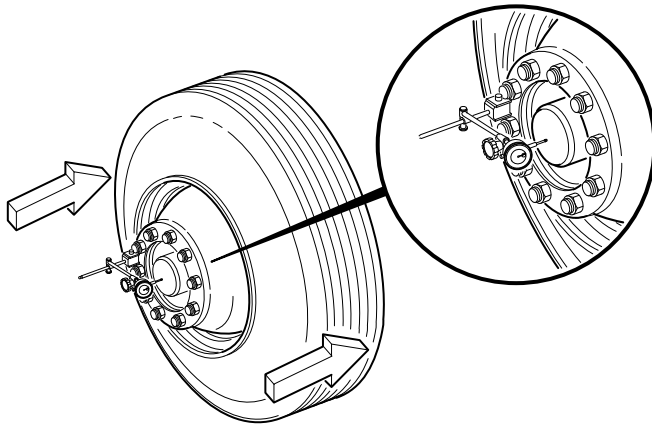

## Adjust End-play with Wheel Hub

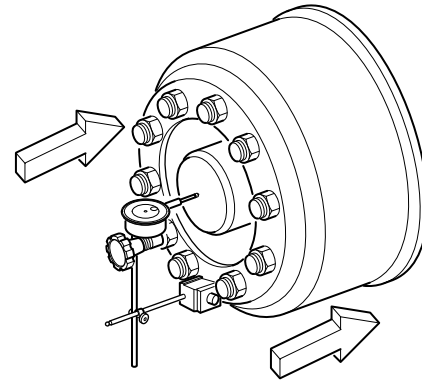

*With indicator mounted at bottom,  
Push / Pull at sides of drum*

## Readjust Wheel End-play Procedure

**Excessive End-play**—If end-play is greater than 0.005" (.127 mm), remove the outer nut and pull the lock washer away from the inner nut, but not off the spindle. Tighten the inner nut to the next alignment hole of the dowel-type washer (if used). Reassemble the washer and re-torque the outer nut. Verify end-play with a dial indicator.

**Insufficient End-play**—If end-play is not present, remove the outer nut and pull the lock washer away from the inner nut, but not off the spindle. Loosen the inner nut to the next adjustment hole of the dowel-type washer (if used). Reassemble the washer and re-torque the outer nut. Verify end-play with a dial indicator.

**Fine Tuning the End-play**—If, after performing the readjustment procedures, end-play is still not within the 0.001" – 0.005" (0.025 – 0.127 mm) range, disassemble and inspect the components. If parts are found to be defective, replace the defective parts, reassemble and repeat wheel bearing adjustment procedure. Verify end-play with a dial indicator.



## Lubricate Wheel End

**⚠ IMPORTANT:** Before operating the axle, the wheel hub cavities and bearings must be lubricated to prevent failure.

When wheel ends are serviced, follow Dana's wheel end lubrication procedure before operating the axle.

Dana axles may be equipped with either of two wheel end designs:

- Wheel ends **with** an oil fill hole.
- Wheel ends **without** an oil fill hole.

### Wheel Ends with an Oil Fill Hole

7. Rotate the wheel end hub until the oil fill hole is up.
8. Remove the oil fill plug.
9. Pour 1/2 pint of axle sump lubricant into each hub through the wheel end fill hole.
10. Install oil fill plug and tighten to specified torque.

Wheel End with Oil Fill Hole

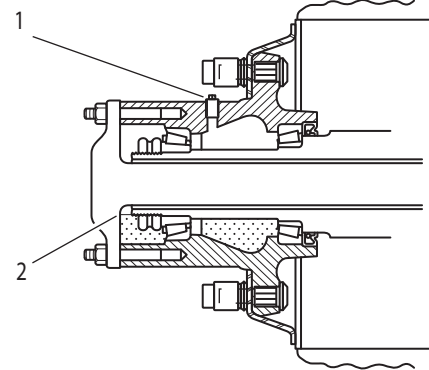

Wheel End without Oil Fill Hole

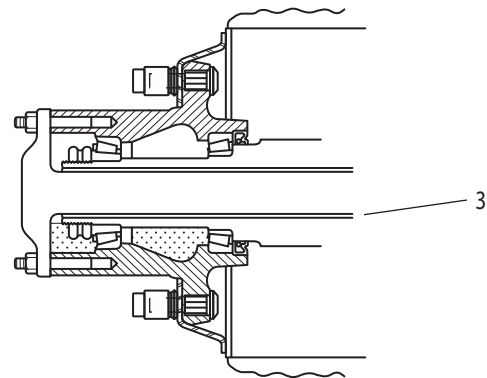

- 1 — Wheel end oil fill hole
- 2 — Proper lubricant level
- 3 — Lubricant flow from sump

### Vehicle Towing

#### Proper Vehicle Towing

##### Without Wheel Differential Lock

Lift the drive wheels completely off of the ground or damage will occur.

 **WARNING:** Do not lift the front wheels (non-drive wheels). This alters the oil's position in the drive axle, draining it away from the drive pinion and its bearings. If the pinion is rotated under these conditions for any period of time, bearings will overheat resulting in axle damage or failure.

If it is impossible to lift the drive wheels, remove all axle shafts to prevent gear rotation and cap the wheel hubs to prevent loss of lubricant and a possible road hazard. See the following section Proper Vehicle Towing with Wheel Differential Lock for removal procedure.

## Theory of Operation

### Power Divider Operation (Power Flow and Torque Distribution)

In operation, the power divider accepts torque from the vehicle driveline and distributes it equally to the two axles.

This assembly is of the two-gear design consisting of an input shaft, inter-axle differential, output shaft and two constant-mesh helical gears.

The inter-axle differential compensates for minor variations in speed between the two axles, the same way the wheel differential works between the two wheels of a single drive axle. This unit also acts as a central point in distribution of torque to the two axles.

The power divider also includes a driver-controlled, air-operated lockout. When lockout is engaged, it mechanically prevents inter-axle differentiation for better performance under poor traction conditions.

#### With Lockout Engaged (Inter-Axle Differential is Operating)

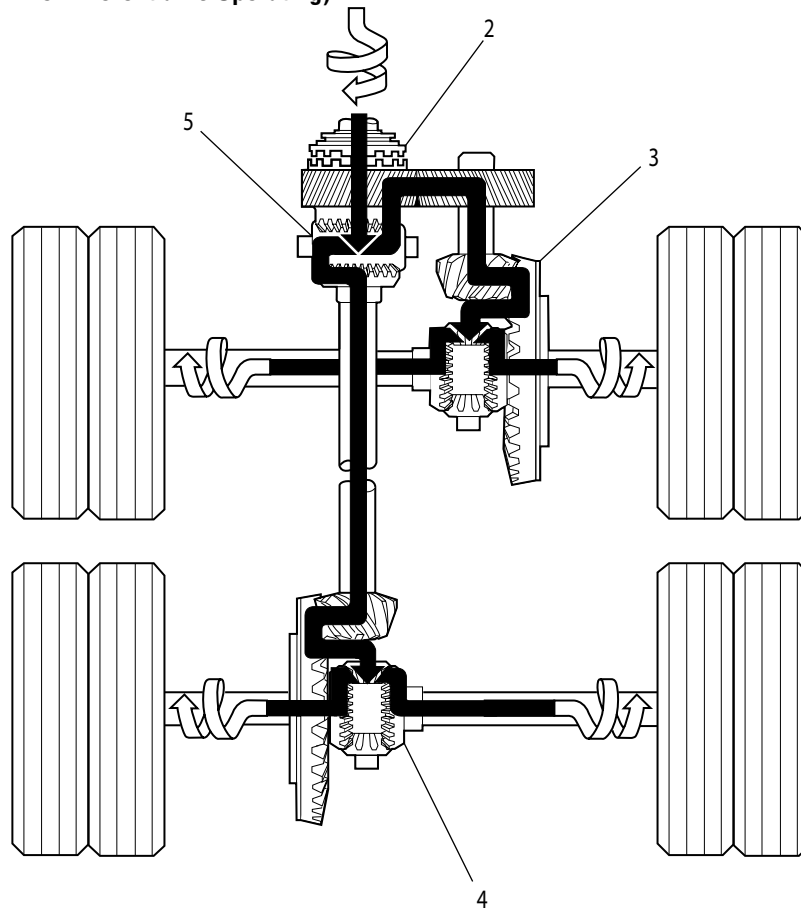

- 1 — Input torque
- 2 — Lockout disengaged
- 3 — Forward axle torque is transmitted from the helical side gear through the pinion helical gear, drive pinion, ring gear, wheel differential and axle shafts.

- 4 — Rear axle torque is transmitted from the output shaft side gear through the output shaft, inter-axle driveline, drive pinion, ring gear, wheel differential and axle shafts.
- 5 — Input torque (power flow) from the vehicle driveline is transmitted to the input shaft and the inter-axle differential spider. The differential distributes torque equally to both axles.

**With Lockout Engaged  
(Inter-Axle Differential is Not Operating)**

Lockout should only be engaged when both axles are rotating at the same speed. Operation should be limited to low-traction situations and should be disengaged when normal traction returns. Failure to do so will result in poor handling and damage to the axle components.

**Note:** Varied road surface conditions can result in unequal torque distribution between the two axle assemblies.

**CAUTION:** Prolonged operation with the lockout engaged can damage axle and driveline components.

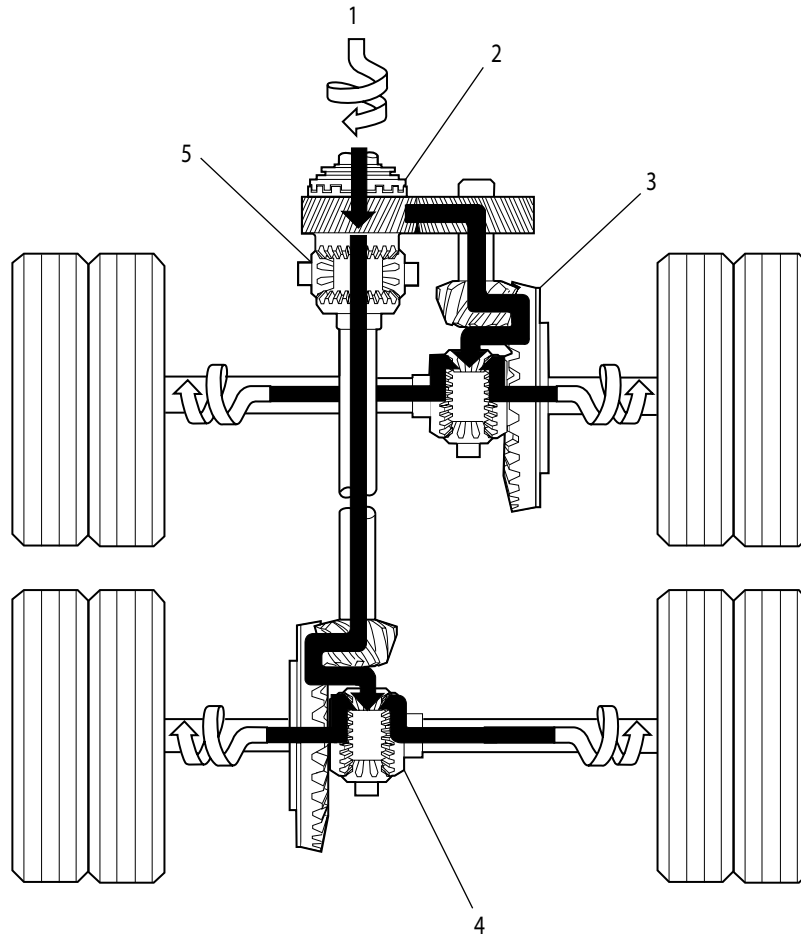

- 1 — Input torque
- 2 — Lockout engaged
- 3 — Forward axle torque is transmitted from the helical side gear through the pinion helical gear, drive pinion, ring gear, wheel differential and axle shafts.
- 4 — Rear axle torque is transmitted from the output shaft side gear through the output shaft, inter-axle driveline, drive pinion, ring gear, wheel differential and axle shafts.
- 5 — Input torque (power flow) from the vehicle driveline is transmitted directly to the helical side gear and the output shaft. A positive drive is provided to both axles for maximum traction under adverse road conditions.

### Operate Wheel Differential Assembly

The Dana wheel differential lock is driver-controlled and operated by a carrier mounted air-actuated shift unit. In operation, it positively locks the wheel differential to provide improved traction under adverse road conditions.

### Control Systems for Differential Lock

Two systems may be used to control the differential lock operation.

#### Transmission Low-Range Interlock Control System

The wheel differential is locked manually with the transmission in Low-Range. It is unlocked by the driver or unlocked when the transmission is shifted out of Low-Range.

**Note:** The interlock system is preferred for vehicles equipped with an air-shifted, Low-Range transmission. It is designed to ensure the differential lock is not left engaged (and to prevent accidental engagement) when transmission is in high range.

#### Direct Driver-controlled System

### Direct Driver-controlled System

The driver manually locks and unlocks the wheel differential, using a cab-mounted electric switch (or air valve). The following description assumes the system includes a cab-mounted electric switch and a solenoid valve as shown in the illustration. An air valve may be substituted for these components. Operation is as follows:

1. With control switch in the “unlock” position, the wheel differential functions normally.
2. When the control switch is placed in the “lock” position, the air supply solenoid valve opens and air pressure activates the shift cylinder. The shift fork is moved to engage the curvic clutches, which, in turn, lock the wheel differential.
3. When the control switch is placed in the “unlock” position, air pressure supply to the shift cylinder is shut off and air pressure is released from the cylinder. A compression spring moves the shift fork to disengage the curvic clutch and unlock the wheel differential.

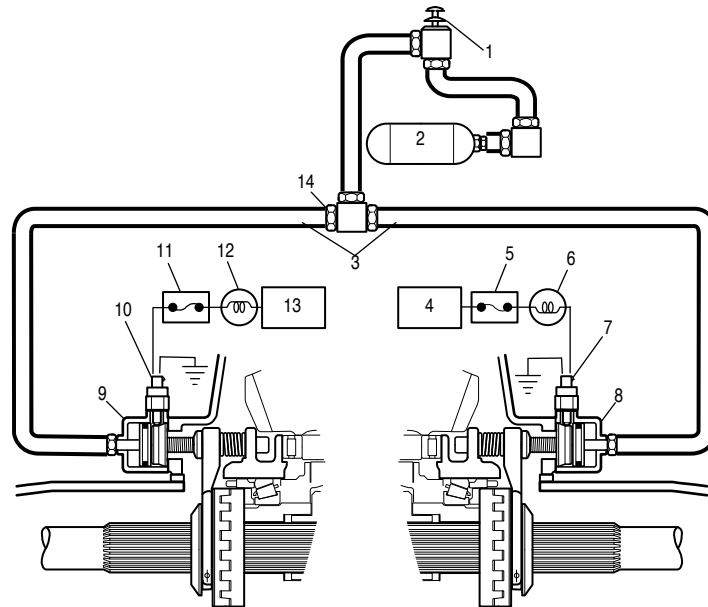

- |   |   |
|---|---|
| <ul style="list-style-type: none"> <li>1 — Cab-mounted control valve (plunger in—valve open)</li> <li>2 — Dry air supply tank 80–120 PSI</li> <li>3 — Preferably equal in length</li> <li>4 — Power supply</li> <li>5 — Fuse or circuit breaker</li> <li>6 — Indicator light or audible signal</li> <li>7 — Wheel differential lock indicator switch (part of axle assembly)</li> <li>8 — Rear axle wheel differential lock air shift cylinder (part of axle assembly)</li> <li>9 — Forward rear axle wheel differential lock air shift cylinder (part of axle assembly)</li> </ul> | <ul style="list-style-type: none"> <li>10 — Wheel differential lock indicator switch (part of axle assembly)</li> <li>11 — Indicator light or audible signal</li> <li>12 — Fuse or circuit breaker</li> <li>13 — Power supply</li> <li>14 — 66468 Quick release valve (optional) located on frame rail and within 10 feet of tubing from control valve</li> </ul> |
|---|---|

**Wheel Differential Lock**

The Dana Wheel Differential Lock is an optional feature for Dana Axles. In operation, it positively locks the wheel differential to provide improved traction under adverse road conditions.

The differential lock is driver-controlled through an electric switch or air valve mounted in the cab. The locking mechanism is air-operated to engage a mechanical clutch and lock the wheel differential. It is spring-operated to disengage the lock and permit the wheel differential to function normally.

The wheel differential lock consists of three major assemblies.

- **Shift Cylinder Assembly:** Operates a shift fork and push rod assembly.
- **Shift Fork and Push Rod Assembly:** Engages and disengages the differential lock curvic clutch assembly
- **Curvic Clutch Assembly:** Consists of a sliding clutch splined to a axle shaft and a fixed clutch which is splined to the differential case hub.

The differential lock also includes a selector switch (electric) which senses clutch engagement and sends an electrical signal to a cab mounted indicator light (or an audible signal device).

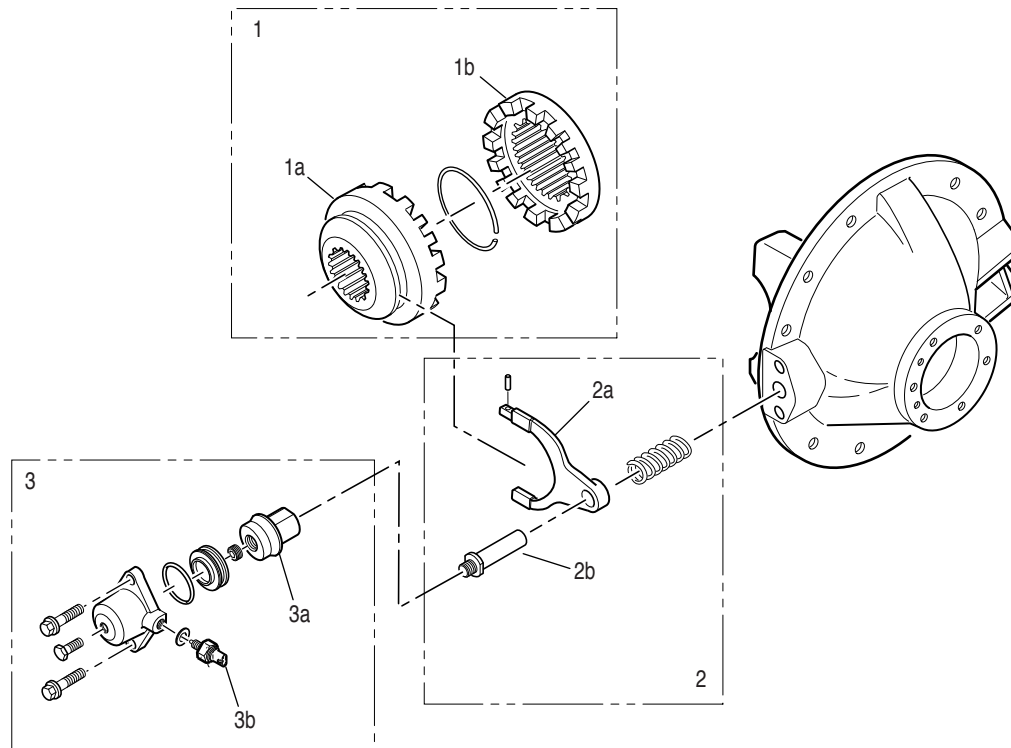

- 1** — Curvic clutch assembly
- 1a** - Sliding clutch
- 1b** - Fixed clutch
- 2** — Shift fork and push rod assembly
- 2a** - Shift fork
- 2b** - Pushrod
- 3** — Shift cylinder assembly
- 3a** - Piston driver
- 3b** - Selector switch

**Differential Lock Engaged**

Air pressure applied to the shift cylinder moves the piston, push rod, shift fork and the sliding curvic clutch engages the fixed curvic clutch.

The sliding clutch is splined to the axle shaft. The fixed clutch is splined to the differential case hub. Engaging the two clutches locks the wheel differential thus preventing wheel differential action.

**Differential Lock Disengaged**

When air pressure at the shift cylinder is released, a compression spring (mounted on the push rod) moves the push rod, shift fork and sliding clutch as an assembly. The sliding clutch moves out of engagement with the fixed clutch. The wheel differential is unlocked and operates normally.

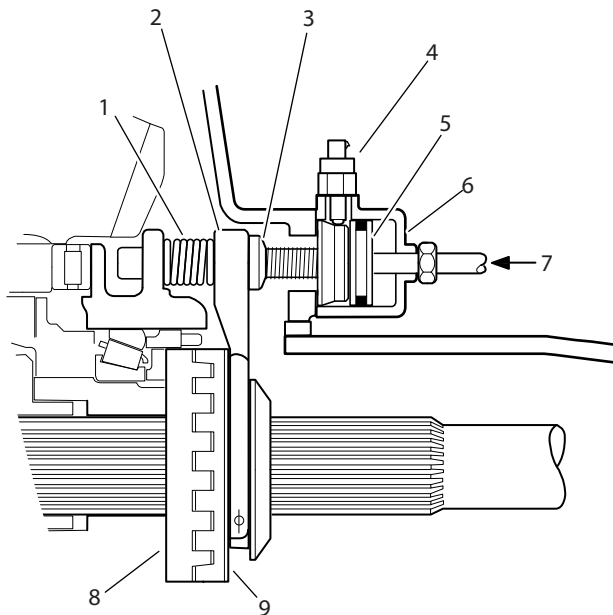

**Differential Lock Engaged**

- 1 — Spring is compressed
- 2 — Shift fork
- 3 — Push rod
- 4 — Selector switch
- 5 — Piston
- 6 — Shift cylinder
- 7 — Air pressure applied engages clutches
- 8 — Fixed clutch splined to differential case
- 9 — Sliding clutch splined to axle shaft

**Differential Lock Engagement Indicator**

Differential lock engagement is detected by a switch (electric) mounted on the differential carrier. An actuator, mounted in the piston cover, operates the switch.

When the shift fork moves to engage the differential lock, the push rod actuator moves away from the switch, allows the switch to close and send an electrical signal to turn on a cab-mounted indicator light (or an audible signal).

When the shift fork moves to disengage the differential lock, the compression spring also moves the push rod actuator to contact the switch. The switch is opened and turns off the cab-mounted indicator light (or the audible signal).

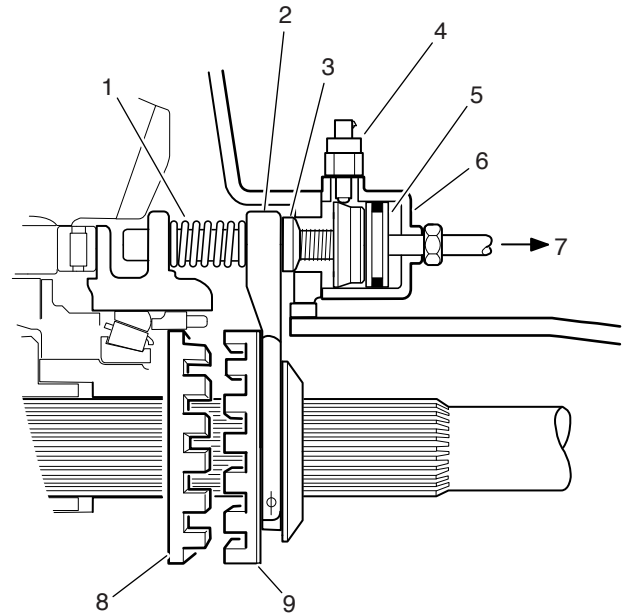

**Differential Lock Disengaged**

- 1 — Spring is decompressed
- 2 — Shift fork
- 3 — Push rod
- 4 — Selector switch
- 5 — Piston
- 6 — Shift cylinder
- 7 — Air pressure applied disengages clutches
- 8 — Fixed clutch splined to differential case
- 9 — Sliding clutch splined to axle shaft

Parts Identification

Power Divider - Forward

Parts Exploded View

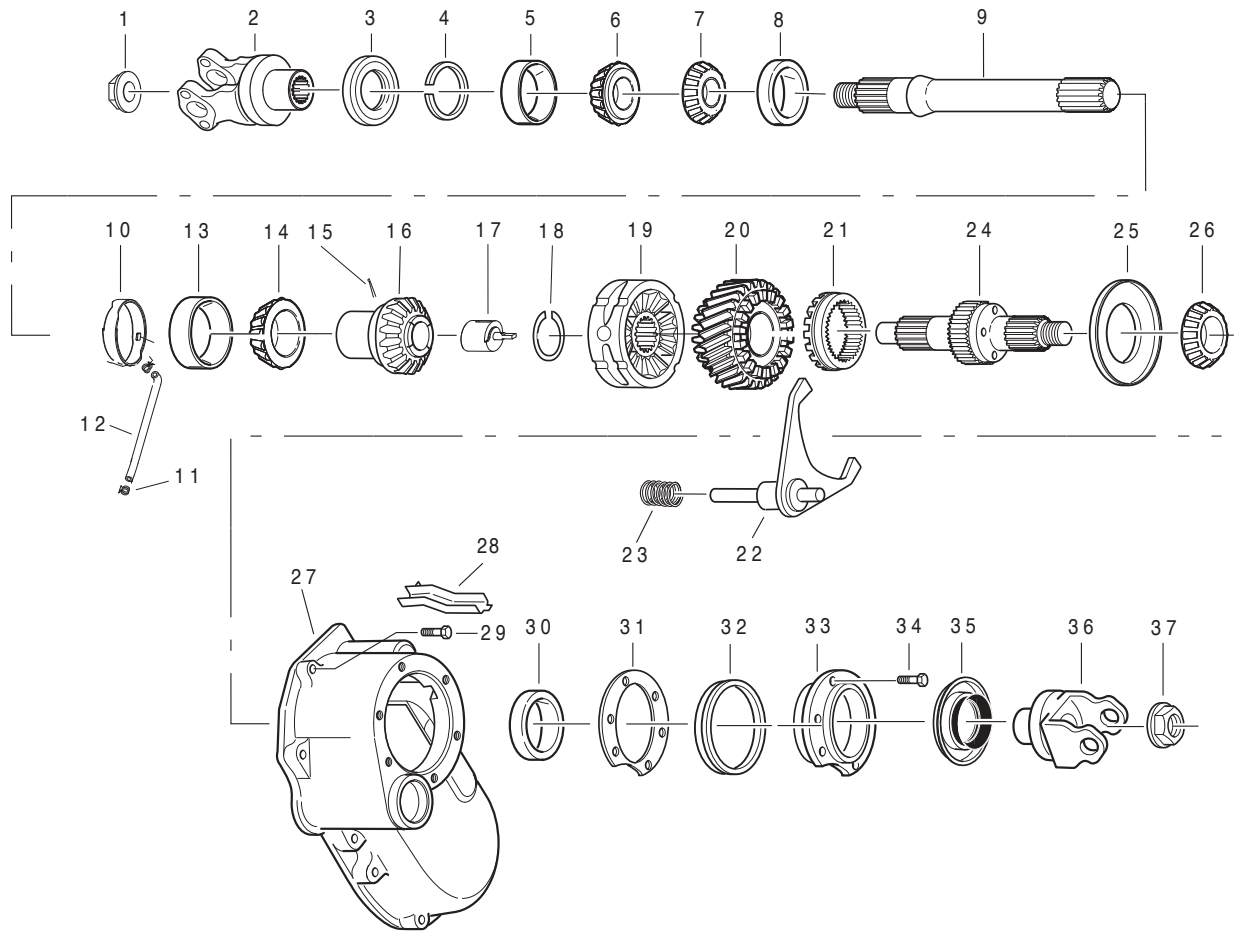

- |                                    |                                    |                          |
|------------------------------------|------------------------------------|--------------------------|
| 1 — Output shaft nut               | 14 — Output side gear bearing cone | 27 — Power divider cover |
| 2 — Output yoke                    | 15 — Pump locking pin              | 28 — Lube trough         |
| 3 — Output seal                    | 16 — Output side gear              | 29 — Cap screw           |
| 4 — Output shaft bearing snap ring | 17 — Pump                          | 30 — Input bearing cup   |
| 5 — Outer bearing cup              | 18 — Snapping ring                 | 31 — Input cage shim     |
| 6 — Outer bearing cone             | 19 — Inter-axle differential       | 32 — Input cage V-ring   |
| 7 — Inner bearing cone             | 20 — Helical side gear             | 33 — Input cage          |
| 8 — Inner bearing cup              | 21 — Sliding clutch                | 34 — Cap screw           |
| 9 — Output shaft                   | 22 — Shift fork assembly           | 35 — Oil Seal            |
| 10 — Seal manifold assembly        | 23 — Spring                        | 36 — Input yoke          |
| 11 — Sump screen                   | 24 — Input shaft                   | 37 — Input nut           |
| 12 — Seal manifold feed tube       | 25 — Input shaft oil retainer      |                          |
| 13 — Output side gear bearing cup  | 26 — Input shaft bearing cone      |                          |



Front Drive Axle

Parts Exploded View

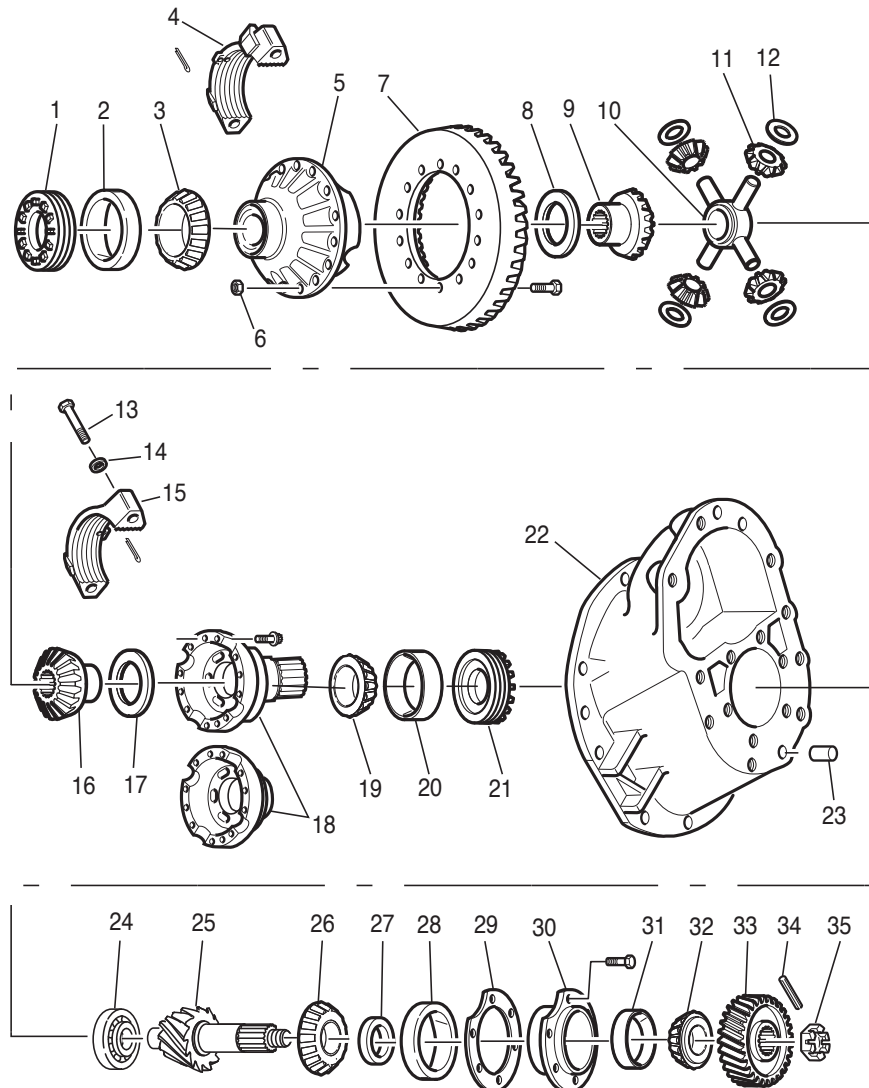

- 1 — Flange half bearing adjuster
- 2 — Flange half bearing cup
- 3 — Flange half bearing cone
- 4 — Flange half carrier cap
- 5 — Flange half differential case
- 6 — Nut
- 7 — Ring gear
- 8 — Side gear thrust washer
- 9 — Side gear
- 10 — Wheel differential spider
- 11 — Side pinion
- 12 — Side pinion thrust washer

- 13 — Carrier cap bolt
- 14 — Lock washer
- 15 — Plain half carrier cap
- 16 — Side gear
- 17 — Side gear thrust washer
- 18 — Plain half differential case
- 19 — Plain half bearing cone
- 20 — Plain half bearing cup
- 21 — Plain half bearing adjuster
- 22 — D-head carrier or front carrier
- 23 — Dowel
- 24 — Pinion pilot bearing

- 25 — Pinion
- 26 — Inner pinion bearing cone
- 27 — Pinion bearing spacer
- 28 — Inner pinion bearing cup
- 29 — Pinion cage shim
- 30 — Pinion cage
- 31 — Outer pinion bearing cup
- 32 — Outer pinion bearing cone
- 33 — Helical gear
- 34 — Pinion roll pin
- 35 — Pinion nut

Wheel Differential Lock Assembly

Parts Exploded View

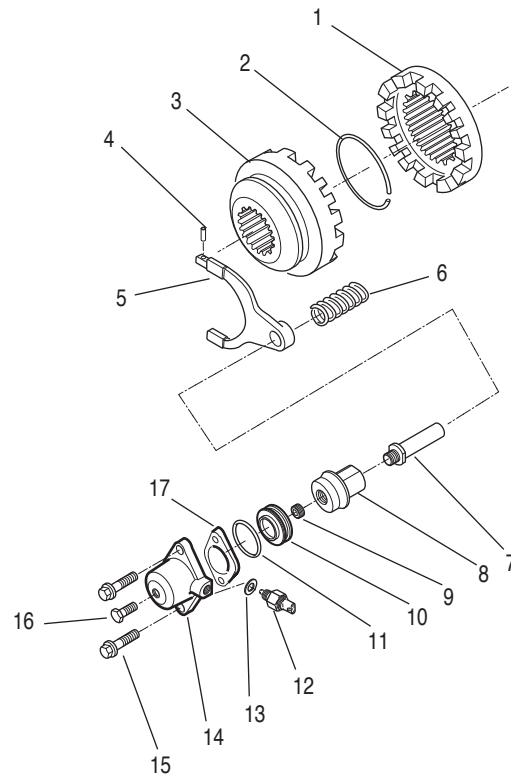

- 1 — Fixed curvic clutch gear
- 2 — Snap ring
- 3 — Curvic clutch gear
- 4 — Spring pin
- 5 — Shift fork
- 6 — Compression spring

- 7 — Push rod
- 8 — Piston driver
- 9 — Set screw
- 10 — Piston
- 11 — O-ring
- 12 — Switch

- 13 — Plastic washer
- 14 — Piston cove
- 15 — Cap screw- flange head
- 16 — Cap screw- manual engagement
- 17 — Gasket

Parts Exploded View

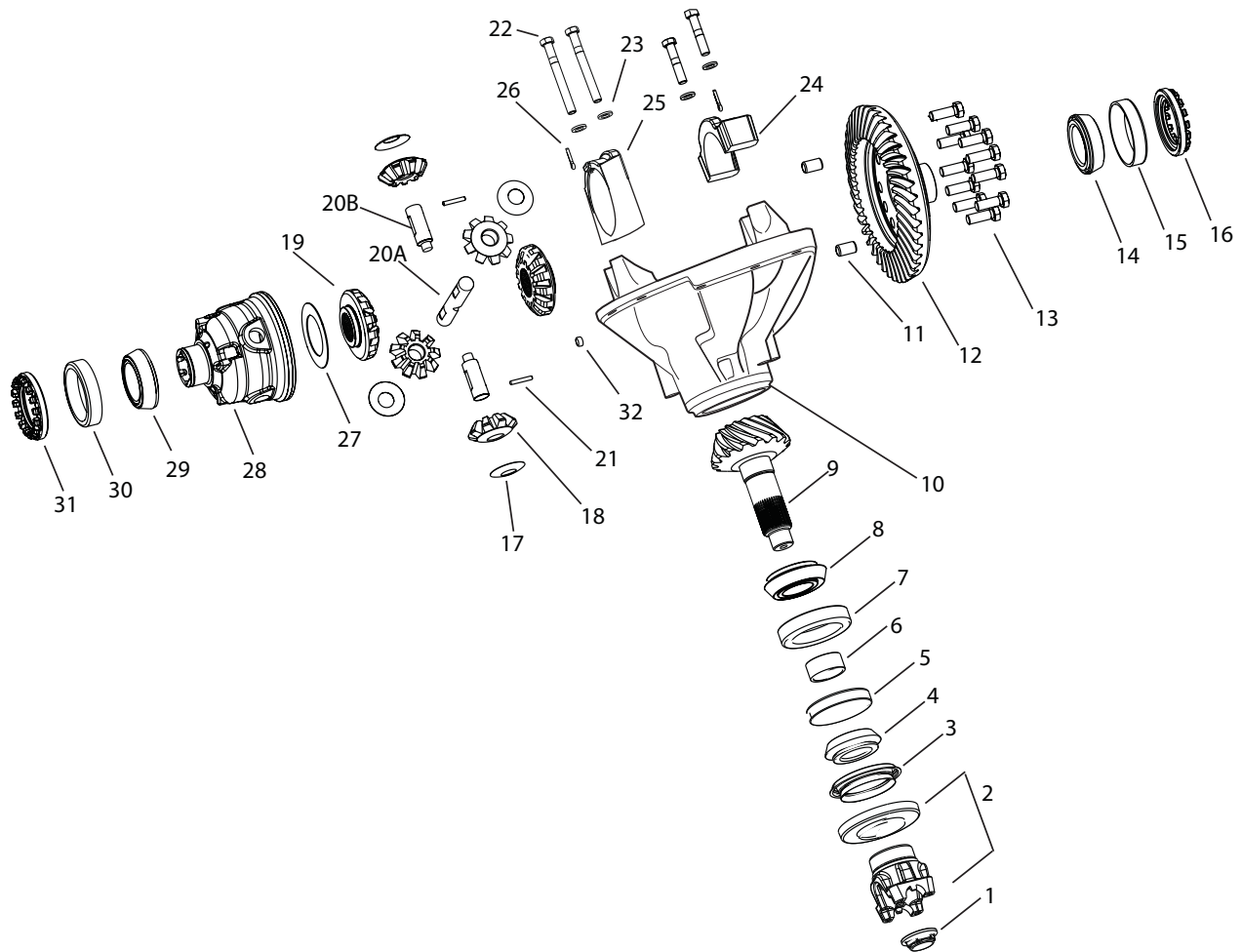

- |                                      |  |   |
|--------------------------------------|--|---|
| <b>1</b> — Pinion nut                | <b>13</b> — Ring gear bolts              | <b>25</b> — Plain half cap              |
| <b>2</b> — End yoke and slinger      | <b>14</b> — Flange half bearing cone     | <b>26</b> — Cotter pin                  |
| <b>3</b> — Oil seal                  | <b>15</b> — Flange half bearing cup      | <b>27</b> — Side gear thrust washer     |
| <b>4</b> — Outer pinion bearing cone | <b>16</b> — Flange half bearing adjuster | <b>28</b> — Plain half diff case        |
| <b>5</b> — Outer pinion bearing cup  | <b>17</b> — Side pinion thrust washer    | <b>29</b> — Plain half bearing cone     |
| <b>6</b> — Pinion spacer             | <b>18</b> — Side pinion                  | <b>30</b> — Plain half bearing cup      |
| <b>7</b> — Inner pinion bearing cup  | <b>19</b> — Side gear                    | <b>31</b> — Plain half bearing adjuster |
| <b>8</b> — Inner pinion bearing cone | <b>20</b> — A, B - Differential shaft    | <b>32</b> — Pipe plug parts             |
| <b>9</b> — Drive pinion              | <b>21</b> — Pin                          |   |
| <b>10</b> — Carrier housing          | <b>22</b> — Capscrew                     |   |
| <b>11</b> — Diff case dowels         | <b>23</b> — Flat washer                  |   |
| <b>12</b> — Ring gear                | <b>24</b> — Flange half cap              |   |

Housing and Output Shaft Assembly

Parts Exploded View

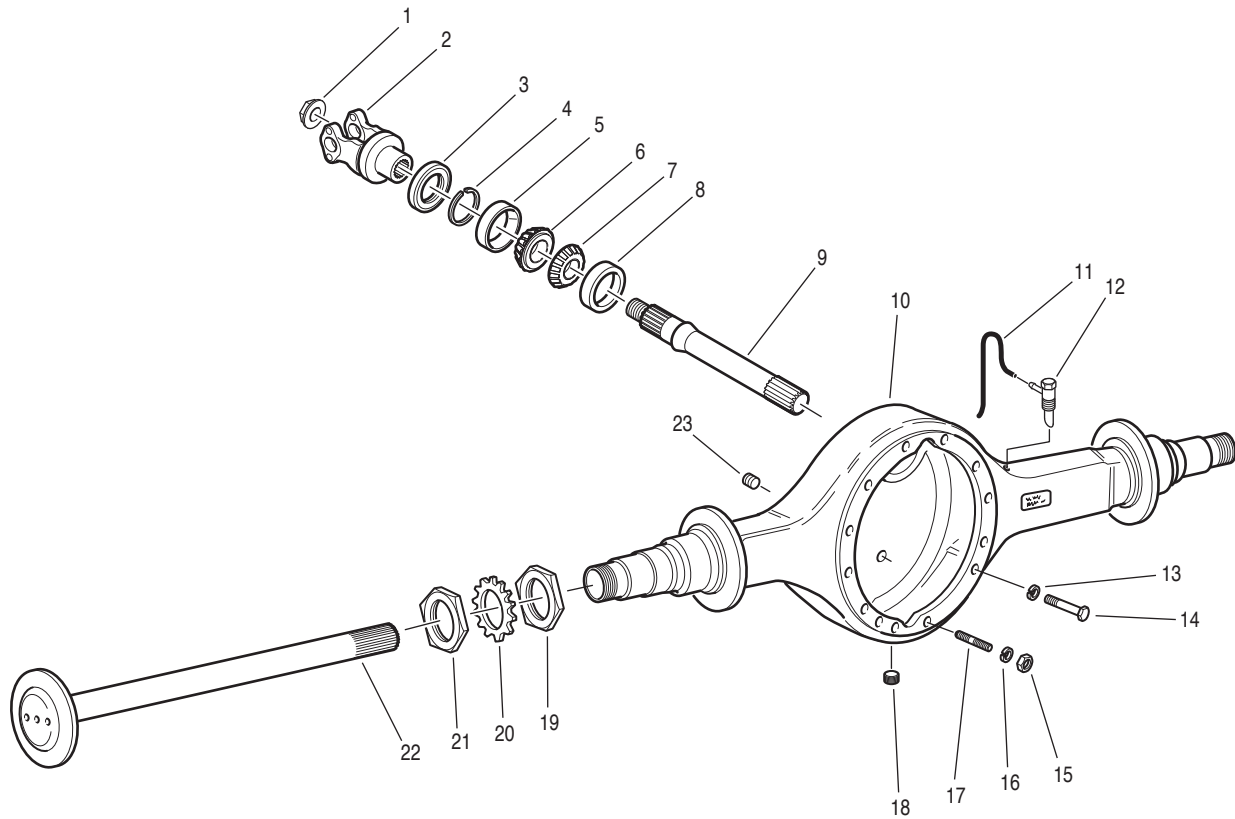

- |                               |                                |                          |
|-------------------------------|--------------------------------|--------------------------|
| <b>1</b> — Output shaft nut   | <b>9</b> — Output shaft        | <b>17</b> — Stud         |
| <b>2</b> — Output yoke        | <b>10</b> — Axle housing       | <b>18</b> — Drain plug   |
| <b>3</b> — Output seal        | <b>11</b> — Breather hose      | <b>19</b> — Spindle nut  |
| <b>4</b> — Snap ring          | <b>12</b> — Breather           | <b>20</b> — Locking ring |
| <b>5</b> — Outer bearing cup  | <b>13</b> — Lock washer        | <b>21</b> — Jam nut      |
| <b>6</b> — Outer bearing cone | <b>14</b> — Carriage cap screw | <b>22</b> — Axle shaft   |
| <b>7</b> — Inner bearing cone | <b>15</b> — Nut                | <b>23</b> — Fill         |
| <b>8</b> — Inner bearing cup  | <b>16</b> — Lock washer        |                          |

## Torque Specifications

### Fastener Torque Specifications

#### Forward Carrier

Location	Size	Lbs. Ft.	N•m
<b>Power Divider</b>			
Input shaft nut	M42 x 1.5	925 ± 30	1254 ± 41
Input cage bolts	M14 x 2	125 ± 20	169 ± 27
Power diver cover	M14 x 2	125 ± 20	169 ± 27
IAD shift cylinder cap	M10 x 1.5	32 ± 5	43 ± 7
Output shaft nut	M39 x 1.5	756 ± 30	1025 ± 41

#### Forward Axle - Carrier and Differential

Carrier cap bolt	M20 x 2.5	390 ± 20	530 ± 27
Pinion nut*	M42 x 1.5	925 ± 30*	1254 ± 41*
Ring gear bolt nut	M16 x 1.5	270 ± 10	380 ± 13
Wheel diff case	M14 x 2	125 ± 20	169 ± 27
Thrust bolt jam nut	M24 x 2	170 ± 20	230 ± 27

#### Rear Axle - Carrier and Differential

Carrier cap bolt	M24 x 3	675 ± 30	915 ± 41
Pinion nut	M42 x 1.5	925 ± 30	1254 ± 41
Ring gear bolt	M20 x 1.5	635 ± 10	860 ± 13

#### Carrier to Housing

Bolt - carrier to housing	M16 x 1.5	310 ± 10	420 ± 13
Nut - carrier to housing	M16 x 1.5	280 ± 10	380 ± 13
Wheel diff lock cap	M10 x 1.5	32 ± 5	43 ± 7
Wheel diff lock switch	M12 x 1.5	25 ± 5	34 ± 7

#### Housing

Forward axle - fill plug	1 x 11.5	50 ± 5	67 ± 7
Rear-rear axle - fill plug	1 x 11.5	50 ± 5	67 ± 7
Forward drain plug	1 x 11.5	50 ± 5	67 ± 7
Breather	.375 - 18	25 ± 5	34 ± 7
Temperature sending plug	.5 - 20	50 ± 5	67 ± 7

**Note:** Fasteners using self-locking thread “patches” may be reused if not damaged, but should be secured by a few drops of Loctite #277 on threaded surface. Reused fasteners should be wiped clean of excess oil, special cleaning not required.

\* Torque nut to 840 lb-ft. (1140 N•m), then continue tightening to align nut slot with nearest hole in pinion shank.

Correct torque values are extremely important to assure long Dana life and dependable performance. Under-tightening of parts is just as harmful as over-tightening.

Exact compliance with recommended torque values will assure the best results.

For spec'ing or service assistance, call 1-877-777-5360 or visit our website at [www.dana.com/cv](http://www.dana.com/cv)

**Dana Commercial Vehicle Products Group**

3939 Technology Drive  
Maumee, Ohio, USA 43537

[www.dana.com/cv](http://www.dana.com/cv)



**SPICER®**

*Drivetrain Products*

**Application Policy**

Capacity ratings, features, and specifications vary depending upon the model and type of service. Application approvals must be obtained from Dana; contact your representative for application approval. We reserve the right to change or modify our product specifications, configurations or dimensions at any time without notice.