

DOUBLE CARDAN CONSTANT VELOCITY JOINT ASSEMBLIES

SPICER[®]



J321 CV
DECEMBER, 2001

Supersedes J321-CV
dated November, 2000

S P I C E R

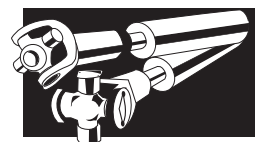

DRIVESHAFT

CONTENTS

	Page
How to Use This Catalog	2
Driveshaft Applications	
Chevrolet - GMC	3-4
Dodge - Plymouth	4-8
Ford	9-15
Isuzu	15
Jeep	16-20
Pontiac	20
Spicer Head Assemblies	21
Socket Yoke Assembly Dimensional Data	22
How to Service Socket Yoke Assemblies	23
Component Drawings	
Welded Assemblies	24-27
Unwelded Assemblies	30-31
Bills of Material	
Welded Assemblies	28-29
Unwelded Assemblies	30-31
Balancing Specifications	32

HOW TO USE THIS CATALOG

To determine replacement driveshaft by Application you may need to know:

1. Make, model and year of vehicle
2. Manual or Automatic transmission, with or without overdrive
3. 3, 4 or 5 speed transmission
4. Engine size and type (diesel or gasoline-4, 6 or 8 cyl)
5. Axle Ratio
6. Series of driveshaft
7. Wheel base of vehicle
8. Location of Driveshaft (front or rear)

To locate applications in this catalog:

- ① Locate proper make of vehicle
- ② Locate proper year of vehicle
- ③ Locate proper model of vehicle
- ④ Match application in catalog with application data gathered concerning vehicle
- ⑤ Determine if it is a front shaft (TC to FA) or a rear shaft (TC to RA)
- ⑥ Locate part number of Spicer Welded Assembly
- ⑦ A finished assembly can be built by using the part number for a Spicer Unwelded Assembly (if shown)
- ⑧ Tube length for Unwelded Assemblies

YEAR/MAKE/MODEL DESCRIPTION	LOCATION	SPICER WELDED ASSEMBLY NUMBER	OEM NUMBER	CENTERLINE TO CENTERLINE OF CROSS (Collapsed Lengths)	SPICER UNWELDED ASSEMBLY	
					PART NUMBER	TUBE LENGTH REQUIRED
CHEVROLET — GMC						
1980 BLAZER, JIMMY						
K10, K15, K20, K25						
1310 Series, Part Time 205 T.C., Manual and Turbo Hydramatic 350 Trans, w/30T Involute Spline	TC to FA	912170-1207	Not Available	23.938	913971-2600	12.219
K20, K25						
1310 Series, Part Time 205 T.C., Turbo 'Hydramatic 400 Trans. w/30T Involute Spline	TC to FA	912170-1511	Not Available	27.156	913971-2600	15.344

OR

If all of the above has been accomplished and the customer only needs a component replaced, refer to the Bill of Material Table starting on page 28 of this catalog.



CAUTION! The items in this catalog are listed for use only in those applications for which they were originally designed and approved. Any other use could result in property damage or serious personal injury. Do not use the items in this catalog except as replacement parts in the "factory stock" vehicles for which they were originally designed.

SPICER DOUBLE CARDAN DRIVESHAFT APPLICATIONS

YEAR/MAKE/MODEL DESCRIPTION	LOCATION	SPICER WELDED ASSEMBLY NUMBER	OEM NUMBER	CENTERLINE TO CENTERLINE OF CROSS (Collapsed Lengths)	SPICER UNWELDED ASSEMBLY		
					PART NUMBER	TUBE LENGTH REQUIRED	
1981-90 BLAZER, JIMMY							
K10, K15, K20, K25 1310 Series, Part Time 208 T.C., Manual and Turbo Hydramatic 350 Trans. w/30T Involute Spline	TC to FA	912170-1803	Not Available	29.906	913971-2600	18.094	
K20, K25 1310 Series, Part Time 208 T.C., Turbo 'Hydramatic 400 Trans. w/30T Involute Spline	TC to FA	912170-1803	Not Available	29.906	913971-2600	18.094	
K30, K35 1310 Series, Part Time 205 T.C., Manual 4 'Speed Trans. w/30T Involute Spline	TC to FA	912170-1107	Not Available	23.031	913971-2600	11.219	
1310 Series, Part Time 205 T.C., Turbo 'Hydramatic 400 Trans. w/30T Involute Spline	TC to FA	912170-1415	Not Available	26.281	913971-2600	14.469	
1980 BLAZER, JIMMY							
K10, K15, K20, K25 1310 Series, Part Time 205 T.C., Manual and Turbo Hydramatic 350 Trans. w/30T Involute Spline	TC to FA	912170-1207	Not Available	23.938	913971-2600	12.219	
K20, K25 1310 Series, Part Time 205 T.C., Turbo 'Hydramatic 400 Trans. w/30T Involute Spline	TC to FA	912170-1511	Not Available	27.156	913971-2600	15.344	
K30, K35 1310 Series, Part Time 205 Transfer Case, Man. Trans. w/ 30 Involute Spline	TC to FA	912170-1107	Not Available	23.031	913971-2600	11.219	
1310 Series, Part Time 205 Transfer Case, Turbo Hydramatic 400 Trans. w/30 Involute Spline	TC to FA	912170-1415	Not Available	26.281	913971-2600	14.469	
1978-79 BLAZER, JIMMY							
K10, K15, K20, K25 1310 Series, Full Time 203 Transfer Case, Turbo Hydramatic 350 Trans. w/30 Involute Spline	TC to FA	912170-1511	Not Available	27.156	913971-2600	15.344	
K20, K25 1310 Series, Full Time 203 Transfer Case, Turbo Hydramatic 350 Trans. w/30 Involute Spline	TC to FA	912170-1803	Not Available	29.906	913971-2600	18.094	
1977-79 BLAZER, JIMMY							
K10, K15, K20, K25 1310 Series, Part Time 205 Transfer Case, Man. Trans. w/30 Involute Spline	TC to FA	912170-1207	Not Available	23.938	913971-2600	12.219	
K30, K35 1310 Series, Part Time 205 Transfer Case with Manual Transmission	TC to FA	903862-1111	370050	23.156	909365-2600	11.344	
1310 Series, Full Time 203 Transfer Case with Turbo Hydramatic 400 Trans.	TC to FA	903862-1706	375205	29.000	909365-2600	17.188	
1977 BLAZER, JIMMY							
K10, K15, K20, K25 1310 Series, Part Time 205 Transfer Case with Manual Transmission	TC to FA	903862-1226	326487	24.625	909365-2600	12.813	

TC to FA — Transfer Case to Front Axle

YEAR/MAKE/MODEL DESCRIPTION	LOCATION	SPICER WELDED ASSEMBLY NUMBER	OEM NUMBER	CENTERLINE TO CENTERLINE OF CROSS (Collapsed Lengths)	SPICER UNWELDED ASSEMBLY	
					PART NUMBER	TUBE LENGTH REQUIRED
CHEVROLET - GMC (Continued)						
1977 BLAZER, JIMMY (Continued)						
1310 Series, Full Time 203 Transfer Case, Turbo Hydramatic 350 Trans. w/30 Involute Spline	TC to FA	912170-1511	Not Available	27.156	913971-2600	15.344
1973-76 BLAZER, JIMMY						
K10, K15, K20, K25 1310 Series with Manual Trans.	TC to FA	903862-1226	326487	24.625	909365-2600	12.938
1310 Series with Automatic Trans.	TC to FA	903862-1602	326479	27.875	909365-2600	16.063
1969-72 BLAZER, JIMMY, K10, K20						
1310 Series	TC to FA	903862-1409		26.094	909365-2600	14.281
1966-69 BLAZER, K10, K20						
1310 Series	TC to FA	903406-1109	3945080	23.250	909363-2600	10.094
DODGE - PLYMOUTH						
1997-98 DAKOTA						
All engines, Man trans	TC to FA	919993-1114	52099203	23.890	Not Available	
All engines, Auto trans	TC to FA	919993-1324	52099204	26.200	Not Available	
1996 DAKOTA						
1310 Series, NV231 trans case, A630 & Aisinseiki transmission	TC to FA	915371-1221	53005551	25.100	Not Available	
1994-95 DAKOTA						
1310 Series, NV231 trans case, 42RE & 46RE auto trans.	TC to FA	915371-1418	52099321	27.000	Not Available	
1310 Series, NV231 trans case, A630 & Aisinseiki man. trans.	TC to FA	915371-1221	53005551	25.100	Not Available	
1310 Series, NV231 trans case, A500 & A518 auto trans	TC to FA	915371-1831	53005548	31.406	Not Available	
1990-93 DAKOTA						
1310 Series, A500 A/T	TC to FA	915371-1221	4384515	25.094	Not Available	
1310 Series, Manual Trans.	TC to FA	915371-1831	4384618	31.406	Not Available	
1987-88 DAKOTA						
1310 Series, A500 A/T	TC to FA	915371-1221	4384515	25.094	Not Available	
1987-88 DAKOTA						
1310 Series, Manual Trans.	TC to FA	915371-1831	4384618	31.406	Not Available	
1975-80 AW1 (DODGE RAMCHARGER AND PLYMOUTH TRAIL DUSTER)						
1310 Series w/ Involute Spline	TC to FA	918586-1514		27.250	916870-2600	15.438
1975 W1, W2 (CONV. CAB)						
1310 Series, 115", 131" & 149" W.B. w/3500 lb. Spicer 44 Axle	TC to FA	908083-1620	3822615	28.000	909365-2600	16.188
1310 Series, 149" Wheel Base w/4500 lb. Spicer 60 Axle	TC to FA	908083-1502	3822616	26.438	909365-2600	14.625
W3 CONV. CAB						
1310 Series, 135" Wheel Base	TC to FA	908083-1502	3822616	26.438	909365-2600	14.375
1999 1500 CONV. CAB						
1330 series, 118" & 134" W.B. 5.2L & 5.9L Eng 46 RE Auto Trans Model 44 Front axle NV 231 HD Trans Case	TC to FA	921716-1515	52105860AA			
1330 series, 118" & 134" WB 5.2L Eng A630 Man Trans Model 44 Front axle NV 231HD Trans Case	TC to FA	921716-1416	52105871AA			

TC to RA — Transfer Case to Rear Axle

YEAR/MAKE/MODEL DESCRIPTION	LOCATION	SPICER WELDED ASSEMBLY NUMBER	OEM NUMBER	CENTERLINE TO CENTERLINE OF CROSS (Collapsed Lengths)	SPICER UNWELDED ASSEMBLY	
					PART NUMBER	TUBE LENGTH REQUIRED
DODGE - PLYMOUTH (Continued)						
1999 2500 CONV. CAB						
1330 series, 134" WB Only 5.2L & 5.9L Eng 46 RE Auto Trans Model 44 Front axle NV 241 Trans Case	TC to FA	921716-1515	52105860AA			
1330 series, 134" WB Only 8.0L Eng 47 RE Auto Trans Model 60 Front axle NV 241 Trans Case	TC to FA	921716-1515	52105860AA			
1330 series, 134" WB Only 5.9 Turbo Diesel Eng 47 RE Auto Trans Model 60 Front axle NV 241 Trans Case	TC to FA	921716-1515	52105860AA			
1330 series, 134" WB Only 5.2L & 5.9L Eng NV4500 Man Trans Model 60 Front axle NV 241 Trans Case	TC to FA	921716-1402	52105840AA			
1330 series, 134" WB Only 5.9L Eng NV4500 Man Trans Model 60 Front axle NV 241HD Trans Case	TC to FA	921716-1402	52105840AA			
1330 series, 134" WB Only 5.2L & 5.9L Eng NV4500 Man Trans Model 44 Front axle NV 241 Trans Case	TC to FA	921716-1416	52105871AA			
1330 series, 134" WB Only 5.2L & 5.9L Eng 46RE Auto Trans Model 60 Front axle NV 241 Trans Case	TC to FA	921716-1416	52105871AA			
1330 series, 134" WB Only 8.0L & 5.9L Turbo Diesel Eng A636 Man Trans Model 60 Front axle NV 241 Trans Case	TC to FA	921716-1416	52105871AA			
1330 series, 134" WB Only 5.9L Eng 46RE Auto Trans Model 60 Front axle NV 241HD Trans Case	TC to FA	921716-1416	52105871AA			
1330 series, 134" WB Only 5.9L Turbo Diesel Eng NV5600 Man Trans Model 60 Front axle NV 241 Trans Case	TC to FA	921716-1924	52105866AA			
1330 series, 134" WB Only 8.0L Eng. A636 Man Trans Model 60 Front axle NV 241HD Trans Case	TC to FA	921716-1601	52105862AA			
1330 series, 134" WB Only 8.0L Eng. 47RE Auto Trans Model 60 Front axle NV 241HD Trans Case	TC to FA	921716-1601	52105862AA			
1330 series, 134" WB Only 5.9L Turbo Diesel 47RE Auto Trans Model 60 Front axle NV 241HD Trans Case	TC to FA	921716-1601	52105862AA			
1330 series, 134" WB Only 8.0L Eng. A636 Man Trans Model 60 Front axle NV 241HD Trans Case	TC to FA	921716-1416	52105871AA			
1330 series, 134" WB Only 5.9L Turbo Diesel A636 Man Trans Model 60 Front axle NV 241HD Trans Case	TC to FA	921716-1416	52105871AA			
1330 series, 134" WB Only 5.9L Turbo Diesel NV5600 Man Trans Model 60 Front axle NV 241HD Trans Case	TC to FA	921716-1924	52105866AA			
1999 2500 CLUB CAB						
1330 series, 138" WB Only 5.9L Eng 46RE Auto Trans Model 60 Front axle NV 241HD Trans Case	TC to FA	921716-1416	52105871AA			
1330 series, 154" WB Only 5.9L Eng NV4500 Man Trans Model 60 Front axle NV 241HD Trans Case	TC to FA	921716-1402	52105840AA			

TC to FA — Transfer Case to Front Axle
TC to RA — Transfer Case to Rear Axle

YEAR/MAKE/MODEL DESCRIPTION	LOCATION	SPICER WELDED ASSEMBLY NUMBER	OEM NUMBER	CENTERLINE TO CENTERLINE OF CROSS (Collapsed Lengths)	SPICER UNWELDED ASSEMBLY	
					PART NUMBER	TUBE LENGTH REQUIRED
DODGE - PLYMOUTH (Continued)						
1999 2500 CLUB CAB						
1330 series, 154" WB Only 5.9L Turbo diesel NV5600 Man Trans Model 60 Front axle NV 241HD Trans Case	TC to FA	921716-1924	52105866AA			
1330 series, 154" WB Only 8.0L & 5.9L Turbo diesel A636 Man Trans Model 60 Front axle NV 241HD Trans Case	TC to FA	921716-1416	52105871AA			
1330 series, 154" WB Only 8.0L & 5.9L Turbo diesel 47RE Auto Trans Model 60 Front axle NV 241HD Trans Case	TC to FA	921716-1601	52105862AA			
1999 3500 CONV. CAB						
1330 series, 138" & 162" WB 5.9L Eng NV4500 Man Trans Model 60 Front axle NV 241HD Trans Case	TC to FA	921716-1402	52105840AA			
1330 series, 138" & 162" WB 5.9L Eng 46RE Auto Trans Model 60 Front axle NV 241HD Trans Case	TC to FA	921716-1416	52105871AA			
1330 series, 138" & 162" WB 8.0L & 5.9L Turbo diesel 47RE Auto Trans Model 60 Front axle NV 241HD Trans Case	TC to FA	921716-1601	52105862AA			
1330 series, 138" & 162" WB 5.9L Turbo diesel NV5600 Man Trans Model 60 Front axle NV 241HD Trans Case	TC to FA	921716-1924	52105866AA			
1330 series, 138" & 162" WB 5.9L Turbo diesel A636 Man Trans Model 60 Front axle NV 241HD Trans Case	TC to FA	921716-1416	52105862AA			
1330 series, 134" WB Only 8.0L Eng. 47RE Auto Trans Model 60 Front axle NV 241HD Trans Case	TC to FA	921716-1601	52105862AA			
1330 series, 134" WB Only 5.9L Turbo Diesel 47RE Auto Trans Model 60 Front axle NV 241HD Trans Case	TC to FA	921716-1601	52105862AA			
1999 3500 CLUB CAB						
1330 series, 138" WB Only 5.9L Eng 46RE Auto Trans Model 60 Front axle NV 241HD Trans Case	TC to FA	921716-1416	52105871AA			
1330 series, 154" WB Only 5.9L Eng NV4500 Man Trans Model 60 Front axle NV 241HD Trans Case	TC to FA	921716-1402	52105840AA			
1330 series, 154" WB Only 5.9L Turbo diesel NV5600 Man Trans Model 60 Front axle NV 241HD Trans Case	TC to FA	921716-1924	52105866AA			
1330 series, 154" WB Only 8.0L & 5.9L Turbo diesel A636 Man Trans Model 60 Front axle NV 241HD Trans Case	TC to FA	921716-1416	52105871AA			
1330 series, 154" WB Only 8.0L & 5.9L Turbo diesel 47RE Auto Trans Model 60 Front axle NV 241HD Trans Case	TC to FA	921716-1601	52105862AA			
1330 series, 138" WB Only 5.9L Eng NV4500 Man Trans Model 60 Front axle NV 241 Trans Case	TC to FA	921716-1402	52105840AA			
1330 series, 154" WB Only 5.9L Eng NV4500 Man Trans Model 60 Front axle NV 241 Trans Case	TC to FA	921716-1402	52105840AA			
1330 series, 154" WB Only 8.0L & 5.9L Turbo Diesel A636 Man Trans Model 60 Front axle NV 241 Trans Case	TC to FA	921716-1416	52105871AA			

TC to FA — Transfer Case to Front Axle
TC to RA — Transfer Case to Rear Axle

YEAR/MAKE/MODEL DESCRIPTION	LOCATION	SPICER WELDED ASSEMBLY NUMBER	OEM NUMBER	CENTERLINE TO CENTERLINE OF CROSS (Collapsed Lengths)	SPICER UNWELDED ASSEMBLY	
					PART NUMBER	TUBE LENGTH REQUIRED
DODGE - PLYMOUTH (Continued)						
1999 3500 CLUB CAB (Continued)						
1330 series, 154" WB Only 8.0L & 5.9L Turbo Diesel 47RE Auto Trans Model 60 Front axle NV 241 Trans Case	TC to FA	921716-1515	52105860AA			
1330 series, 154" WB Only 5.9L Turbo Diesel NV5600 Man Trans Model 60 Front axle NV 241 Trans Case	TC to FA	921716-1924	52105866AA			
1999-2000 1500 CLUB CAB						
1330 series, 138" & 154" WB 5.2L & 5.9L Eng 46RE Auto Trans Model 44 Front axle NV 231 HD Trans Case	TC to FA	921716-1515	52105860AA			
1330 series, 138" & 154" WB 5.2L Eng A630 Man Trans Model 44 Front axle NV 231HD Trans Case	TC to FA	921716-1416	52105871AA			
1999-2000 2500 CLUB CAB						
1330 series, 138" & 154" WB Only 5.9L Eng 46RE Auto Trans Model 60 Front axle NV 241 Trans Case	TC to FA	921716-1416	52105871AA			
2000 2500 CONV CAB						
1330 series, 134" WB Only 8.0L Eng 47RE Auto Trans Model 60 Front axle NV 241HD Trans Case	TC to FA	921782-1601	52105862AB			
1330 series, 134" WB Only 8.0L Eng A636 Man Trans Model 60 Front axle NV 241HD Trans Case	TC to FA	921782-1416	52105871AB			
1330 series, 134" WB Only 5.9L Turbo Diesel A636 Man Trans Model 60 Front axle NV 241HD Trans Case	TC to FA	921782-1416	52105871AB			
1330 series, 134" WB Only 5.9L Turbo Diesel NV5600 Man Trans Model 60 Front axle NV 241HD Trans Case	TC to FA	921782-1924	52105866AB			
1330 series, 134" WB Only 5.9L Turbo Diesel 47RE Auto Trans Model 60 Front axle NV 241HD Trans Case	TC to FA	921782-1601	52105862AB			
1330 series, 134" WB Only 5.9L Eng 46RE Auto Trans Model 60 Front axle NV 241HD Trans Case	TC to FA	921782-1416	52105871AB			
2000 2500 CLUB CAB						
1330 series, 138" & 154" WB Only 5.9L Eng. NV4500 Man Trans Model 60 Front axle NV 241HD Trans Case	TC to FA	921782-1402	52105840AB			
1330 series, 138" & 154" WB Only 5.9L Eng. 46RE Auto Trans Model 60 Front axle NV 241HD Trans Case	TC to FA	921782-1416	52105871AB			
1330 series, 138" & 154" WB Only 5.9L Turbo Diesel 47RE Auto Trans Model 60 Front axle NV 241HD Trans Case	TC to FA	921782-1601	52105862AB			
1330 series, 154" WB Only 5.9L Turbo Diesel A636 Man Trans Model 60 Front axle NV 241HD Trans Case	TC to FA	921782-1416	52105871AB			
1330 series, 138" & 154" WB Only 5.9L Turbo Diesel NV5600 Man Trans Model Front axle NV 241HD Trans Case	TC to FA	921782-1924	52105866AB			
1330 series, 138" & 154" WB Only 8.0L Eng A636 Man Trans Model 60 Front axle NV 241HD Trans Case	TC to FA	921782-1416	52105871AB			
1330 series, 138" & 154" WB Only 8.0L Eng 47RE Auto Trans Model 60 Front axle NV 241HD Trans Case	TC to FA	921782-1601	52105862AB			

TC to FA — Transfer Case to Front Axle
TC to RA — Transfer Case to Rear Axle

YEAR/MAKE/MODEL DESCRIPTION	LOCATION	SPICER WELDED ASSEMBLY NUMBER	OEM NUMBER	CENTERLINE TO CENTERLINE OF CROSS (Collapsed Lengths)	SPICER UNWELDED ASSEMBLY	
					PART NUMBER	TUBE LENGTH REQUIRED
DODGE - PLYMOUTH (Continued)						
2000 3500 CONV CAB						
1330 series, 134" WB Only 5.9L Eng NV4500 Man Trans Model 60 Front axle NV 241HD Trans Case	TC to FA	921782-1402	52105840AB			
1330 series, 138" & 162" WB Only 5.9L Eng NV4500 Man Trans Model 60 Front axle NV 241HD Trans Case	TC to FA	921782-1402	52105840AB			
1330 series, 138" & 162" WB Only 5.9L Eng 46RE Auto Trans Model 60 Front axle NV 241HD Trans Case	TC to FA	921782-1416	52105871AB			
1330 series, 138" & 162" WB Only 8.0L & 5.9L Turbo Diesel 47RE Auto Trans Model 60 Front axle NV 241HD Trans Case	TC to FA	921782-1601	52105862AB			
1330 series, 138" & 162" WB Only 5.9L Turbo Diesel A636 Man Trans Model 60 Front axle NV 241HD Trans Case	TC to FA	921782-1416	52105871AB			
1330 series, 138" & 162" WB Only 5.9L Turbo Diesel NV5600 Man. Trans. Model 60 Front axle NV 241HD Trans Case	TC to FA	921782-1924	52105866AB			
1330 series, 138" & 162" WB Only 8.0L Eng. A636 Man Trans Model 60 Front axle NV 241HD Trans Case	TC to FA	921782-1416	52105871AB			
2000 3500 CLUB CAB						
1330 series, 154" WB Only 5.9L Eng NV4500 Man Trans Model 60 Front axle NV 241HD Trans Case	TC to FA	921782-1402	52105840AB			
1330 series, 154" WB Only 8.0L Eng 46RE Auto Trans Model 60 Front axle NV 241HD Trans Case	TC to FA	921782-1416	52105871AB			
1330 series, 154" WB Only 5.9L Turbo Diesel NV5600 Man Trans Model 60 Front axle NV 241HD Trans Case	TC to FA	921782-1924	52105866AB			
1330 series, 154" WB Only 5.9L Turbo Diesel A636 Man Trans Model 60 Front axle NV 241HD Trans Case	TC to FA	921782-1416	52105871AB			
1330 series, 154" WB Only 5.9L Turbo Diesel 47RE Auto Trans Model 60 Front axle NV 241HD Trans Case	TC to FA	921782-1601	52105862AB			
1330 series, 154" WB Only .0L Eng 8A636 Man Trans Model 60 Front axle NV 241HD Trans Case	TC to FA	921782-1416	52105871AB			
1330 series, 154" WB Only 8.0L Eng 47RE Auto Trans Model 60 Front axle NV 241HD Trans Case	TC to FA	921782-1601	52105862AB			
FORD						
1990-94 BRONCO						
1330 Series, E40D Auto Trans., 4.9L (1992-90), 5.0L, 5.8L Eng. w/3.08 & 3.55 Axle Ratios	TC to RA	915841-1008	F0TA-4602-ZA F1TZ-4602-Z	23.350		Not Available
1330 Series, Manual 5-Spd. w/O.D., Mazda R2 & ZF H.D., 5-Spd. w/O.D. Wide Ratio Trans. 4.9L (1992-90) & 5.0L Eng. w/3.08, 3.55 or 4.10 Axle Ratios	TC to RA	915841-1225	E9TA-4602-NB E9TZ-4602-AC	25.880		Not Available

TC to FA — Transfer Case to Front Axle
TC to RA — Transfer Case to Rear Axle

YEAR/MAKE/MODEL DESCRIPTION	LOCATION	SPICER WELDED ASSEMBLY NUMBER	OEM NUMBER	CENTERLINE TO CENTERLINE OF CROSS (Collapsed Lengths)	SPICER UNWELDED ASSEMBLY	
					PART NUMBER	TUBE LENGTH REQUIRED
FORD (Continued)						
1990-93 BRONCO						
1330 Series, Automatic Overdrive Trans. (AOD), 5.0L Eng., 3.55 or 4.10 Axle Ratios	TC to RA	915841-1506	E9TA-4602-PB E9TZ-4602-AD	28.290	Not Available	
1330 Series, C6 Auto Trans. or Borg Warner T-18 Manual 4-Spd. Wide Ratio, 4.9L(92-90) & 5.0L Eng. w/3.08 or 3.55 Axle Ratio	TC to RA	915841-1606	E9TA-4602-MB E9TZ-4602-AB	29.290	Not Available	
1987-89 BRONCO						
1330 Series, C6 Automatic Trans., 4.9L & 5.8L E.F.I. Eng. w/3.08 & 3.55 Axle Ratios	TC to RA	912637-1617	E7TA-4602-SA E7TZ-4602-B	29.630	Not Available	
1330 Series All w/5.0L E.F.I. Eng. w/3.08 & 3.55 Axle Ratios	TC to RA	912637-1517	E7TZ-4602-A E7TA-4602-UA	28.630	Not Available	
1330 Series, Manual 5-Spd. w/O.D. mazda RZ and ZF H.D. 5-sd. w/O.D. Wide Ratio Transmissions, 4.9L & 5.0L E.F.I. Eng. w/3.08, 3.55, 4.10 Axle Ratios	TC to RA	912637-1313	E8TA-4602-NA E8TZ-4602-U	26.510	Not Available	
1987 BRONCO						
1330 Series, C6 Automatic and New Process 435 Manual Trans. 5.0L & 5.8L Eng. W/3.50 Axle Ratio	TC to RA	912637-1718	E7TA-4602-TA	30.660	Not Available	
1330 Series, All w/4.9L Eng. and 5.0L Eng. w/Automatic Overdrive Trans.	TC to RA	912637-1617	E7TA-4602-SA E7TZ-4602-B	29.630	Not Available	
1986 BRONCO						
1330 Series, Automatic O.D. Trans., 5.0 E.F.I. Eng. w/3.55 Axle Ratio	TC to RA	912637-1609	E5TZ-4602-M	29.380	Not Available	
1330 Series, C6 Auto. & Man. 4-Spd. Trans. 5.0L E.F.I. & 5.8L Eng. w/3.50 Axle Ratio	TC to RA	912637-1806	E5TZ-4602-K	31.290	Not Available	
1330 Series, All w/4.9L Eng. and 5.0L E.F.I. Eng. with 4.11 Axle Ratio	TC to RA	912637-1705	E5TZ-4602-L	30.260	Not Available	
1985 BRONCO						
1330 Series, Automatic O.D. Trans., 5.0L Eng. w/3.55 Axle Ratio	TC to RA	912637-1609	E5TZ-4602-M	29.380	Not Available	
1330 Series, Manual 4-Spd. Trans., 4.9L Eng. w/3.00 & 3.50 Axle Ratios, All 5.0L & 5.8L Eng. w/3.50 Axle Ratios	TC to RA	912637-1806	E5TZ-4602-K	31.290	Not Available	
1330 Series, All 4.9L Eng. w/3.55 & 3.08 Axle Ratios, also Automatic O.D. Trans., 5.0L Eng. w/4.11 Rear Axle Ratio	TC to RA	912637-1705	E5TZ-4602-L	30.260	Not Available	
1983-84 BRONCO						
1330 Series	TC to RA	910719-1709	E3TZ-4602-AF	30.094	911818-2600	17.281
1980-82 BRONCO						
1330 Series	TC to RA	910719-1723	E0TZ-4602-AP	30.351	911818-2600	17.719
1979 BRONCO						
1330 Series, Part Time Transfer Case, 351 Eng. w/ Manual Trans.	TC to FA	910721-1228	D9TZ-4602-AP	24.344	Not Available	
1330 Series, Part Time Transfer Case, 351 Eng. w/ Manual Trans.	TC to RA	910719-2420	D9TZ-4602-AK	37.281	911818-2600	24.625
1330 Series, Part Time Transfer Case 351 Eng. w/ Automatic Transmission	TC to FA	910729-1531	D9TZ-4602-BS	27.281	Not Available	
1330 Series, Part Time Trans. Case, 351 Eng. w/ Automatic Transmission	TC to RA	910719-2121	D9TZ-4602-AL	34-313	911818-2600	21.656
1330 Series, Full Time Trans. Case, 351 Eng. w/ Automatic Transmission	TC to FA	910721-1820	D9TZ-4602-U	30.094	Not Available	
1330 Series, Full Time Trans. Case, 351 Eng. w/ Automatic Transmission	TC to RA	910719-1521	D9TZ-4602-AM	28.313	911818-2600	15.656

TC to FA — Transfer Case to Front Axle
TC to RA — Transfer Case to Rear Axle

YEAR/MAKE/MODEL DESCRIPTION	LOCATION	SPICER WELDED ASSEMBLY NUMBER	OEM NUMBER	CENTERLINE TO CENTERLINE OF CROSS (Collapsed Lengths)	SPICER UNWELDED ASSEMBLY	
					PART NUMBER	TUBE LENGTH REQUIRED
FORD (Continued)						
1978 BRONCO						
1310 Series, Part Time 205 Trans. Case, 351 & 400 Eng. w/Manual Trans., 3.50 & 4.11 Axle Ratio	TC to FA	906638-1226	D8TZ-4602-R	24.344	909363-2600	11.188
1310 Series, Part Time 205 Trans. Case, 351 & 400 Eng. w/Manual Trans., 3.50 & 4.11 Axle Ratio	TC to RA	910255-2405	D8TZ-4602-H	37.313	909363-2600	24.156
1310 Series, Part Time 205 Trans. Case, 351 Eng. w/AutomaticTrans., 3.00 Axle Ratio	TC to FA	909762-1529	D8TZ-4602-L	27.281	Not Available	
1310 Series, Part Time 205 Trans. Case, 351 Eng. w/AutomaticTrans., 3.00 Axle Ratio	TC to RA	910255-2107	D8TZ-4602-K	34.375	909363-2600	21.219
1310 Series, Full Time 203 Trans. Case, 351 Eng. w/Automatic Trans. & 3.00 Axle Ratio	TC to FA	906638-1818	D8TZ-4602-S	30.094	909363-2600	16.938
1310 Series, Full Time 203 Trans. Case, 351 Eng. w/ Automatic Trans. & 3.00 Axle Ratio	TC to RA	910255-1507	D8TZ-4602-J	29.375	909363-2600	15.219
1310-1330 Series, Part Time 205 Trans. Case, 400 Eng. w/Automatic Trans. and 3.00 Axle Ratio	TC to FA	910539-1531	D8TZ-4602-T	27.281	Not Available	
1310-1330 Series, Full Time 203 Trans. Case, 400 Eng. w/Automatic Trans. and 3.00 Axle Ratio	TC to FA	910424-1820	D8TZ-4602-U	30.094	Not Available	
1974-77 BRONCO						
1310 Series, All Trans. Cases, 302 Eng. w/ Automatic or Manual Trans.	TC to FA	904084-1023	D1TZ-4602-G	22.250	909363-2600	90.94
1310 Series, All Transfer Cases, 302 Eng. w/ Auto. or Manual Transmission	TC to RA	907545-1802	C9TZ-4602-W	31.219	909363-2600	18.063
1971-73 BRONCO						
1310 Series	TC to FA	904084-1023	D1TZ-4602-G	22.250	909363-2600	9.094
1310 Series	TC to RA	907545-1802	C9TZ-4602-W	31.219	909363-2600	18.063
1966-70 BRONCO						
1310 Series, after Serial # 670,000	TC to FA	904084-1125	C9TZ-4602-V	23.313	909363-2600	10.156
1310 Series, after Serial # 670,000	TC to RA	907545-1802	C9TZ-4602-W	31.219	909363-2600	18.063
1310 Series, before Serial #670,000 with Mechanics 2RL Joints	TC to FA	905026-1125	C9TZ-4602-Z	23.313	909363-2600	10.156
1310 Series, before Serial #670,000 with Mechanics 2RL Joints	TC to RA	905027-1802	C9TZ-4602-AA	31.219	909363-2600	18.063
1989-90 BRONCO II						
1210 Series, 4-Spd. Auto., 5-Spd. Man., 2.9L	TC to RA	914778-1013	Not Available	25.850	Not Available	
1210 Series, 4-Spd. Automatic, 2.9L Dbl. Cardan at Tran	TC to RA	914155-1906	Not Available	32.200	919976-3400	19.56
1210 Series, 5-Spd. Manual, 2.9L Dbl. Cardan at Tran	TC to RA	914155-2217	Not Available	35.540	919976-3400	22.91
1988 BRONCO II						
1210 Series, 4-Spd. Automatic, 5-Spd. Manual, 2.9L	TC to RA	914778-1013	Not Available	25.850	Not Available	
1986-87 BRONCO II						
1210 Series, 5-Spd. Manual/O.D., w2.3L, 2.9L, 2.3D Dbl. Cardan at Trans. Case End	TC to RA	914155-1522	Not Available	28.690	919976-3400	16.06
1985-87 BRONCO II						
1210 Series, 4-Spd. Auto., 2.8L, 2.9L	TC to RA	914778-1013	Not Available	25.850	Not Available	

TC to FA — Transfer Case to Front Axle
TC to RA — Transfer Case to Rear Axle

YEAR/MAKE/MODEL DESCRIPTION	LOCATION	SPICER WELDED ASSEMBLY NUMBER	OEM NUMBER	CENTERLINE TO CENTERLINE OF CROSS (Collapsed Lengths)	SPICER UNWELDED ASSEMBLY	
					PART NUMBER	TUBE LENGTH REQUIRED
FORD (Continued)						
1985 BRONCO II						
1210 Series	TC to RA	913682-1001	E5TZ-4602-N	25.470	Not Available	
1997-98 EXPEDITION						
4R70W Trans 4.6L 8.8" Axle	TC to RA	918813-3401	F75A-4602-RA	39.844	Not Available	
E40D Trans. 5.4L 9.75" Axle	TC to RA	919526-2803	F75A-4602-TB	34.438	Not Available	
1998 EXPLORER						
5.0L All trans., All axle ratios	TC to FA	032DS85002-2228	F77A-4A376-CB	N.A	Not Available	
4X4 All except 2 Door, All Trans., All Engines, All axle ratios	TC to FA	032DS85002-2331	F77A-4A376-BB	N.A	Not Available	
1997 EXPLORER						
4X4 All except 2 Door, All Trans., All Engine, All Axle Ratio All axle ratios	TC to FA	032DS85002-2329	F77A-4A376-BA	N.A	Not Available	
1997-96 1/2 EXPLORER						
4X4 2 Door and 4 Door, All Trans., All Engine, All Axle Ratio W/CIRC FLANGE AT TC	TC to FA	920309-1402	F65A-4A376-BA	27.800	Not Available	
1995-96 EXPLORER						
4X4 All except 2 Door, All Trans., All Engine, All Axle Ratio	TC to FA	919221-1413	F57A-4A376-AB	28.200	Not Available	
1995-96 EXPLORER						
4X4 All 2 Door, All Trans., All Engine, All Axle Ratio	TC to RA	919292-2000	F57A-4602-DC	32.900	Not Available	
1991-94 EXPLORER						
4X4 2 Door and 4 Door, All Trans., All Engine, All Axle Ratio	TC to FA	918490-1717	F07A-4A376-AA F07Z-4A376-A F37A-4A376-BB	29.440	Not Available	
1974-76 F100						
1310 Series, 360 Eng. w/Automatic C6 Trans. and 116" Wheel Base	TC to FA	904084-1908	D4TZ-4602-M	30.781	909363-2600	17.625
1998 F150						
4X4 4.2L, 4.6L M50D, 4R70W Trans 120" WB	TC to RA	920260-3523	F75A-4602-GA	41.531	Not Available	
5.0L E40D Trans 120" WB	TC to RA	920267-2921	F75A-4602-SC	36.000	Not Available	
1997 F150						
4X4 4.2L, 4.6L M50D, 4R70W Trans 120" WB	TC to RA	920260-3523	F65A-4602-CB	41.531	Not Available	
5.0L E40D Trans 120" WB 120" WB	TC to RA	920267-2921	F75A-4602-SB	36.000	Not Available	
1979 F150						
1330 Series Part Time Transfer Case w/ Manual Trans. & 16.8" Wheel Base	TC to RA	910720-3806	D9TZ-4602-AN	51.000	Not Available	
1330 Series w/Automatic Trans. & 116.8" & 133" Wheel Base	TC to FA	910721-1820	D9TZ-4602-U	30.094	Not Available	
1330 Series, Full Time Trans. Case, 351 Eng. w/Auto. Trans. & 155" W.B.	TC to FA	910721-1912	D9TZ-4602-X	30.844	Not Available	
1330 Series, Part Time Transfer Case, 400 Eng. w/Manual Trans. and 155" Wheel Base	TC to FA	910721-1320	D9TZ-4602-V	25.094	Not Available	
1978 F150						
1310-1330 Series, Part Time 205 Transfer Case with 116.8" Wheel Base	TC to RA	910413-3806	D8TZ-4602-D	50.938	Not Available	
1310 Series, Full Time 203 Transfer Case with 166.8" and 113" Wheel Base	TC to FA	906638-1818	D8TZ-4602-S	30.094	909363-2600	16.938
1310-1330 Series, Full Time 203 Trans. Case w/Automatic Trans., 116.8" & 133" Wheel Base and 3.00 Axle Ratio	TC to FA	910721-1820	D9TZ-4602-U	30.094	Not Available	

TC to FA — Transfer Case to Front Axle
TC to RA — Transfer Case to Rear Axle

YEAR/MAKE/MODEL DESCRIPTION	LOCATION	SPICER WELDED ASSEMBLY NUMBER	OEM NUMBER	CENTERLINE TO CENTERLINE OF CROSS (Collapsed Lengths)	SPICER UNWELDED ASSEMBLY	
					PART NUMBER	TUBE LENGTH REQUIRED
FORD (Continued)						
1977 F150						
1310 Series, Part Time Transfer Case, 351, 400 Eng. with C6 Trans. and 116" Wheel Base before Serial # Y80,001	TC to RA	907758-3621	D7TZ-4602-J	50.938	Not Available	
1310-1330 Series, Part Time Transfer Case, 351, 400 Eng. with C6 Trans and 116" Wheel Base after Serial # Y80,001	TC to RA	910413-3806	D8TZ-4602-D	50.938	Not Available	
1310 Series, Full Time Transfer Case w/116" & 133" Wheel Base before Serial # Y80,001	TC to FA	904084-1908	D4TZ-4602-M	30.781	909363-2600	17.625
1976 F150						
1310 Series, Manual Trans., with 116.8" Wheel Base	TC to RA	907758-3703	D6TZ-4602-E	51.375	Not Available	
1999-2000 F250HD						
1350 Series, 5.4L engine w/ E4OD Auto Trans, and 137" WB	TC to RA	921007-3702	F81Z-4602-DG	50.875	Not Available	
1350 Series, 5.4L engine w/ M5HD Man. Trans, and 137" WB	TC to RA	921007-4016	F81Z-4602-DH	54.290	Not Available	
1350-1410 Series, 6.8L engine w/ E4OD Auto Trans, and 137" WB	TC to RA	920575-3708	F81Z-4602-CC	50.790	Not Available	
1350-1410 Series, 6.8L engine w/ M5HD Man. Trans, and 137" WB	TC to RA	920575-4024	F81Z-4602-DC	54.290	Not Available	
1350-1410 Series, 7.3L engine w/ E4OD Auto Trans, and 137" WB	TC to RA	920575-3413	F81Z-4602-CN	49.57	Not Available	
1350-1410 Series, 7.3L engine w/ M5HD Man. Trans, and 137" WB	TC to RA	920575-3616	F81Z-4602-DA	51.66	Not Available	
1350 Series, 5.4L engine w/ E4OD Auto Trans, and 141.8" WB	TC to RA	921007-4127	F81Z-4602-DK	57.25	Not Available	
1350-1410 Series, 5.4L engine w/ M5HD Man. Trans, and 141.8" WB	TC to RA	920575-4512	F81Z-4602-DL	60.54	Not Available	
1350-1410 Series, 6.8L engine w/ E4OD Auto Trans, and 141.8" WB	TC to RA	920575-4203	F81Z-4602-DM	57.25	Not Available	
1350-1410 Series, 6.8L engine w/ M5HD Man. Trans, and 141.8" WB	TC to RA	920575-4520	F81Z-4602-DN	60.79	Not Available	
1350-1410 Series, 7.3L engine w/ E4OD Auto Trans, and 141.8" WB	TC to RA	920575-3909	F81Z-4602-DQ	54.45	Not Available	
1350-1410 Series, 7.3L engine w/ M5HD Man. Trans, and 141.8" WB	TC to RA	920575-3909	F81Z-4602-DQ	54.45	Not Available	
1979 F250						
1330 Series, Part Time Transfer Case, 300 Eng. w/Manual Trans. & 133" Wheel Base	TC to FA	910721-1320	D9TZ-4602-V	25.094	Not Available	
1978 F250						
1310-1330 Series, Part Time 205 Transfer Case w/Manual Trans. and 133" Wheel Base	TC to FA	910424-1320	D7TZ-4602-AG	25.094	Not Available	
1310-1330 Series, Part Time 205 Transfer Case w/Automatic Trans. and 133" Wheel Base	TC to FA	910424-1618	D7TZ-4602-AJ	28.031	Not Available	
1310-1330 Series, Full Time 203 Transfer Case w/Automatic Trans. and 133" Wheel Base	TC to FA	910424-1911	D7TZ-4602-AH	30.813	Not Available	
F250 WITH SNOW PLOW OPTION						
1310-1330 Series, Part Time 205 Transfer Case with Manual Trans. and 133" Wheel Base	TC to FA	910424-1909	D8TZ-4602-AL	23.750	Not Available	

TC to FA — Transfer Case to Front Axle
TC to RA — Transfer Case to Rear Axle

YEAR/MAKE/MODEL DESCRIPTION	LOCATION	SPICER WELDED ASSEMBLY NUMBER	OEM NUMBER	CENTERLINE TO CENTERLINE OF CROSS (Collapsed Lengths)	SPICER UNWELDED ASSEMBLY	
					PART NUMBER	TUBE LENGTH REQUIRED
FORD (Continued)						
1978 F250						
1310-1330 Series, Part Time 205 Transfer Case with Automatic Trans. and 133" Wheel Base	TC to FA	910424-1507	D8TZ-4602-AM	26.688	Not Available	
1310-1330 Series, Full Time 203 Transfer Case with Automatic Trans. and 133" Wheel Base	TC to FA	910424-1801	D8TZ-4602-AN	29.500	Not Available	
1977 F250						
1310-1330 Series, Part Time 205 Transfer Case with Automatic Trans. and 133" Wheel Base	TC to FA	910424-1320	D7TZ-4602-AG	25.094	Not Available	
1310-1330 Series, Part Time 205 Transfer Case, 351, 400 Eng. w/Automatic C6 Trans. and 133" Wheel Base after Serial # 40,001	TC to FA	910424-1618	D7TZ-4602-AJ	28.031	Not Available	
1310-1330 Series, Full Time 203 Transfer Case, 351, 400 Eng. w/Automatic C6 Trans. and 133" Wheel Base after Serial # 40,001	TC to FA	910424-1911	D7TZ-4602-AH	30.813	Not Available	
1977 F250						
1310 Series, Full Time 203 Transfer Case, 351, 400 Eng. w/Automatic Trans.	TC to FA	907758-4304	D4TZ-4602-N	57.406	Not Available	
1310 Series, Full Time 203 Transfer Case, 351, 400 Eng. w/Automatic Trans.	TC to RA	907545-1615	D4TZ-4602-L	29.625	909363-2600	16.469
1974-76 F250						
1310 Series, Full Time 203 Trans. Case w/Auto. Trans. & 133" Wheel Base	TC to FA	907758-4304	D4TZ-4602-N	57.406	Not Available	
1310 Series, Full Time 203 Trans. Case w/ Auto. Trans. and 133" Wheel Base	TC to RA	907545-1615	D4TZ-4602-L	29.625	909363-2600	16.469
1999-2000 F350						
1350 Series, 5.4L engine w/ E4OD Auto Trans, and 137" WB	TC to RA	921007-3702	F81Z-4602-DG	50.875	Not Available	
1350 Series, 5.4L engine w/ M5HD Man. Trans, and 137" WB	TC to RA	921007-4016	F81Z-4602-DH	54.290	Not Available	
1999-2000 F350DRW						
1350 Series, 5.4L engine w/ E4OD Auto Trans, and 137" WB	TC to RA	921007-3702	F81Z-4602-DG	50.875	Not Available	
1350 Series, 5.4L engine w/ M5HD Man. Trans, and 137" WB	TC to RA	921007-4016	F81Z-4602-DH	54.290	Not Available	
1350 Series, 6.8L engine w/ E4OD Auto Trans, and 137" WB	TC to RA	920575-3616	F81Z-4602-DA	50.875	Not Available	
1350 Series, 6.8L engine w/ M5HD Man. Trans, and 137" WB	TC to RA	920575-4000	F81Z-4602-CS	54.290	Not Available	
1350 Series, 7.3L engine w/ E4OD Auto Trans, and 137" WB	TC to RA	920575-3321	F81Z-4602-CA	50.875	Not Available	
1350 Series, 7.3L engine w/ M5HD Man. Trans, and 137" WB	TC to RA	920575-3321	F81Z-4602-CA	54.290	Not Available	
1999-2000 F350						
1350-1410 Series, 6.8L engine w/ E4OD Auto Trans, and 137" WB	TC to RA	920575-3708	F81Z-4602-CC	50.790	Not Available	
1350-1410 Series, 6.8L engine w/ M5HD Man. Trans, and 137" WB	TC to RA	920575-4024	F81Z-4602-DC	54.290	Not Available	
1350-1410 Series, 7.3L engine w/ E4OD Auto Trans, and 137" WB	TC to RA	920575-4000	F81Z-4602-CN	55.16	Not Available	

TC to FA — Transfer Case to Front Axle
TC to RA — Transfer Case to Rear Axle

YEAR/MAKE/MODEL DESCRIPTION	LOCATION	SPICER WELDED ASSEMBLY NUMBER	OEM NUMBER	CENTERLINE TO CENTERLINE OF CROSS (Collapsed Lengths)	SPICER UNWELDED ASSEMBLY	
					PART NUMBER	TUBE LENGTH REQUIRED
FORD (Continued)						
1999-2000 F350						
1350-1410 Series, 7.3L engine w/ M5HD Man. Trans, and 137" WB	TC to RA	920575-3321	F81Z-4602-DA	48.82	Not Available	
1350-1410 Series, 5.4L engine w/ E4OD Auto Trans, and 141.8" WB	TC to RA	921007-4227	F81Z-4602-DK	58.26	Not Available	
1350-1410 Series, 5.4L engine w/ M5HD Man Trans, and 141.8" WB	TC to RA	921007-4512	F81Z-4602-DL	60.79	Not Available	
1350-1410 Series, 6.8L engine w/ E4OD Auto Trans, and 141.8" WB	TC to RA	920575-4203	F81Z-4602-DM	57.25	Not Available	
1350-1410 Series, 6.8L engine w/ M5HD Man Trans, and 141.8" WB	TC to RA	920575-4520	F81Z-4602-DN	60.79	Not Available	
1350-1410 Series, 7.3L engine w/ E4OD Auto Trans, and 141.8" WB	TC to RA	920575-3909	F81Z-4602-DQ	54.45	Not Available	
1350-1410 Series, 7.3L engine w/ M5HD Man Trans, and 141.8" WB	TC to RA	920575-3909	F81Z-4602-DQ	54.45	Not Available	
1989-94 F350						
1330 Series, C6 Auto Trans 5.8L & 7.5L Eng.	TC to FA	913764-2025	E5TA-4A376-DA E5TZ-4A376-B	32.250	Not Available	
1330 Series, ZF H.D. 5-Spd. w/O.D., w/O.D., Wide or Close Ratio, 7.5L & 7.3L Diesel	TC to FA	913764-2109	E9TA-4A376-DA E5TZ-4A376-C E9TZ-4A376-C	32.750	Not Available	
1330 Series, ZF H.D. 5-Spd. w/O.D. Wide Ratio, 5.8L Eng.	TC to FA	913764-2406	E9TA-4A376-EA E9TZ-4A376-D	35.660	Not Available	
1330 Series, E40D Trans, All Engines	TC to FA	913764-2623	E9TZ-4A376-A E9TA-4A376-CA	38.190	Not Available	
1987-88 F350						
1330 Series 133" W.B., All Eng., B.W. T18, C6 Automatic and/or New Process 435 Manual Transmissions SRW	TC to FA	913764-2025	E5TA-4A376-DA E5TZ-4A376-B	32.250	Not Available	
1330 Series 133" W.B. All Eng. Man. 5-Spd. w/O.D. & B.W. T19 Trans. SRW	TC to FA	913764-2109	E5TA-4A376-C E5TZ-4A376-EA	32.750	Not Available	
1330 Series, 136.8" W.B., All Eng., Automatic Trans. DRW	TC to FA	913764-2025	E5TA-4A376-DA	32.188	Not Available	
1330 Series, 136.8" W.B., All Eng., Manual Trans. DRW	TC to FA	913764-2109	E5TA-4A376-EA	32.750	Not Available	
1986 F350						
1330 Series, 133" W.B., 6.9L & 7.5L Eng. w/Manual Trans. and E6 Monobeam Axle SRW	TC to FA	913764-2109	E5TZ-4A376-C	32.750	Not Available	
1330 Series, 133" W.B., All with 5.8L Eng., All Automatic Trans. w/6.9L & 7.5L. Eng. & E6 Monobeam Axle SRW	TC to FA	913764-2025	E5TZ-4A376-B	32.250	Not Available	
1985-86 F350						
1330 Series, 136.8" W.B., All w/Automatic Trans. DRW	TC to FA	913764-2025	E5TZ-4A376-B	32.250	Not Available	
1330 Series, 136.8" W.B., All w/Manual Trans. DRW	TC to FA	913764-2109	E5TZ-4A376-C	32.750	Not Available	
1985 F350						
1330 Series, 133" W.B., All w/B.W., T19 Trans., Monobeam Axle SRW	TC to FA	913764-2109	E5TZ-4A376-C	32.750	Not Available	
1330 Series, 133" W.B., All w/5.8L Eng., All w/Automatic Trans., Monobeam Axle SRW	TC to FA	913764-2025	E5TZ-4A376-B	32.250	Not Available	

TC to FA — Transfer Case to Front Axle
TC to RA — Transfer Case to Rear Axle

YEAR/MAKE/MODEL DESCRIPTION	LOCATION	SPICER WELDED ASSEMBLY NUMBER	OEM NUMBER	CENTERLINE TO CENTERLINE OF CROSS (Collapsed Lengths)	SPICER UNWELDED ASSEMBLY	
					PART NUMBER	TUBE LENGTH REQUIRED
FORD (Continued)						
1979 F250, F350						
1330 Series, Part Time Transfer Case, 351, 400 Eng. w/Automatic Trans. and 133" Wheel Base	TC to FA	910721-1618	D9TZ-4602-W	28.031	Not Available	
1330 Series, Part Time Transfer Case, 300 Eng. w/Manual Trans. and 133" & 155" Wheel Base	TC to FA	910721-1209	D9TZ-4602-Y	23.750	Not Available	
1330 Series, Full Time Transfer Case, 351, 400 Eng. w/Automatic Trans.	TC to FA	910721-1912	D9TZ-4602-X	30.844	Not Available	
1330 Series, Full Time Transfer Case, 351, 400 Eng. w/Automatic Trans. and 133" & 155" Wheel Base	TC to FA	910721-1801	D9TZ-4602-AA	29.500	Not Available	
1979 F250, F350 WITH SNOW PLOW OPTION						
1330 Series, Part Time Trans. Case, 351, 400 Eng. w/Auto. Trans. and 133" & 155" Wheel Base	TC to FA	910721-1507	D9TZ-4602-Z	26.688	Not Available	
1998 RANGER						
2.3L, 3.0L, 4.0L Automatic and manual trans All WB	TC to RA	032DS85002-2331	F77A-4A376-BB	N/A	Not Available	
1995-97 RANGER						
1310 Series All W.B., Automatic & Manual Trans 2.3L, 3.0L	TC to FA	918490-1827	F37A-4A376-CB F37A-4A376-C	30.750	Not Available	
1310 Series All W.B., Automatic & Manual Trans 4.0L	TC to FA	918490-1717	F37A-4A376-BB F37A-4A376-B	29.406	Not Available	
1310 Series All W.B., All Trans All Engines	TC to RA	919220-2715	F57A-4602-AC	40.500	Not Available	
1993-94 RANGER						
1310 Series Short W.B., 4-Spd. Auto. 5-Spd. Manual, 2.3L, 3.0L, 4.0L	TC to FA	918490-1827	F37A-4A376-CB	30.750	Not Available	
1310 Series Short W.B., 4-Spd. Auto., 5-Spd. Manual, 2.3L, 3.0L, 4.0L	TC to RA	915983-2812	F37A-4602-PA	40.540	Not Available	
1310 Series Short W.B., 4-Spd. Auto., 5-Spd. Manual, 4.0L	TC to FA	918490-1717	F37A-4A376-BB F37A-4A376-B	29.440	Not Available	
1310 Series Long W.B., 4-Spd. Auto., 5-Spd. Manual, 2.3L, 3.0L	TC to FA	918490-1827	F37A-4A376-CB F37Z-4A376-C	30.750	Not Available	
1310 Series Long W.B., 4-Spd. Auto., 4-Spd. Automatic, 5-Spd. Manual, 4.0L	TC to FA	918490-1717	F37A-4A376-BB F37A-4A376-B	29.440	Not Available	
1310 Series Super Cab, 4-Spd. Auto., 5 Spd. Manual, 2.3L, 3.0L	TC to FA	918490-1827	F37A-4A376-CB F37Z-4A376-C	30.750	Not Available	
1310 Series Super Cab, 4-Spd. Auto., 5 Spd. Manual, 4.0L	TC to FA	918490-1717	F37A-4A376-BB F37A-4A376-B	29.440	Not Available	
1990-92 RANGER						
1310 Series Short W.B. 4-Spd. Auto., 5-Spd. Manual, 2.3L, 2.9L, 4.0L	TC to FA	918490-1717	F37A-4A376-BB F37A-4A376-B	29.440	Not Available	
1310 Series Short W.B. 4-Spd. Auto., 5-Spd. Manual, 2.3L, 2.9L, 4.0L	TC to RA	915983-2812	F07A-4602-CA	40.540	Not Available	
1310 Series Long W.B., 4-Spd. Auto., 5-Spd. Manual w/O.D., 2.3L, 2.9L, 4.0L	TC to FA	918490-1717	F37A-4A376-BB F37A-4A376-B	29.440	Not Available	
1310 Series Super Cab, 4-Spd. Auto., 4-Spd. Automatic, 5-Spd. Manual w/O.D., 2.3L, 2.9L, 4.0L	TC to FA	918490-1717	F37A-4A376-BB F37A-4A376-B	29.440	Not Available	

TC to FA — Transfer Case to Front Axle
TC to RA — Transfer Case to Rear Axle

YEAR/MAKE/MODEL DESCRIPTION	LOCATION	SPICER WELDED ASSEMBLY NUMBER	OEM NUMBER	CENTERLINE TO CENTERLINE OF CROSS (Collapsed Lengths)	SPICER UNWELDED ASSEMBLY	
					PART NUMBER	TUBE LENGTH REQUIRED
FORD (Continued)						
1989 RANGER						
1310 Series Short W.B., 4-Spd. Auto., 5-Spd. Manual, 2.3L, 2.9L	TC to RA	915554-2828	E97A-4602-AB	40.570	Not Available	
1210/1310 Series Short W.B., 4-Spd. Automatic, 5-Spd. Manual w/STX Trim Package, 2.9 L.	TC to FA	914887-1423	E77A-4A376-DA E7TZ-4A376-B	26.500	Not Available	
1210/1310 Series Short W.B., 4-Spd. Automatic, 5-Spd. Manual w/STX Trim Package, 2.9 L.	TC to RA	915554-2828	E97A-4602-AB E9TZ-4602-H	40.570	Not Available	
1210 Series Long W.B., 4-Spd. Automatic, 5-Spd. Manual w/STX Trim Package, 2.9L	TC to FA	914887-1423	E77A-4A376-DA	26.500	Not Available	
1210 Series Super Cab, 4-Spd. Auto., 5-Spd. Man. w/STX Trim Package, 2.9L	TC to FA	914887-1423	E77A-4A376-DA E7TZ-4A376-B	26.500	Not Available	
1988 RANGER						
1210 Series Short W.B., 4-Spd. Automatic, 5-Spd Manual w/STX Trim Package, 2.3L, 2.9L	TC to RA	914110-2814	E77A-4602-AFA	39.810	919990-3400	26.25
1210 Series, 4-Spd. Auto., 5-Spd. Manual w/STX Trim Package, 2.9L	TC to FA	914887-1423	E77A-4A376-DA E7TZ-4A376-B	26.500	Not Available	
1987 RANGER						
1210 Series, 4-Spd. Automatic w/STX Trim Package, 2.9L	TC to FA	914887-1423	E77A-4A376-DA E7TZ-4A376-B	26.500	Not Available	
1210 Series Short W.B, 4-Spd. Auto. w/STX Trim Package, 2.9L	TC to RA	914110-2814	E77A-460Z-AFA	39.810	919990-3400	26.25
1210 Series, 5-Spd. Manual w/O.D., w/STX Trim Package, 2.9L	TC to FA	914887-1207	E77A-4A376-CA E7TZ-4A376-A	24.000	Not Available	
1210 Series, 5-Spd. Manual w/O.D., 2.9L	TC to FA	914887-1423	E77A-4A376-DA E7TZ-4A376-B	26.500	Not Available	
1210 Series Short W.B., 5-Spd. Man. w/O.D., 2.3L, 2.9L; 2.9L w/STX Trim Package	TC to FA	914110-3029	E77A-4602-AEA E5TZ-4602-T	42.280	919990-3400	28.72
1986 RANGER						
1210 Series Short W.B., 4-Spd. Automatic, 2.9L	TC to RA	914282-2827	E67A-4602-EA E6TZ-4602-F	40.210	919976-3400	26.66
1210 Series Short W.B., 5-Spd. Manual w/O.D., 2.3L, 2.3D	TC to RA	914282-3110	E67A-4602-GA E6TZ-4602-H	42.680	919976-3400	29.12
1983-85 RANGER						
1210 Series Short W.B., C5 Automatic w.2.8L, M4 Manual w/2.3L, 2.8L	TC to RA	913633-3228	E47A-4602-LA E3TZ-4602-AB E37A-4602-FB	44.250	919990-3400	30.69
1210 Series Short W.B., 5-Spd. Manual w/O.D., 2.3L, 2.8L, 2.3D	TC to RA	913633-3029	E37A-4602-JB E3TZ-4602-AC	42.280	919990-3400	28.72
1985 RANGER						
1210 Series Short W.B., 4-Spd. Automatic, 2.3L, 2.8L	TC to RA	913633-2814	E57A-4602-JB E5TZ-4602-U	39.810	919990-3400	26.25
ISUZU						
1999 RODEO/AMIGO						
6 Cyl. Engine, Man. trans.	TC to FA	920683-0208	8971253012	17.53	Not Available	
1999 RODEO/AMIGO						
6 Cyl. Engine, Auto trans.	TC to FA	920694-0824	8971253022	24.03	Not Available	
1999 FRONTERA						
4 Cyl. Engine, Man. trans. Long W.B.	TC to FA	920694-0116	8971253031	13.890	Not Available	
1998-99 RODEO/AMIGO						
4 Cyl. Engine, Man. trans.	TC to FA	920694-0116	8971253031	13.890	Not Available	

TC to FA — Transfer Case to Front Axle
TC to RA — Transfer Case to Rear Axle

YEAR/MAKE/MODEL DESCRIPTION	LOCATION	SPICER WELDED ASSEMBLY NUMBER	OEM NUMBER	CENTERLINE TO CENTERLINE OF CROSS (Collapsed Lengths)	SPICER UNWELDED ASSEMBLY	
					PART NUMBER	TUBE LENGTH REQUIRED
JEEP Short W.B.						
1997-2000 WRANGLER						
1310 Series 4.0L eng. w/ auto Trans. 2.5L engine w/auto & 4 Spd 231/242 Extensionless TC 1.75" O.D. driveshaft tubing	TC to FA	919376-2412	52098378	37.950	Not Available	
1310 Series 4.0L engine w/ 5 Spd Manual Model 30 Dana front axle 231/242 Extensionless TC 2.50" O.D. driveshaft tubing	TC to FA	919374-2521	52098377	39.490	Not Available	
1997-98 GRAND CHEROKEE						
1310 Series, 4.0L Engine Auto trans. 242 TC Dana model 30 Front <i>* Requires the installation of 2-4-6561-1 at axle input</i>	TC to FA	919376-1806*	52098707	31.750	Not Available	
1996-98 GRAND CHEROKEE						
1310 Series, 5.2L, 5.9L Engine Auto. trans., 249 TC Dana model 30 Front Axle <i>* Requires the installation of 2-4-6561-1 at axle input</i>	TC to FA	919376-1601*	56022666AA	29.600	Not Available	
1996 1/2-97 GRAND CHEROKEE						
1310 Series, 4.0L Engine Auto trans., 249 TC Dana model 30 Front Axle	TC to FA	919649-1412	52099260	31.530		
1310 Series, 2.5 L Engine, Manual 5-Spd., 231 T/C Model 30 Dana Front Axle Driveshaft w/2.000" tubing	TC to FA	919373-1510	52098706	29.020	Not Available	
1310 Series, 5.2 L Engine, Automatic, 249 T/C Model 30 Dana Front Axle Driveshaft Dbl. Crd and CV Joint <i>Not available as an assembly. CV head assembly is only servicable part. See important notes on Bill of Material page, PG. 23</i>	TC to FA	919649-1204	52098379	—	Not Available	
1995 1/2-96 GRAND CHEROKEE						
1310 Series, 4.0 L Engine, I-6 Auto., 249 T/C Model 30 Dana Front Axle Driveshaft Dbl. Crd and CV Joint <i>Not available as an assembly. CV head assembly is only servicable part. See important notes on Bill of Material page, PG. 23</i>	TC to FA	919649-1412	52099260	—	Not Available	
1996 GRAND CHEROKEE						
1310 Series, 4.0 L Engine, Man. 5-Spd., 242 T/C Model 30 Dana Front Axle Driveshaft w/1.750" tubing	TC to FA	919376-1806	52098707	31.770	Not Available	
1310 Series, 4.0 L Engine, Man. 5-Spd., 231 T/C Model 30 Dana Front Axle Driveshaft w/2.000" tubing	TC to FA	919373-1410	52098789	28.020	Not Available	
1310 Series, 2.5 L Engine, Man. 5-Spd., 231 T/C Model 30 Dana Front Axle Driveshaft w/2.000" tubing	TC to FA	919373-1410	52098789	28.020	Not Available	
1310 Series, 5.2 L Engine, Auto., 249 T/C Model 30 Dana Front Axle Driveshaft Dbl. Crd and CV Joint <i>Not available as an assembly. CV head assembly is only servicable part. See important notes on Bill of Material page, PG. 23</i>	TC to FA	919649-1104	52099246	—	Not Available	
1995 1/2-96 GRAND CHEROKEE						
1310 Series, 4.0 L Engine, I-6 Auto., 249 T/C Model 30 Dana Front Axle Driveshaft Dbl. Crd and CV Joint <i>Not available as an assembly. CV head assembly is only servicable part. See important notes on Bill of Material page, PG. 23</i>	TC to FA	919649-1312	52098850	—	Not Available	

TC to FA — Transfer Case to Front Axle
TC to RA — Transfer Case to Rear Axle

YEAR/MAKE/MODEL DESCRIPTION	LOCATION	SPICER WELDED ASSEMBLY NUMBER	OEM NUMBER	CENTERLINE TO CENTERLINE OF CROSS (Collapsed Lengths)	SPICER UNWELDED ASSEMBLY	
					PART NUMBER	TUBE LENGTH REQUIRED
JEEP Short W.B. (Continued)						
1995 1/2 GRAND CHEROKEE						
1310 Series, 5.2 L Engine, Auto., 249 T/C Model 30 Dana Front Axle Driveshaft Dbl. Crd and CV Joint <i>Not available as an assembly. CV head assembly is only servicable part. See important notes on Bill of Material page, PG. 23</i>	TC to FA	919649-1520	52098501	—	Not Available	
1993-95 1/2 GRAND CHEROKEE						
1310 Series, 5.2L Engine, V-8 Auto., 231, 249 T/C, Model 30 Dana Front Axle	TC to FA	918291-2111	53008427	32.870	Not Available	
1993-95 1/2 GRAND CHEROKEE						
1310 Series, 4.0L Eng., V-8 Auto., 231, 242, 249 T/C, Model 30 Dana Front Axle	TC to FA	918291-1900	52087805	30.530	Not Available	
1992 1/2-95 GRAND CHEROKEE						
1310 Series, 4.0 L Eng, Man. 5-Spd., 231 T/C, Model 30 Dana Front Axle	TC to FA	915374-1614	52088090	28.020	Not Available	
1992 1/2-93 GRAND CHEROKEE AND GRAND WAGONEER						
1310 Series, 4.0L Engine Aisen Warner, 231, 242, 249 T.C., Model 30 Dana Front Axle	TC to FA	915374-1724	52098341	30.530	Not Available	
1999-2000 CHEROKEE						
1310 Series, 2.1L & 2.5L Eng. Aisen, Man. 5-Spd., 231 T/C, Model 30 Dana Axle	TC to FA	915723-1318	53005541	25.310	Not Available	
1310 Series, 4.0L Eng. Aisen Seiki, Man. 5-Spd., Kanda T/C, Model 44 Dana Axle	TC to FA	915374-1517	53005544	27.080	Not Available	
1310 Series, 4.0L Eng. Aisen Warner, Auto. 4-Spd., Kanda T/C, Model 44 Dana Axle	TC to FA	915374-1702	53005545	28.620	Not Available	
1999 CHEROKEE						
1310 Series, 4.0L Eng. Aisen Warner, 4-Spd. Auto, 231 T/C & 242 T/C, Model 30 Dana Front Axle	TC to FA	915374-1903	53005542	30.660	Not Available	
1310 Series, 4.0L Eng. Aisen Seiki, Man. 5-Spd., 231/Kanda T/C, Model 30 Dana Axle	TC to FA	915374-1722	53005543	29.250	Not Available	
1995-2000 CHEROKEE						
1310 Series, 2.5L Turbo Eng. Manual 5-Spd., 231 T/C, Model 30 Dana Front Axle	TC to FA	915374-1602	52098208	27.640		
1995-98 CHEROKEE						
1310 Series, 2.1L & 2.5L Eng. Aisen, Manual 5-Spd., 231 T/C, Model 30 Dana Axle	TC to FA	915723-1318	53005541	25.310	Not Available	
1310 Series, 4.0L Eng. Aisen Warner, 4-Spd. Auto, 231 T/C & 242 T/C, Model 30 Dana Front Axle	TC to FA	915374-1903	53005542	30.660	Not Available	
1310 Series, 4.0L Eng. Aisen Seiki, Man. 5-Spd., 231/Kanda T/C, Model 30 Dana Axle	TC to FA	915374-1722	53005543	29.250	Not Available	
1310 Series, 4.0L Eng. Aisen Seiki, Man. 5-Spd., Kanda T/C, Model 44 Dana Axle	TC to FA	915374-1517	53005544	27.080	Not Available	
1310 Series, 4.0L Eng. Aisen Warner, Auto. 4-Spd., Kanda T/C, Model 44 Dana Axle	TC to FA	915374-1702	53005545	28.620	Not Available	

TC to FA — Transfer Case to Front Axle

TC to RA — Transfer Case to Rear Axle

YEAR/MAKE/MODEL DESCRIPTION	LOCATION	SPICER WELDED ASSEMBLY NUMBER	OEM NUMBER	CENTERLINE TO CENTERLINE OF CROSS (Collapsed Lengths)	SPICER UNWELDED ASSEMBLY	
					PART NUMBER	TUBE LENGTH REQUIRED
JEEP Short W.B. (Continued)						
1990-94 CHEROKEE, COMANCHE, AND WAGONEER						
1310 Series, 2.5L Engine, Auto. Trans., 231 T/C, Model 30 Dana Front Axle	TC to FA	915723-1607	53005540	27.970	Not Available	
1310 Series, 2.1L & 2.5L Eng. Aisen, Man. 5-Spd., 231 T/C, Model 30 Dana Axle	TC to FA	915723-1318	53005541	25.310	Not Available	
1310 Series, 4.0L Eng. Aisen Warner, 4-Spd. Auto, 231 T/C & 242 T/C, Model 30 Dana Front Axle	TC to FA	915374-1903	53005542	30.660	Not Available	
1310 Series, 4.0L Eng. Aisen Seiki, Man. 5-Spd., 231/Kanda T/C, Model 30 Dana Axle	TC to FA	915374-1722	53005543	29.250	Not Available	
1310 Series, 4.0L Eng. Aisen Seiki, Man. 5-Spd., Kanda T/C, Model 44 Dana Axle	TC to FA	915374-1517	53005544	27.080	Not Available	
1310 Series, 4.0L Eng. Aisen Warner, Auto. 4-Spd., Kanda T/C, Model 44 Dana Axle	TC to FA	915374-1702	53005545	28.620	Not Available	
1990-91 SENIOR JEEP (GRAND WAGONEER)						
1310 Series, 5.9L Eng., 727 Auto. Trans., 229 T/C, Model 44 Dana Axle	TC to FA	915724-1427	53005539	25.700	Not Available	
1988 CHEROKEE, COMANCHE, AND WAGONEER						
1310 Series, 6 Cyl. Eng. Peugeot, Automatic Trans., Kanda P.t. Trans. Case, 4.11 Axle Ratio	TC to FA	915723-1607	8953003912	27.953	909364-2600	16.219
1310 Series, 4 Cyl. Eng. Aisen, 4 & 5-Spd. Manual Trans., 3.55 & 4.11 Axle Ratios, 231 Transfer Case	TC to FA	915723-1318	8953003235	25.313	909364-2600	13.563
1310 Series, 6 Cyl. Eng., Auto. Trans., 242/231 Trans. Cases, 3.55 Axle Ratio	TC to FA	915374-1903	8953005040	30.672	Not Available	
1310 Series, 6 Cyl. Eng. Peugeot, Automatic Trans., 242/231 Trans, Cases, 3.08 Axle Ratio	TC to FA	915374-1722	8953005039	29.250	Not Available	
1982-83 CHEROKEE, WAGONEER, J10						
1310 Series, 6 Cyl. w/5-Spd.	TC to FA	915724-1714	5363399	28.969	Not Available	
1982-83 CJ10						
1310 Series, Automatic Trans.	TC to FA	915724-1921	5994167	31.188	Not Available	
1310 Series, Manual Trans.	TC to FA	915724-1620	5994166	28.188	Not Available	
1980-83 CHEROKEE, WAGONEER, J10						
1310 Series, 6 Cyl., Automatic	TC to FA	911334-1721	5360997	29.188	Not Available	
1310 Series, 6 Cyl. & V-8, 4-Spd. Man. Trans.	TC to FA	915724-1427	5360995	26.375	Not Available	
1980-83 J20						
Trans.		915724-1721				
1310 Series, V-8, Automatic Trans.	TC to FA	915724-1405	5360996	25.688	Not Available	
1310 Series, 6 Cyl. & V-8, 4-Spd. Trans., 131" Wheel Base	TC to FA	915724-2328	5360998	35.406	Not Available	
1979 WAGONEER, J10, J20						
1310 Series, 6 Cyl., 3-Spd. Trans.	TC to FA	915723-0908	5359384	21.000	909364-2600	9.25
1310 Series, V-8, 3-Spd. Trans.	TC to FA	915723-0808	5359383	20.000	909364-2600	8.25
1310 Series, 6 Cyl., Hydramatic Trans.	TC to FA	915723-1708	5359385	29.000	909364-2600	17.25
1310 Series, 4-Spd. Trans., V-8, Hydramatic Trans.	TC to FA	915723-1308	5359386	25.000	909364-2600	13.25

TC to FA — Transfer Case to Front Axle
TC to RA — Transfer Case to Rear Axle

YEAR/MAKE/MODEL DESCRIPTION	LOCATION	SPICER WELDED ASSEMBLY NUMBER	OEM NUMBER	CENTERLINE TO CENTERLINE OF CROSS (Collapsed Lengths)	SPICER UNWELDED ASSEMBLY	
					PART NUMBER	TUBE LENGTH REQUIRED
JEEP Short W.B. (Continued)						
1979 CJ-7						
1310 Series, Automatic Trans.	TC to FA	915723-2426	5359382	36.563	909364-2600	24.813
1978 WAGONEER, J10, J20						
1310 Series, 6 Cyl., Hydramatic Trans.	TC to FA	915723-1708	5356506 5352119	29.000	909364-2600	17.25
1310 Series, 4-Spd. Trans, V-8 w/ Hydramatic Trans.	TC to FA	915723-1308	5358684	25.000	909364-2600	13.25
1978 CJ-7						
1310 Series w/Automatic Transmission	TC to FA	915723-2426	5355573 5359382	36.563	909364-2600	24.813
1976-77 CJ-7						
1310 Series	TC to FA	915723-2426	535573	36.563	909364-2600	24.813
1974-77 CHEROKEE, WAGONEER, J10, J20						
1310 Series, 6 Cyl. & V-8, 3-Spd. . Trans	TC to FA	915723-0808	5359383 5356503	20.000	909364-2600	8.25
1310 Series, 6 Cyl. & V-8, 4-Spd. Trans., V-8 Hydramatic Trans., Quadratrac	TC to FA	915723-1221	5356505	24.406	909364-2600	12.656
J10, J20						
1310 Series, 6 Cyl., Hydramatic Trans, Quadratrac	TC to FA	915723-1708	5352119 5356506	29.000	909364-2600	17.25
1973 J10, J20						
1310 Series, V6, Automatic Trans.	TC to FA	915723-1924	5351017	31.500	909364-2600	19.75
1972-73 J10, J20						
1310 Series, V-8, Automatic Trans.	TC to FA	915723-1516	5351018	27.250	909364-2600	15.5
1971-73 J10, J20						
1310 Series, 350 V-8 Eng., 4-Spd. Automatic Trans.	TC to FA	915723-1324	5351019	25.500	909364-2600	13.75
PONTIAC						
1988 6000 STE						
1210 Series, All Wheel Drive, Full Time Trans. Case, Two piece rear shaft is supplied by GM, has Ball Style C.V. Joint at Trans. Case, a Single Cardan Joint at the Rear Axle, and a Spicer Double Cardan Head Assy. at Rear of Coupling Shaft	TC to RA	913797	—	—	—	—

TC to FA — Transfer Case to Front Axle
TC to RA — Transfer Case to Rear Axle

SPICER HEAD ASSEMBLIES

NON-GREASABLE STYLE

- Prelubed at factory.
- Maintenance free — no service interval.
- Centering kit sealing package improved for lube retention.
- Improved outer wiper seal keeps contaminants out.
- No loss of operating angle potential in head assemblies.

GREASABLE STYLE

- Can be greased with special needle-nose type grease gun attachment.
- Service at normal driveshaft maintenance intervals of 2,000 to 3,000 miles, or one month, whichever comes first.

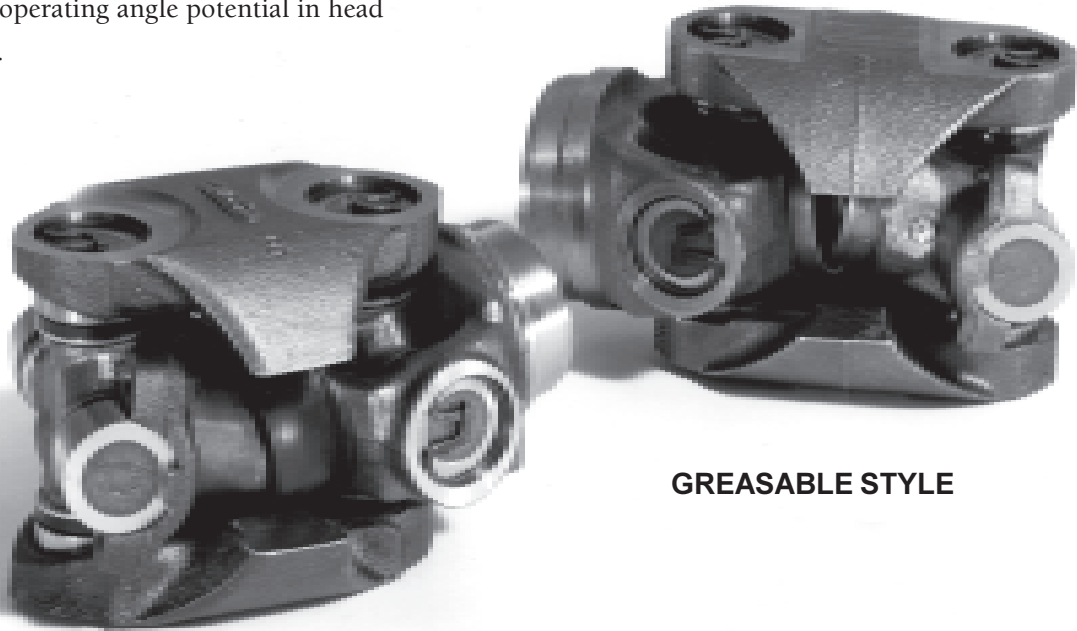

NON-GREASABLE STYLE

GREASABLE STYLE

SOCKET YOKE ASSEMBLY DIMENSIONAL DATA

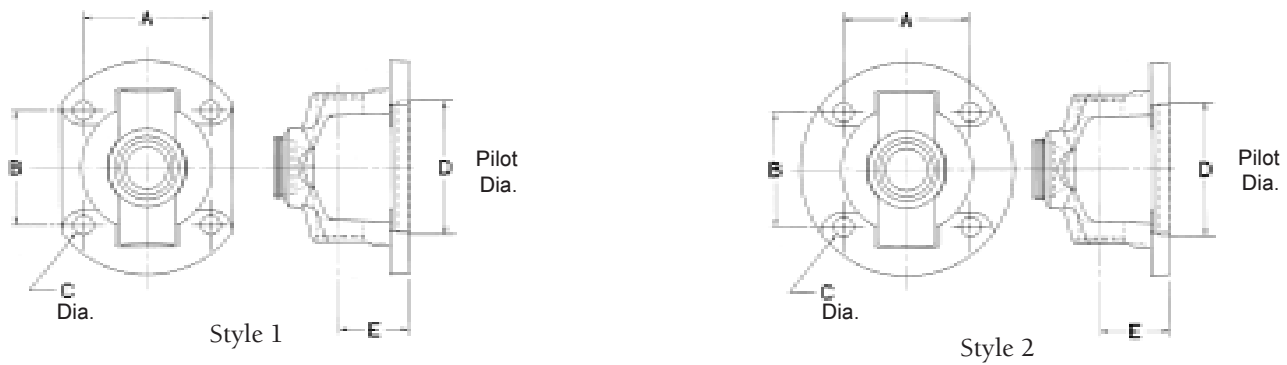

Flanged Socket Yoke Assembly	Series	Style	Bolt Circle Diameter	Bolt Holes Dimension			D	E	Fits Ball Stud Size
				A	B	C			
211489X ●	1210	1	3.50	2.468	2.468	.484	2.000	1.625	.500
211543X ■ ‡	1310	1	3.50	2.484	2.484	.484	2.000	1.625	.500
211229X ■ ▶	1310	1	3.50	2.484	2.484	.484	2.000	1.625	.500
211452X ●	1310	1	4.25	3.000	3.000	.453	3.125	1.625	.500
211198X ●	1310	1	4.00	2.937	2.937	.453	3.125	1.625	.500
211545X ■	1310	1	4.25	3.000	3.000	.453	3.125	1.625	.500
212040X	1310	1	4.25	3.00	3.00	.488	3.126	1.620	.500
211631X ■	1330	1	4.25	3.000	3.000	M12X1.75th'd	2.000	1.625	.500
211913X ■	1330	1	4.25	3.000	3.000	.462	3.125	1.625	.500
211889X ●	1330	2	4.00	2.953	2.656	.453	3.125	1.875	.500
211606X	1330	2	4.00	2.953	2.656	.453	3.125	1.812	.500
211520X ●	1330	2	4.00	2.953	2.656	.453	3.125	1.875	.625
211868X ●	1330	2	4.25	3.000	3.000	.453	3.125	1.812	.500
212025X ■	1350	1	4.25	3.000	3.000	M12X1.75th'd	2.680	1.625	.500
212024X ■	1350	1	4.25	3.000	3.000	M12X1.75th'd	2.000	1.625	.500

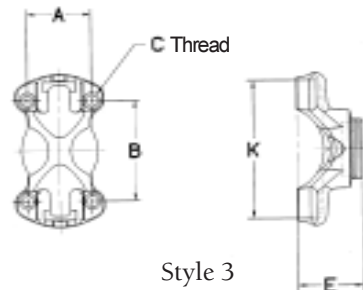

Socket Yoke Assembly	Series	Style	Bolt Holes Dimension				C/L To End E	Fits Ball Stud Size
			K	A	B	C		
211519X	1210	—	2.437	1.500	2.343	.250-28th'd	1.640	has .500 stud
211342X	1210	3	2.437	1.500	2.343	.250-28th'd	1.531	.500
211544X ■	1310	3	3.218	1.500	2.343	.312-24th'd	1.656	.500
211355X	1310	3	3.218	1.500	2.343	.312-24th'd	1.531	.500
210841X	1330	3	3.625	1.500	2.875	.312-24th'd	1.562	.625
211179X ●	1330	3	3.625	1.500	2.875	.312-24th'd	1.562	.500
211996X ■ ‡	1330	3	3.625	1.500	2.875	.312-24th'd	1.690	.500
212019X ■	1350	3	3.625	1.625	2.750	.312-24th'd	1.757	.500

FOOTNOTES: ● Flush Zerk (#230977) ▶ Socket OD 1.394
 ■ Non-Greasable ‡ Socket OD 1.625

HOW TO SERVICE DOUBLE CARDAN SOCKET YOKE ASSEMBLIES

1. Determine if assembly is Greasable (with lube fitting) or Non-Greasable
2. Determine style (End Yoke style or Flanged style)
3. Refer to chart below to determine Socket Yoke part number

End Yoke Style Socket Yoke

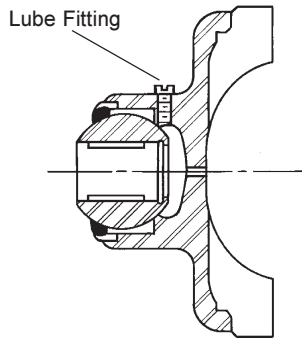

Greasable Style

Flanged Style Socket Yoke

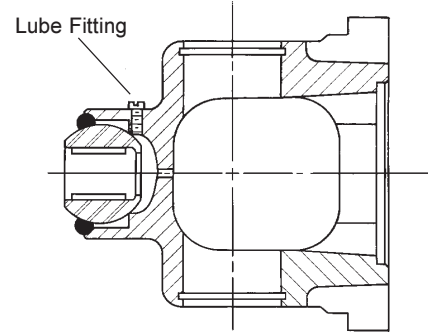

Greasable Style

When servicing driveshafts with non-greasable socket yokes, pack this cavity with grease before assembly.

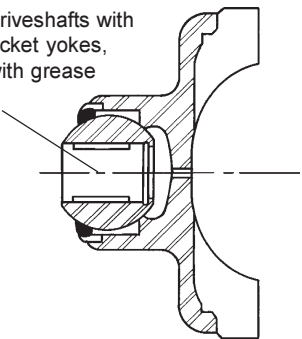

Non-Greasable Style

When servicing driveshafts with non-greasable socket yokes, pack this cavity with grease before assembly.

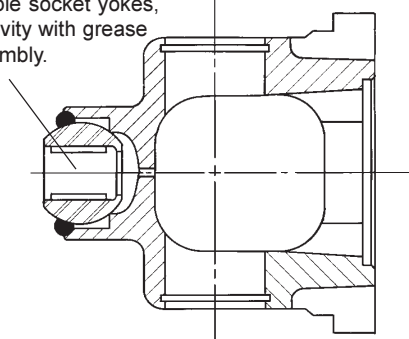

Non-Greasable Style

WELDED ASSEMBLY COMPONENT DRAWINGS

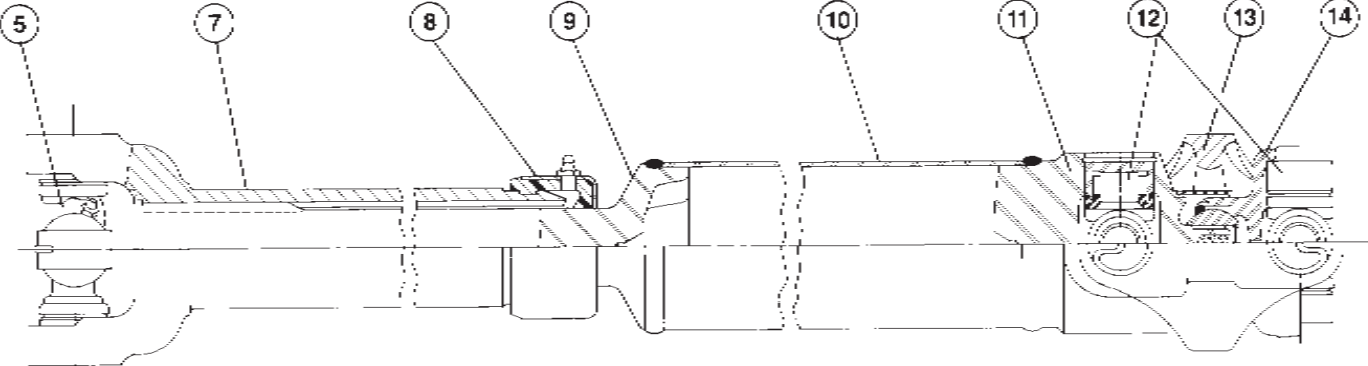

Fig. A

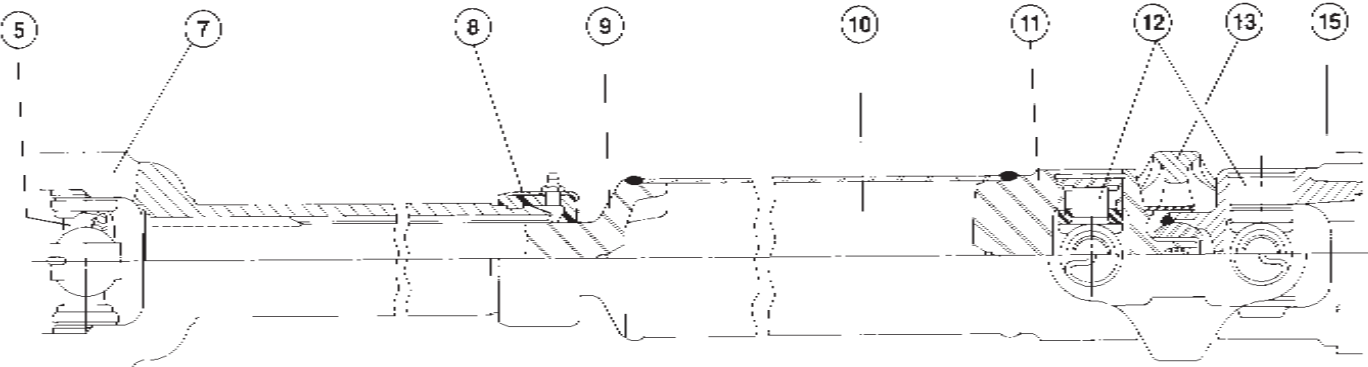

Fig. B

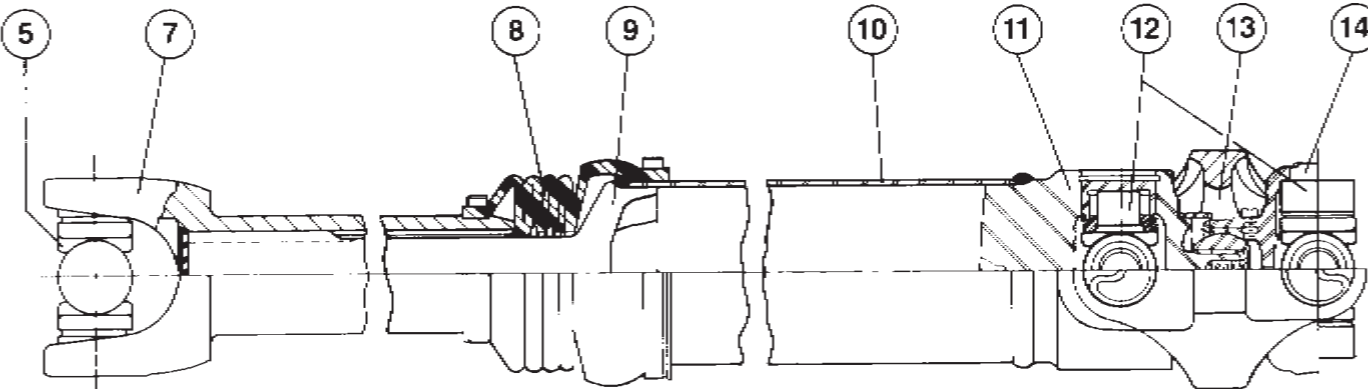

Fig. C

WELDED ASSEMBLY COMPONENT DRAWINGS

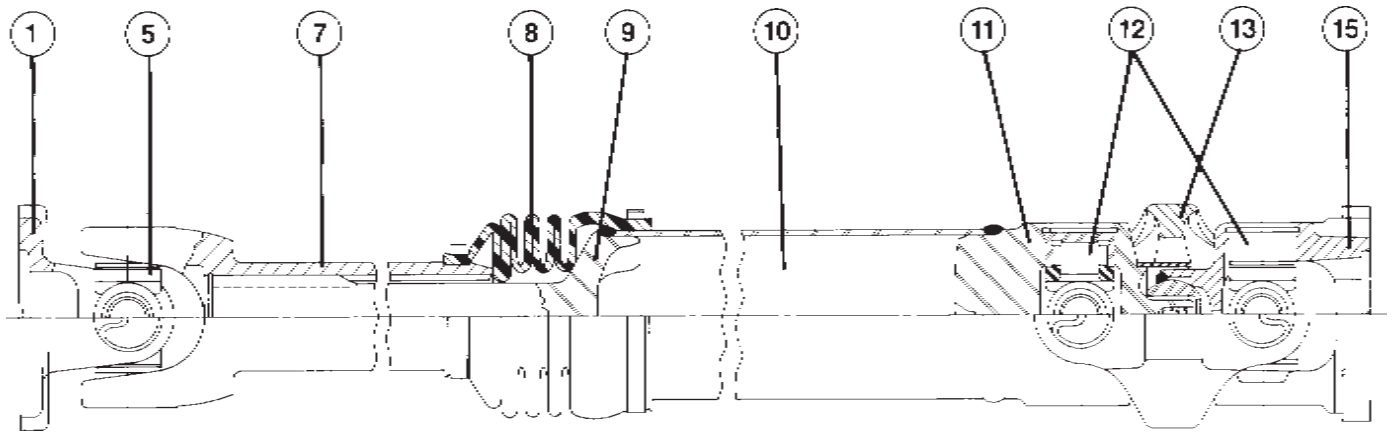

Fig. D

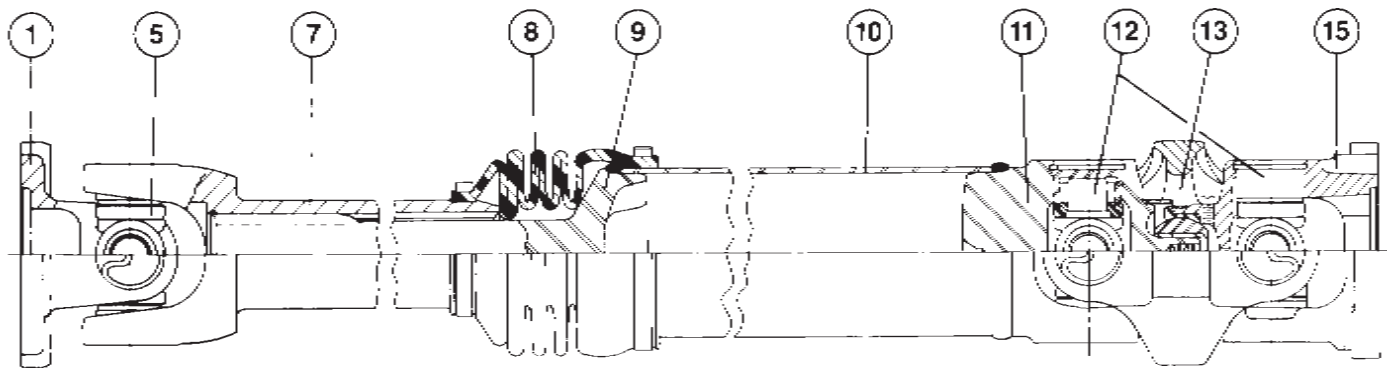

Fig. E

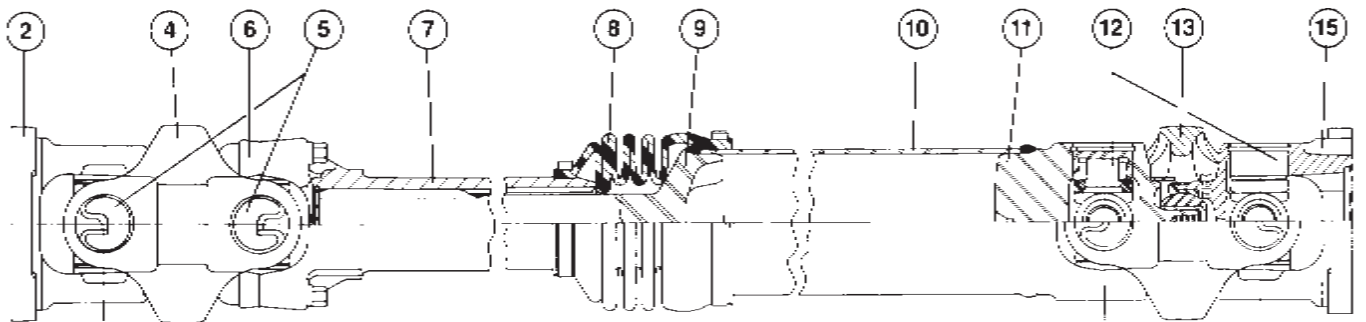

Fig. F

WELDED ASSEMBLY COMPONENT DRAWINGS

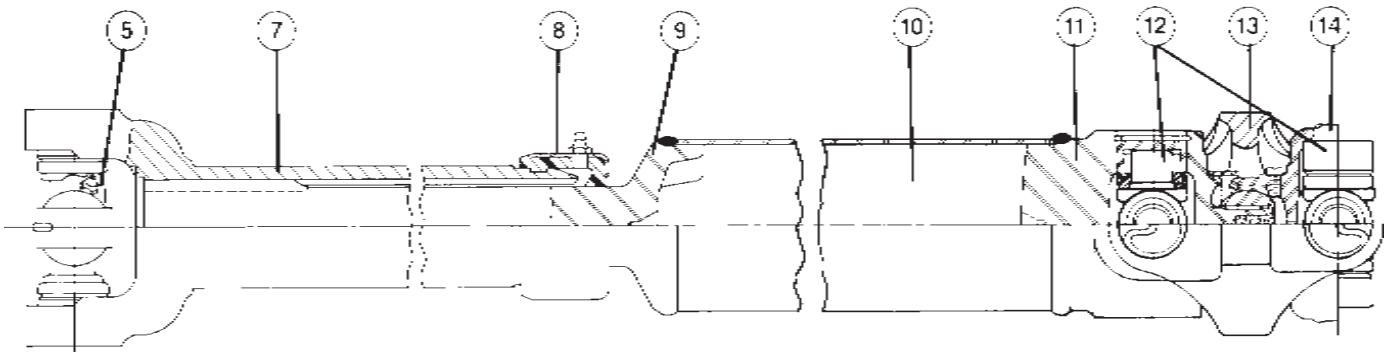

Fig. G

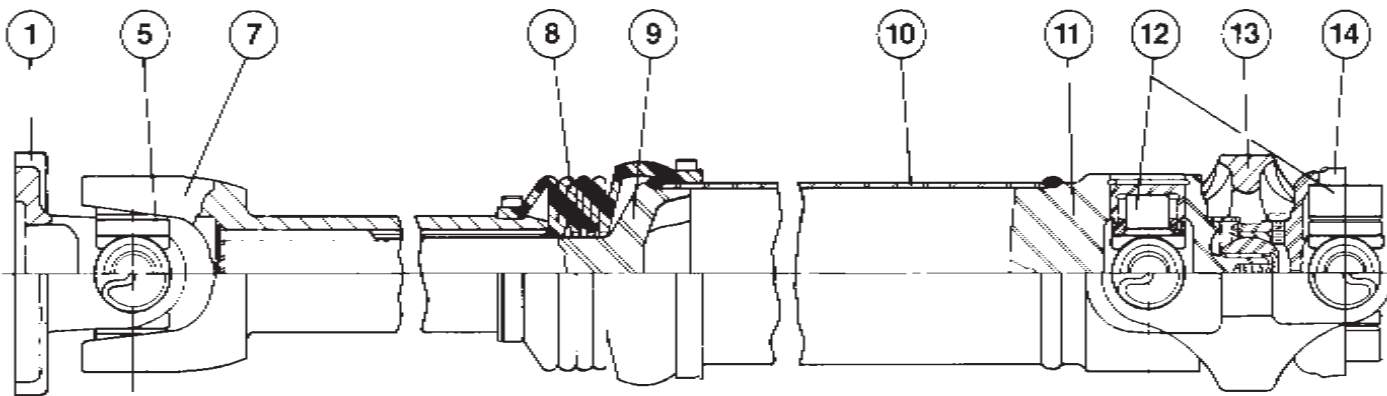

Fig. H

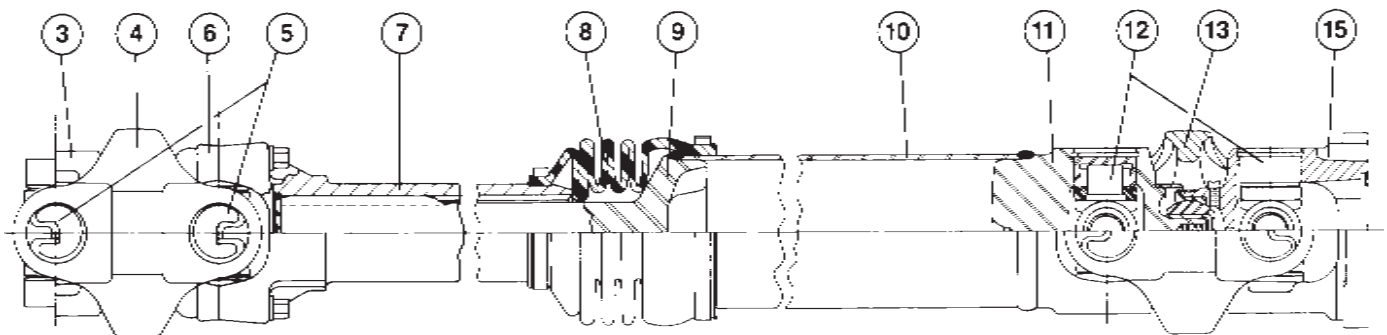

Fig. I

WELDED ASSEMBLY COMPONENT DRAWINGS

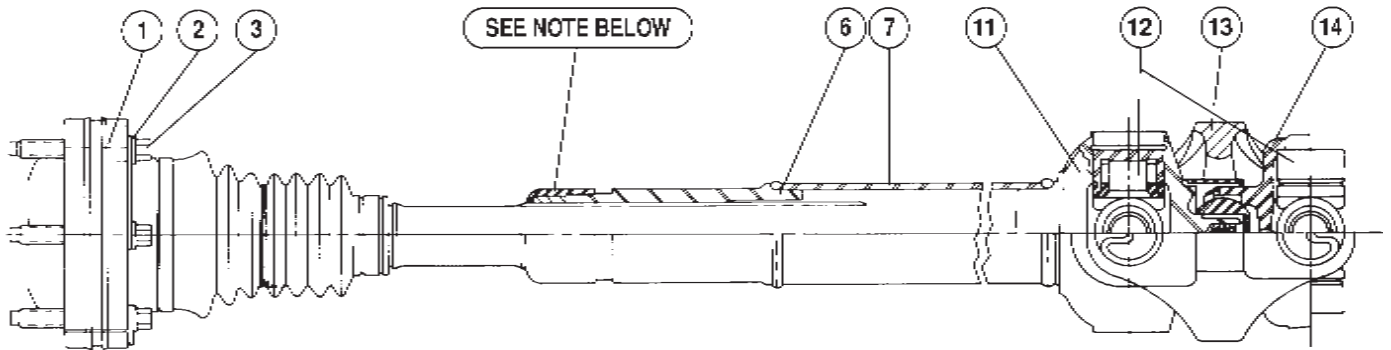

Fig. J

NOTE:

The installed length of this shaft is extremely critical.

Distributors are cautioned to inspect all 919649 driveshafts that come into their facility to determine if this nut has been loosened.

If the nut has been loosened, the installed length of the driveshaft has been compromised. **DO NOT** attempt to service a driveshaft where the nut has been loosened.

Have owner return the driveshaft and vehicle to the OEM dealer for replacement of the driveshaft and special installation.

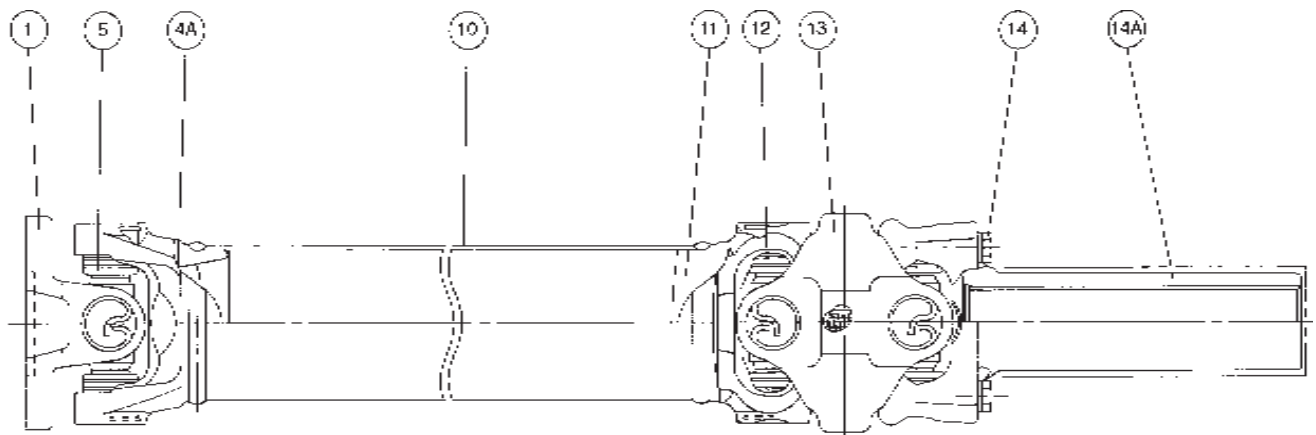

Fig. K

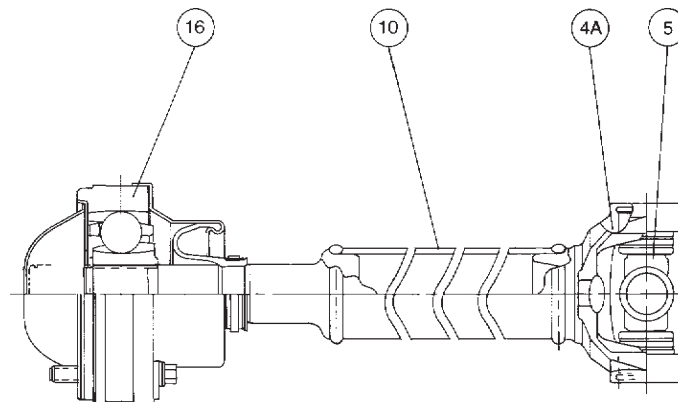

Fig. L

BILL OF MATERIAL

Part Number	Series	Fig.	4A Tube Yoke	5 U-Joint 1 Req'd.	10 Tubing●	16 Spicer CV Joint	Bolts Qty. (4)
032DS85002	SG32/1310	L	2-28-3187	5-625X	14-30-62	032SG80002	211982X

● Refer to Application section for appropriate tube length.

WELDED ASSEMBLY BILLS OF MATERIAL

Part Number	Series	Fig.	1 Flange Yoke	2 Flanged Socket Yoke (Centering Kit)	3 Socket Yoke (Centering Kit)	4 Center Yoke	4A Tube Yoke	5 U-Joint *≠1 Req'd **= 2 Req'd	6 Ball Stud Socket Yoke Assembly	7 Slip Yoke Assembly	8 Dust Cap kit or Boot Kit Ass'y.
• 903406	1310	A	-	-	-	-	-	5-153X*	-	2-3-8001KX	211121X
• 903862	1310	A	-	-	-	-	-	5-153X*	-	2-3-8001KX	211121X
• 904084	1310	A	-	-	-	-	-	5-255X*	-	2-3-4951KX	D2M
905026	1310	G	-	-	-	-	-	5-153X*	-	2-3-4951KX	D2C
905027	1310	G	-	-	-	-	-	5-153X*	-	2-3-8021KX	211121X
• 906638	1310	A	-	-	-	-	-	5-153X*	-	2-3-4951KX	D2M
• 907545	1310	A	-	-	-	-	-	5-153X*	-	2-3-8021KX	211121X
• 907758	1310	A	-	-	-	-	-	5-153X*	-	2-3-8021KX	211121X
• 908083	1310	A	-	-	-	-	-	5-625X*	-	2-3-7981KX	211121X
• 909762	1310	A	-	-	-	-	-	5-625X*	-	2-3-4951KX	D2M
• 910255	1310	A	-	-	-	-	-	5-153X*	-	2-3-8021KX	211121X
• 910413	1310/1330	A	-	-	-	-	-	5-213X*	-	2-3-8041KX	211121X
• 910424	1310/1330	A	-	-	-	-	-	5-213X*	-	2-3-7961KX	211121X
• 910539	1310/1330	A	-	-	-	-	-	5-213X*	-	2-3-7961KX	211121X
910719	1330	G	-	-	-	-	-	5-1204X*	-	2-3-8041KX	211121X
910720	1330	G	-	-	-	-	-	5-1204X*	-	2-3-8041KX	211121X
910721	1330	G	-	-	-	-	-	5-213X*	-	2-3-7961KX	211121X
910722	1330	G	-	-	-	-	-	5-213X*	-	2-3-7961KX	211121X
910729	1310/1330	G	-	-	-	-	-	5-153X*	-	2-3-7981KX	211121X
• 912170	1310	B	-	-	-	-	-	5-153X*	-	2-3-8001KX	211121X
912637	1310	C	-	-	-	-	-	5-1204X*	-	2-3-8941X	211462X+
913633	1210	H	2-2-1049	-	-	-	-	5-443X*	-	2-3-8861X	211344X+
913682	1210	I	-	-	211342X	2-26-457	5-315X**	211519X	2-3-9681X	211344X+	211344X+
• 913764	1330	C	-	-	-	-	-	5-1204X*	-	2-3-8921X	211462X+
913797	1210	-	-	-	-	-	-	-	-	-	-
914110	1210	H	2-2-1049	-	-	-	-	5-443X*	-	2-3-8861X	211344X+
914155	1210	D	2-2-1049	-	-	-	-	5-443X*	-	2-3-8961X	211344X+
914282	1210	D	2-2-1049	-	-	-	-	5-443X*	-	2-3-8861X	211344X+
914778	1210	F	-	211489X	211342X	2-26-457	-	5-315X**	211519X	2-3-9681X	211344X+
914887	1210/1310	C	-	-	-	-	-	5-153X*	-	2-3-10411X	211463X+
• 915371	1310	A	-	-	-	-	-	5-353X*	-	2-3-10261X	211121X
• 915374	1310	A	-	-	-	-	-	5-153X*	-	2-3-8841KX	211256X
• 915554	1310	E	2-2-939-1	-	-	-	-	5-153X*	-	2-3-10661X	211344X+
915723	1310	A	-	-	-	-	-	5-153X*	-	2-3-8841KX	211256X
915724	1310	A	-	-	-	-	-	5-153X*	-	2-3-8841KX	211256X
• 915841	1330	E	2-2-1369	-	-	-	-	5-213X*	-	2-3-8941X	211462X+
• 915983	1310	E	2-2-1379	-	-	-	-	5-153X*	-	2-3-10661X	211344X+
• 918291	1310	G	-	-	-	-	-	-	-	2-3-8841KX	211256X
• 918490	1310	A	-	-	-	-	-	5-153X*	-	2-3-10411X	211600X+
• 918586	1310	B	-	-	-	-	-	-	-	2-3-10621KX	211121X
918813	1330	K	2-2-1369	-	-	-	2-28-1697	5-618X*	-	-	-
919220	1310	E	2-2-1379	-	-	-	-	5-625X*	-	2-3-12311X	211932X
919221	1310	A	-	-	-	-	-	5-625X*	-	2-3-12421X	211916X
919292	1310/1330	E	2-2-1369	-	-	-	-	-	-	2-3-11991X	211932X
919373	1310	A	-	-	-	-	-	5-625X*	-	2-3-11351X	211932X
919374	1310	A	-	-	-	-	-	5-625X*	-	2-3-11351X	211932X
919376	1310	A	-	-	-	-	-	5-625X*	-	2-3-11351X	211932X
919526	1350	K	3-2-1579	-	-	-	3-28-57	5-627X*	-	-	-
919649	1310	J■	-	-	-	-	-	-	-	-	-
919993	1310	A	-	-	-	-	-	5-625X*	-	2-3-10261KX	-
920260	1330	K	2-2-1369	-	-	-	2-28-1697	5-618X*	-	-	-
920267	1350	K	3-2-1579	-	-	-	-	5-627X*	-	-	-
920309	1310	A	-	-	-	-	-	5-625X*	-	2-3-12421X	211916X
• 920575	1350/1410	B	-	-	-	-	-	5-641X*	-	3-3-6041X	212007X
• 920694	1210/1310	E	2-2-1519	-	-	-	-	5-625X*	-	2-3-10411X	211916X
• 921007	1350	B	-	-	-	-	-	5-627X*	-	3-3-6201X	212010X
• 921716	SPL25/7290	B	-	-	-	-	-	SPL25-7X	-	2-3-14331X	211932X
• 921782	1330	B	-	-	-	-	-	SPL25-1X	-	2-3-14331X	211932X
032DS85002	SG32/1310	L	-	-	-	-	2-28-3187	5-625X*	-	-	-

* Indicates driveshaft assemblies with non greasable socket yoke assy's.

+ Indicates boot kit assembly number

■ See note on Illustration J, Pg. 27

WELDED ASSEMBLY BILLS OF MATERIAL

9 Tube Shaft	10 Tubing	11 Ball Stud Tube Yoke	12 U-Joint Kits 2 Req'd	13 Center Yoke	14 Socket Yoke (Centering kit)	14A Slip Yoke Assembly	15 Flanged Socket Yoke	16 Spicer CV Joint Assembly	CV Head	End Yoke Assy.	Bolts Qty. (4)
2-40-1711	20-30-22	2-28-2887X	5-278X**	2-26-497	211544X	-	-	-	915622	-	-
2-40-1701	16-30-102	2-28-2867X	5-278X**	2-26-497	211544X	-	-	-	918523	-	-
2-40-1711	20-30-22	2-28-2887X	5-278X**	2-26-497	211544X	-	-	-	915621	-	-
2-40-1711	20-30-22	2-28-2957X	5-278X**	2-26-497	211355X	-	-	-	904096	2-4-4061X	5-73-220(4)
2-40-1851	20-30-22	2-28-2957X	5-278X**	2-26-497	211355X	-	-	-	904096	2-4-4061X	5-73-220(4)
2-40-1711	20-30-22	2-28-2887X	5-278X**	2-26-497	211544X	-	-	-	915622	2-4-4061X	5-73-220(4)
2-40-1851	20-30-22	2-28-2887X	5-278X**	2-26-497	211544X	-	-	-	915621	2-4-4061X	5-73-220(4)
2-40-1871	24-30-42	2-28-2927X	5-278X**	2-26-497	211544X	-	-	-	907873	2-4-4061X	5-73-220(4)
2-40-1701	16-30-102	2-28-2947X	5-278X**	2-26-497	211544X	-	-	-	915444	-	-
2-40-1701	16-30-102	2-28-2867X	5-625X**	2-26-497	211544X	-	-	-	902959	-	-
2-40-1851	20-30-22	2-28-2887X	5-278X**	2-26-497	211544X	-	-	-	915622	2-4-4061X	5-73-220(4)
2-40-2051	24-30-32	2-28-2907X	5-278X**	2-26-497	211544X	-	-	-	915623	2-4-4061X	5-73-220(4)
2-40-1711	20-30-22	2-28-2887X	5-278X**	2-26-497	211544X	-	-	-	915622	2-4-4061X	5-73-220(4)
2-40-1701	16-30-102	2-28-2867X	5-278X**	2-26-497	211544X	-	-	-	918523	-	-
2-40-1851	20-30-22	2-28-2137X	5-213X**	2-26-527	211179X	-	-	-	920517	2-4-5441	5-73-220(4)
2-40-2051	24-30-32	2-28-2117X	5-213X**	2-26-527	211179X	-	-	-	910812	2-4-5441	5-73-220(4)
2-40-1811	20-30-22	2-28-2137X	5-213X**	2-26-527	211179X	-	-	-	910811	2-4-5441	5-73-220(4)
2-40-1701	16-30-102	2-28-2157X	5-213X**	2-26-527	211179X	-	-	-	910810	2-4-5441	5-73-220(4)
2-40-1701	16-30-102	2-28-2157X	5-213X**	2-26-527	211179X	-	-	-	910810	2-4-5441	5-73-220(4)
2-40-1701	16-30-102	2-28-2867X	5-278X**	2-26-497	-	-	211545X	-	915627	-	-
2-40-2461	20-30-22	2-28-2137X	5-213X**	2-26-527	211179X	-	-	-	910811	2-4-5441	5-73-220(4)
2-40-2481	20-30-12	2-28-2407X	5-443X**	2-26-457	211342X	-	-	-	912442	2-4-5891	4-73-120
2-40-2301	20-30-12	2-28-2407X	5-315X**	2-26-457	-	-	211489X	-	913797	2-4-5891	4-73-120
2-40-1711	20-30-22	2-28-2137X	5-213X**	2-26-527	211179X	-	-	-	910811	2-4-5441	5-73-220(4)
-	-	2-28-2407X	5-315X**	2-26-457	-	-	211489X	-	913797	-	-
2-40-2481	20-30-12	2-28-2407X	5-443X**	2-26-457	211342X	-	-	-	912442	2-4-5891	4-73-120
2-40-2301	20-30-12	2-28-2407X	5-443X**	2-26-457	-	-	211489X	-	913797	-	-
2-40-2481	20-30-12	2-28-2407X	5-443X**	2-26-457	-	-	211489X	-	913797	-	-
2-40-2301	20-30-12	2-28-2407X	5-315X**	2-26-457	-	-	211489X	-	913797	-	-
2-40-2451	16-30-62	2-28-2717X	5-443X**	2-26-457	211342X	-	-	-	914982	-	-
2-40-2361	16-30-102	2-28-2867X	5-278X**	2-26-497	211544X	-	-	-	917279	-	-
2-40-2381	16-30-102	2-28-2867X	5-278X**	2-26-497	211544X	-	-	-	917279	-	-
2-40-2481	20-30-12	2-28-3087X	5-278X**	2-26-477	-	-	211543X	-	915632	-	-
2-40-1771	10-32-92	2-28-2807X	5-278X**	2-26-497	211544X	-	-	-	918729	-	-
2-40-2241	14-30-62	2-28-2827X	5-278X**	2-26-497	211544X	-	-	-	918329	-	-
2-40-2461	20-30-22	2-28-3067X	5-213X**	2-26-527	-	-	211631X	-	918585	-	-
2-40-2481	20-30-12	2-28-3087X	5-278X**	2-26-477	-	-	211543X	-	918528	-	-
2-40-2241	14-30-62	2-28-2827X	5-278X**	2-26-497	211544X	-	-	-	918329	-	-
2-40-2441	16-30-102	2-28-2867X	5-278X**	2-26-497	211544X	-	-	-	918523	-	-
2-40-1701	16-30-62	2-28-2867X	5-278X**	2-26-497	-	-	211545X	-	915627	-	-
-	24-30-42	2-28-3447X	5-618X**	2-26-527	211996X	2-3-12161X	-	-	919510	-	5-73-1228(4)
2-40-2461	20-30-22	2-28-2887X	5-625X**	2-26-477	-	-	211543X	-	919279	-	-
2-40-2441	16-30-102	2-28-2867X	5-625X**	2-26-497	211544X	-	-	-	918523	-	-
2-40-2461	20-30-22	2-28-2887X	5-625X**	2-26-477	-	-	211543X	-	919279	-	-
2-40-2661	16-30-102	2-28-2867X	5-625X**	2-26-497	211544X	-	-	-	918523	-	-
2-40-2671	20-30-12	2-28-3087X	5-625X**	2-26-497	211544X	-	-	-	920151	-	-
2-40-2681	14-30-62	2-28-2827X	5-625X**	2-26-497	211544X	-	-	-	919898	-	-
-	24-30-42	3-28-1327X	5-627X**	3-26-757	212019X	3-3-4531X	-	-	919754	-	5-73-1228(4)
-	-	2-28-2827X	5-625X**	2-26-497	211544X	-	-	-	918329	-	-
2-40-2361	16-30-102	2-28-2867X	5-625X**	2-26-497	211544X	-	-	-	918523	-	-
-	24-30-42	2-28-3447X	5-618X**	2-26-527	211996X	2-3-12961X	-	-	918571	-	-
-	24-30-42	3-28-1327X	5-627X**	3-26-757	212019X	3-3-5861X	-	-	920546	-	-
2-40-2441	14-30-62	2-28-2827X	5-625X**	2-26-477	-	-	211969X	-	920476	-	-
3-40-2091	28-30-62	3-28-1527X	5-627X**	3-26-757	-	-	212025X	-	921054	-	-
2-40-2801	20-30-22	2-28-3857X	5-736X**	2-26-457	-	-	212085X	-	920808	-	-
3-40-2111	28-30-62	3-28-1527X	5-627X**	3-26-757	-	-	212025X	-	921054	-	-
2-40-2791	20-30-52	2-28-3277X	SPL25-1X**	2-26-527	-	-	211913X	-	922091	-	-
2-40-2791	20-30-52	2-28-3277X	SPL25-1X**	2-26-527	-	-	211913X	-	922091	-	-
-	14-30-62	-	-	-	-	-	-	032SG80002	-	-	211982X (3)

Numbers 1-15 by components refer to corresponding numbers on assembly drawings on pages 24-27.

■ Refer to Application section for appropriate tube length.

UNWELDED ASSEMBLY COMPONENT DRAWINGS

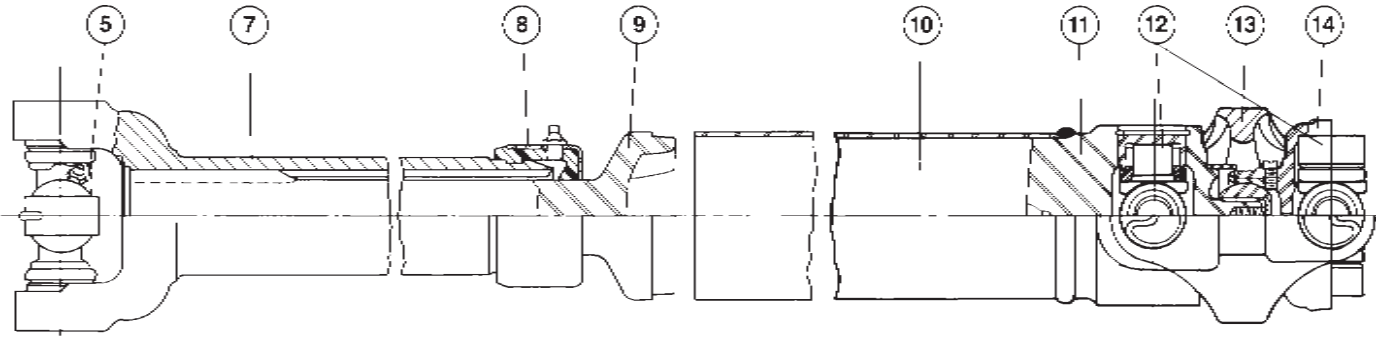

Fig. M

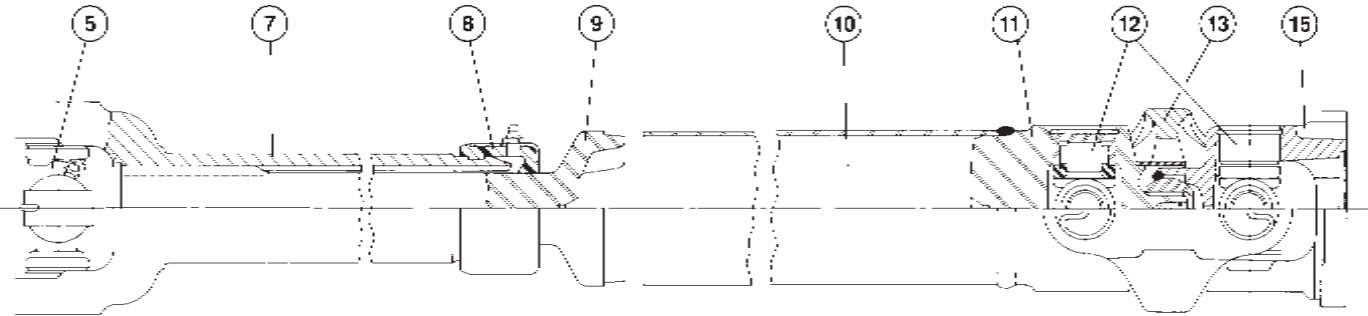

Fig. N

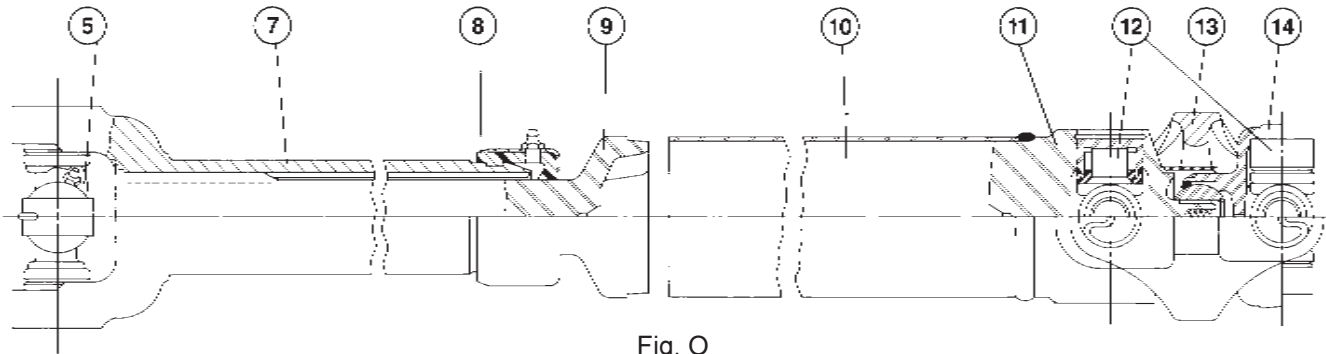

Fig. O

BILLS OF MATERIAL

Part Number	Series	Fig.	1 Flange Yoke	2 Flanged Socket Yoke (Centering Kit)	3 Socket Yoke (Centering Kit)	4 Center Yoke	4A Tube Yoke	5 U-Joint	6 Ball Stud Socket Yoke Assembly	7 Slip Yoke Assembly	8 Dust Cap Kit or Boot Kit Ass'y.
909363	1310	M	—	—	—	—	—	5-153X	—	2-3-8021KX	211121X
909364	1310	M	—	—	—	—	—	5-153X	—	2-3-8841KX	211256X
909365	1310	M	—	—	—	—	—	5-153X	—	2-3-8001KX	211121X
● 911818	1330	O	—	—	—	—	—	5-1204X	—	2-3-8041KX	211121X
913971	1310	N	—	—	—	—	—	5-153X	—	2-3-8001KX	211121X
● 916870	1310	N	—	—	—	—	—	5-1306X	—	2-3-10621KX	211121X
● 919976	1210	P	2-2-1049	—	—	—	—	5-443X	—	2-3-8961KX	211256X
● 919990	1210	Q	2-2-1049	—	—	—	—	5-443X	—	2-3-8961KX	211256X

Numbers 1-15 by components refer to corresponding numbers on assembly drawings on pages 30-31.

● Indicates driveshaft assemblies with non-greasable socket yoke assemblies.

UNWELDED ASSEMBLY COMPONENT DRAWINGS

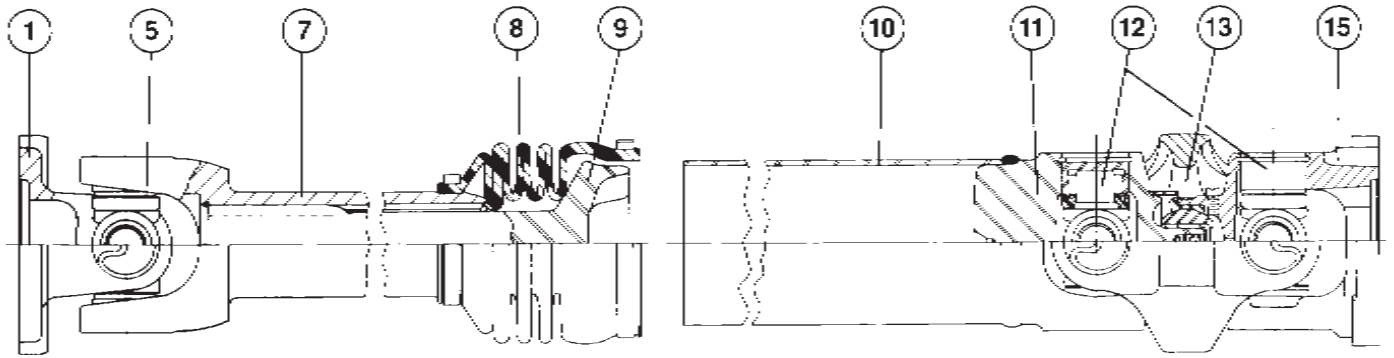

Fig. P

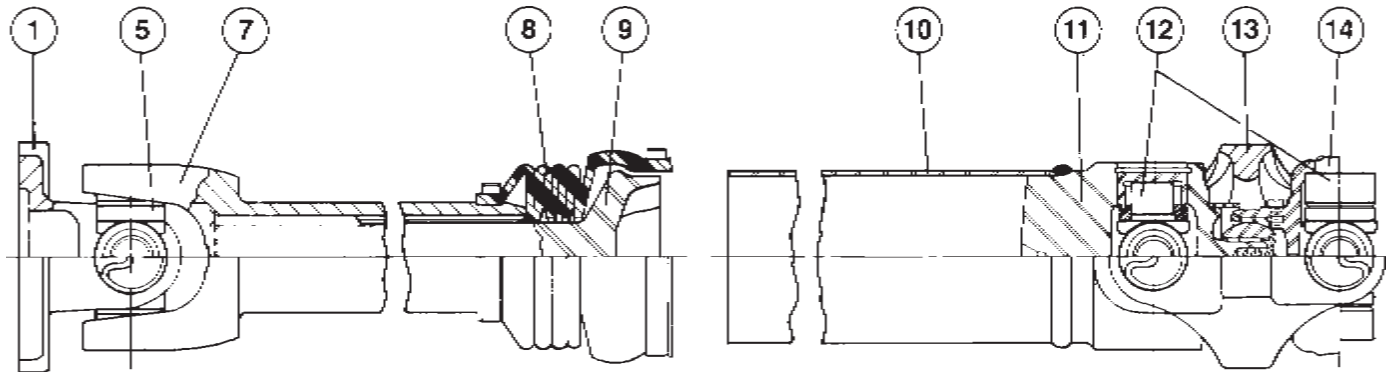

Fig. Q

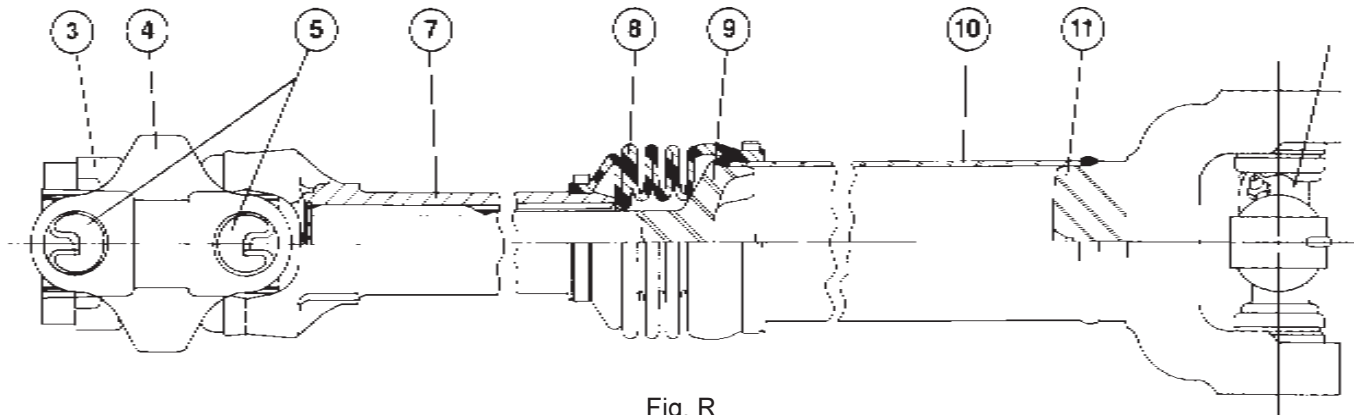

Fig. R

9 Tube Shaft	10 Tubing ♦	11 Ball Stud Tube Yoke	12 U-Joint Kits 2 Req'd	13 Center Yoke	14 Socket Yoke (Centering kit)	14A Slip Yoke Assembly	15 Flanged Socket Yoke	CV Head Assy.	End Yoke	Bolts
2-40-1851	20-30-22	2-28-2887X	5-278X	2-26-497	211544X	—	—	915621	—	—
2-40-1771	10-32-92	2-28-2807X	5-278X	2-26-497	211544X	—	—	915628	—	—
2-40-1701	16-30-102	2-28-2867X	5-278X	2-26-497	211544X	—	—	915629	—	—
2-40-1851	20-30-22	2-28-2137X	5-213X	2-26-527	211996X	—	—	918623	—	—
2-40-1701	16-30-102	2-28-2867X	5-278X	2-26-497	—	—	211452X	915627	—	—
2-40-1701	16-30-102	2-28-2867X	5-278X	2-26-497	—	—	211545X	915627	—	—
2-40-2301	20-30-12	2-28-2407X	5-443X	2-26-457	—	—	211489X	913797	—	—
2-40-2301	20-30-12	2-28-2407X	5-443X	2-26-457	211342X	—	—	912442	—	—

Numbers 1-15 by components refer to corresponding numbers on assembly drawings on pages 30-31.

♦ - Refer to Application section for appropriate tube length.

BALANCING SPECIFICATIONS

A driveshaft will not run smooth and vibration-free unless it is straight and in balance. When rebuilding or fabricating any Spicer driveshaft in this catalog, the runout and balancing specifications illustrated must be considered the minimum requirements for satisfactory performance. A driveshaft which does not meet these minimum requirements may wear out and/or fail prematurely.

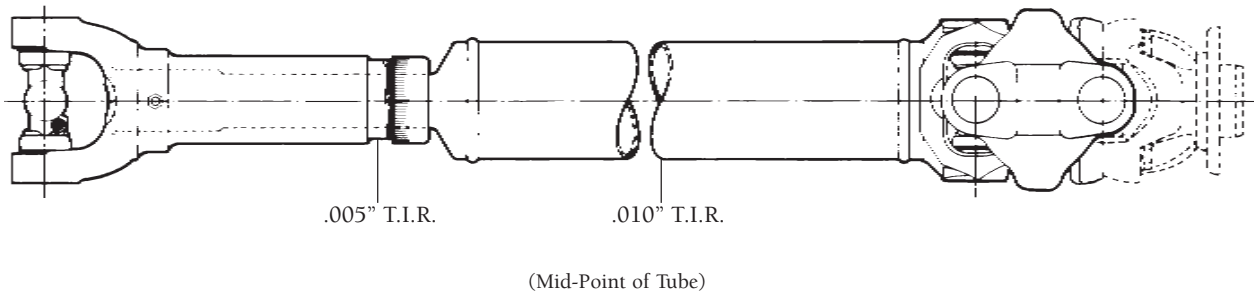

Straightening Requirements After Welding

Balancing Equipment and Operation

Driveshafts should be assembled, straightened, and dynamically balanced by properly trained operators only upon commercially manufactured equipment specifically designed for this purpose. The following procedures and specifications are the minimum acceptable. Be sure to follow all of the instructions provided by the manufacturer of the equipment you are using.

1. After assembly and **before** welding, pre-straighten driveshafts to .005" T.I.R. next to each weld location to help prevent excessive bending of tubes when straightening after welding.
2. After welding, straighten shaft to the T.I.R. readings shown above.
3. Dynamically balance the entire shaft at the speed representative of the speed shaft will encounter in its normal application, unless the driveshaft fabrication equipment manufacturer recommends otherwise.
4. Balance driveshaft to within one ounce-inch for each ten (10) pounds of weight, divided proportionally at each end of the shaft. The weight of the shaft should be based on the total assembly, less flange yokes and end yokes.

Additional information on driveshaft service is available in our driveshaft service manual (publication no. 3264-2).

 **CAUTION:** A driveshaft rotating at speeds of 500 RPM or greater must be dynamically balanced. Failure to properly dynamically balance a driveshaft could cause serious personal injury or death.

SPICER®



Commercial Vehicle Service Parts
Dana Corporation
P.O. Box 321
Toledo, OH 43697
Phone:419-866-3900
Fax:419-866-3925

www.dana.com
www2.dana.com/expert

©Dana Corporation, 2001